



USER MANUAL

RSA 2625-TB



For Serial Numbers:
TM154 XX X XXX



Table of Contents

Chapter	Title	Page
1	GENERAL INFORMATION	1-1
1.1	Revision Control	1-1
1.2	Technical Support	1-1
1.3	Replacement Parts	1-1
1.4	Field Service Assistance	1-2
1.5	Warranty	1-2
1.6	Description of RSA 2625-TB Random Semi-Automatic Case Sealer	1-4
2	IMPORTANT SAFEGUARDS	2-1
2.1	Safety Label Descriptions	2-1
2.2	Explanation of Signal Word Consequences	2-4
2.3	Operator Skill Level Descriptions	2-5
2.3.1	Skill “A” Machine Operator	2-5
2.3.2	Skill “B” Mechanical Maintenance Technician	2-5
2.3.3	Skill “C” Electrical Maintenance Technician	2-5
2.3.4	Skill “D” Manufacturer’s Technician	2-5
3	SPECIFICATIONS	3-1
3.1	Machine Dimensions	3-1
3.2	Machine Operating Conditions	3-2
3.2.1	Power Requirements	3-2
3.2.2	Operating Speed	3-2
3.2.3	Tape Specifications	3-2
3.2.4	Case Specifications	3-2
4	SET-UP PROCEDURES	4-1
4.1	Receiving and Handling	4-1
4.2	Table Leveling	4-2
4.3	Installation of External In-Feed and Exit Conveyors	4-3
4.4	Control Box	4-3
4.5	Connecting Utilities	4-4
4.5.1	Electrical Utilities	4-4
4.5.2	Air Connection	4-5
4.5.3	Pneumatic Adjustment	4-5
4.6	Tape Loading	4-6
4.7	Tape Threading Preparation	4-7
4.8	Tape Threading	4-8

Chapter	Title	Page
4.8.1	Upper Tape Head.....	4-8
4.8.2	Lower Tape Head.....	4-8
5	OPERATING INSTRUCTIONS	5-1
5.1	Operating Procedures	5-1
6	TROUBLESHOOTING	6-1
7	<u>ILLUSTRATED PARTS LIST</u>	7-1

List of Figures

Figure	Name	Page
Figure 1-1	RSA 2625-TB Random Semi-Automatic Case Sealer	1-4
Figure 3-1	Machine Dimensions	3-1
Figure 4-1	Receiving and Handling.....	4-1
Figure 4-2	Table Leveling	4-2
Figure 4-3	Control Box.....	4-3
Figure 4-4	Electrical Utilities.....	4-4
Figure 4-5	Air Regulator.....	4-5
Figure 4-6	Tape Loading.....	4-6
Figure 4-7	Tape Threading Preparation.....	4-7

List of Tables

Table	Name	Page
Table 1-1	Replacement Parts	1-1
Table 2-1	Operators Skill Level.....	2-5
Table 3-1	Case Sizes.....	3-3

Chapter 1 **GENERAL INFORMATION**

1.1 REVISION CONTROL

REV00..... Initial Release

1.2 TECHNICAL SUPPORT

This is the Interpack Model RSA 2625-TB Random Semi-Automatic Case Sealer you ordered. It has been setup and tested in our factory with Intertape manufactured pressure sensitive tapes. If any problems occur when setting up or operating this equipment, please contact the authorized distributor from where you purchased this item.

If contact with the authorized distributor is not possible, Interpack Technical Support is available. Should the need to contact Interpack Technical Support arise, please have the Case Sealer model number and serial number on hand. This information can be found on the nameplate of the side panel of the machine. Interpack Technical Support is available during normal business hours (Eastern Time).

- **PHONE: 813 621-8410 x101**

If you have a technical question that does not require an immediate response, you may contact Interpack by fax.

- **FAX: 813-621-8449**

Technical support may also be contacted via email at the address below:

- **EMAIL: Machsupp@itape.com**

1.3 REPLACEMENT PARTS

This Machine Is Designed to Provide Years of Trouble-Free Operation. However, Maintaining A Small Inventory of Spare Parts Assures Minimum Downtime in The Event of A Problem. We Recommend That You Stock the Following Spare Parts.

DESCRIPTION	ITEM NUMBER	RECOMMENDED QUANTITY
Bearing Pulley	UPM0324	2
Belt, DRV SAG12E, 2" X 6ft. 7.50"	TBD	2
Linear Bearing 25mm Shaft	LM25UU	2
Spring Blade	UPM0011	2
BO Pressure Gauge 40mm 0.6 Bar	UPM3273	1
Wheel 2-7/8"DIA. Compr. Guide	UPM1659	2

Table 1-1 Replacement Parts

Replacement Parts

Order parts by item number, part description, and quantity required. Replacement parts are available from your authorized Interpack distributor exclusively.

Should you require assistance selecting the correct part, you may call:

Intertape Polymer Group
Interpack Machinery
9940 Currie Davis Drive, Suite 23B
Tampa, FL, 33619

Tel: 1-800-474-8273, Option 3

Fax: 1-800-462-1293

MODEL: _____

SERIAL NUMBER: _____

DISTRIBUTOR PURCHASED FROM: _____

DATE OF PURCHASE: _____

1.4 FIELD SERVICE ASSISTANCE

This machine is designed to provide years of trouble-free operation. If any problems arise with this machine during the normal course of operation, your properly trained and qualified internal service personnel should be able to repair any issues after consulting Chapter 6, [Troubleshooting](#).

Service support is available from your authorized Interpack distributor at additional cost if the problem cannot be remedied after consulting the Troubleshooting chapter of this manual.

1.5 WARRANTY

EQUIPMENT WARRANTY AND LIMITED REMEDY: The following warranty is made in lieu of all other warranties, express or implied, including but not limited to the implied warranty of merchantability, the implied warranty of fitness for a particular purpose, and any implied warranty arising out of a course of dealing, a custom or usage of trade:

Intertape sells its Interpack Tape Heads, Case Tapers, and Case Erectors with the following warranties:

1. The ETX Tape Heads' knife blades, springs and wipe down rollers will be free from all defects for a period of ninety (90) days.
2. All other ETX Tape Head parts will be free from all defects for one (1) year after delivery.
3. Water Activated Tape Head blades will be free from defects for ninety (90) days after delivery.
4. Drive Belts will be free from defects for ninety (90) days after delivery.
5. The Gear Motors will be free from defects for one (1) year after delivery.
6. All other components for Case Tapers and Case Erectors will be free from defects for one (1) year after delivery.

If any part is proven defective within its warranty period, then the exclusive remedy and Intertape's and the seller's sole obligation shall be, at Intertape's option, to repair or replace the part, provided the defective part is returned immediately to Intertape's factory or an authorized service station designated by Intertape.

A part will be presumed to have become defective after its warranty period unless the part is received or Intertape is notified of the problem no later than five (5) calendar days after the warranty period.

If Intertape is unable to repair or replace the part within a reasonable time, then Intertape, at its option, will replace the equipment or refund the purchase price. Intertape shall have no obligation to install the repaired or replacement part.

Intertape shall have no obligation to provide or pay for the labor required to install the repaired or replacement part. Intertape shall have no obligation to repair or replace (1) those parts failing due to: operator misuse, carelessness, or due to any accidental cause other than equipment failure, or (2) parts.

1. Failure or damage is due to misapplication, lack of proper maintenance, abuse, improper installation or abnormal conditions such as temperature, moisture, dirt or corrosive matter, etc.
2. Failure due to inadequate cleaning, improper operating environment, improper utilities or operator error.
3. Failure due to operations above the rated capacities, or in any other improper manner, either intentional or otherwise.
4. Failure is due to equipment, which has been altered by anyone other than an authorized representative of Intertape Polymer Group.
5. Failure is due to an attempt by the purchaser to correct alleged defective equipment. In this event the purchaser is responsible for all expenses incurred.

LIMITATION OF LIABILITY: Intertape and seller shall not be liable for direct, indirect, special, incidental or consequential damages based upon breach of warranty, breach of contract, negligence, strict liability or any other legal theory.

The foregoing Equipment Warranty and Limited Remedy and Limitation of Liability may be changed only by written agreement signed by authorized officers of Intertape and seller.

1.6 DESCRIPTION OF RSA 2625-TB RANDOM SEMI-AUTOMATIC CASE SEALER

This machine is designed to provide years of trouble-free operation. If any problems arise with this machine during the normal course of operation, your properly trained and qualified internal service personnel should be able to repair any issues after consulting the [Troubleshooting](#) section of this manual.



Figure 1-1 RSA 2625-TB Random Semi-Automatic Case Sealer

The Interpack RSA 2625-TB Random Semi-Automatic Case Sealer Machine with ETX Tape Heads is designed to apply Intertape brand pressure sensitive case sealing tape to the top and bottom center seam of regular slotted corrugated cases. The RSA 2625-TB Random Semi-Automatic Case Sealer is manually adjustable to a wide range of case sizes (refer to Case Specifications, [page 3-2](#)). Multi-Wheel Top Squeezers compress the top major flaps ensuring superior seal. The RSA 2625-TB Random Semi-Automatic Case Sealer features reversible operator controls to facilitate its adaptation into an existing conveyor line.

Chapter 2 **IMPORTANT SAFEGUARDS**

2.1 SAFETY LABEL DESCRIPTIONS

There Are a Number Of Safety Labels Used On Intertape Case Sealers.

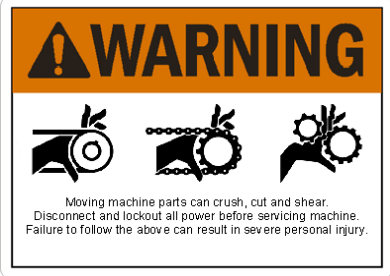
<p>The illustrated label, as shown, is attached to the Knife Guard inside the upper and lower ETX Tape Head. The label warns operators and service personnel of the very sharp knife used to cut the tape at the end of the tape application.</p> <p>The ETX Tape Heads are equipped with a Knife guard that covers the blade. The Tape Heads should never be operated with the blade guards removed.</p> <p>Turn air and electrical supplies off before servicing the tape heads.</p>	 <p>The image shows a rectangular safety label with a white background and a black border. At the top, there is an orange horizontal bar containing a black exclamation mark inside a triangle and the word "WARNING" in bold black capital letters. Below this bar, the text "Sharp Cutting Blade" is centered in a large, black, sans-serif font.</p>
<p>The label shown is affixed on the in-feed and exit ends of the machine belt drives. The label warns the operators and service personnel of the pinch points at each end of the belt drives.</p>	 <p>The image shows a rectangular safety label with a white background and a black border. At the top, there is an orange horizontal bar containing a black exclamation mark inside a triangle and the word "WARNING" in bold black capital letters. Below this bar, there are three black icons: a hand being crushed by a wheel, a hand being cut by a gear, and a hand being sheared by a gear. Below the icons, there is a small block of text: "Moving machine parts can crush, cut and shear. Disconnect and lockout all power before servicing machine. Failure to follow the above can result in severe personal injury."</p>

The label shown is attached to the control box. The label warns the service personnel to unplug the power supply before attempting any service work on the case sealer.

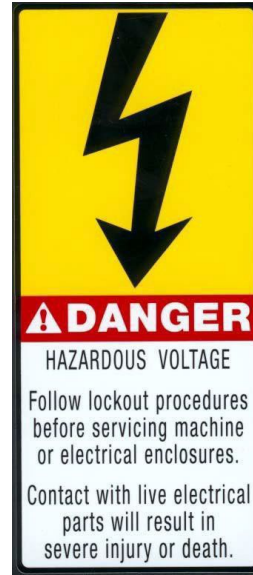

The label shown is affixed on the “EXIT” end of the Left Hand side cover. The label warns the operators and service personnel of the pinch point at the exit ends of the machine.





The label shown is affixed on the side of the column. This label provides convenient safety instruction for the operator and service personnel in the operation of the Interpack Case Sealing Equipment.

⚠ WARNING	
OPERATION / SERVICE <ul style="list-style-type: none"> • Only trained people are to operate and service machine. • Shut off power to machine before adjusting. • Unplug electrical power before servicing. 	
MACHINE MANUAL For other important safety, operating and service information read this machine's manual.	
EYE HAZARD Wear Safety Glasses which conform to ANSI Std. Z87.1 or EN 166	
COVERS AND GUARDS All covers and guards must be in place before operating machine.	
ELECTRICAL SHOCK Hazardous voltages may cause personal injury. Only authorized and qualified personnel are to service electrical enclosures.	
FAILURE TO FOLLOW THE ABOVE COULD RESULT IN SEVERE INJURY.	

Note: Should any of the safety labels placed on the Case Sealer be damaged or destroyed, replacements are available through your distributor.

2.2 EXPLANATION OF SIGNAL WORD CONSEQUENCES

 **WARNING:** Indicates a potentially hazardous situation that, if not avoided, could result in death or serious injury or property damage.

 **CAUTION:** Indicates a potentially hazardous situation that, if not avoided, could result in minor or moderate injury or property damage.

WARNING

- **To reduce the risk associated with mechanical, pneumatic, and electrical hazards:**
 - a. Read, understand, and follow all safety and operating instructions before operating or servicing the case sealer.
 - b. Allow only properly trained and qualified personnel to operate and service this equipment.
- **To reduce the risk associated with pinches, entanglement, and hazardous voltage:**

Turn electrical supply off and disconnect before performing any adjustments, maintenance, or servicing of the machine or taping heads.
- **To reduce the risk associated with pinches and entanglement hazards:**
 - a. Do not leave the machine running while unattended.
 - b. Turn the machine off when not in use.
 - c. Never attempt to work on any part of the machine, load tape, or remove jammed boxes from the machine while the machine is running.
- **To reduce the risk associated with hazardous voltage:**

Position electrical cord away from foot and vehicle traffic.
- **To reduce the risk associated with sharp blade hazards:**

Keep hands and fingers away from tape cutoff blades. Blades are extremely sharp.
- **To reduce the risk associated with fire and explosion hazards:**

Do not operate this equipment in potentially flammable/explosive environments.
- **To reduce the risk associated with muscle strain:**
 - a. Use the appropriate rigging and material handling equipment when lifting or repositioning this equipment.
 - b. Use proper body mechanics when removing or installing taping heads that are moderately heavy or may be considered awkward to lift.

CAUTION

- **To reduce the risk associated with pinch hazards:**
 - a. Keep hands clear of the upper head support assembly as boxes are transported through the machine.
 - b. Keep hands, hair, loose clothing, and jewelry away from box compression rollers.
 - c. Always feed boxes into the machine by pushing only from the end of the box.
 - d. Keep hands, hair, loose clothing, and jewelry away from moving belts and taping heads.

2.3 OPERATOR SKILL LEVEL DESCRIPTIONS

Important: The area supervisor must ensure that the operator has been properly trained on all machine functions before operating the machine.

2.3.1 Skill “A” Machine Operator

This operator is trained to use the machine with the machine controls. This operator can feed cases into the machine, make adjustments for different case sizes, change tapes, and start/stop, and re-start production.

2.3.2 Skill “B” Mechanical Maintenance Technician

This technician is trained to use the machine as the machine operator, and is able to work with the safety protection disconnected, check and adjust mechanical components, perform maintenance operations, and repair the machine. He is not allowed to work on live electrical components.

2.3.3 Skill “C” Electrical Maintenance Technician

This technician is trained to use the machine as the machine operator, and is able to work with the safety protection disconnected, check and adjust mechanical components, perform maintenance operations, and repair the machine. He is allowed to work on live electrical panels, terminal blocks, and control equipment.

2.3.4 Skill “D” Manufacturer’s Technician

Skilled technician sent by the manufacturer, or its agent, to perform complex repairs or modifications, when agreed to by the customer.

Operation	Machine Condition	Operator Skill Level	Number of Operators
Machine Installation & Set-Up	Running with Safety Protections Disabled	B & C	2
Adjusting Case Size	Stopped by Pressing the Emergency Stop (E-Stop) Button	A	1
Tape Roll Replacement	Stopped by Pressing the Emergency Stop (E-Stop) Button	A	1
Blade Replacement	Electrical Power Disconnected	B	1
Drive Belt Replacement	Electrical Power Disconnected	B	1
Ordinary Maintenance	Electrical Power Disconnected	B	1
Extraordinary Mechanical Maintenance	Running with Safety Protections Disabled	D	1
Extraordinary Electrical Maintenance	Running with Safety Protections Disabled	C	1

Table 2-1 Operators Skill Level

Notes

Chapter 3 SPECIFICATIONS

3.1 MACHINE DIMENSIONS

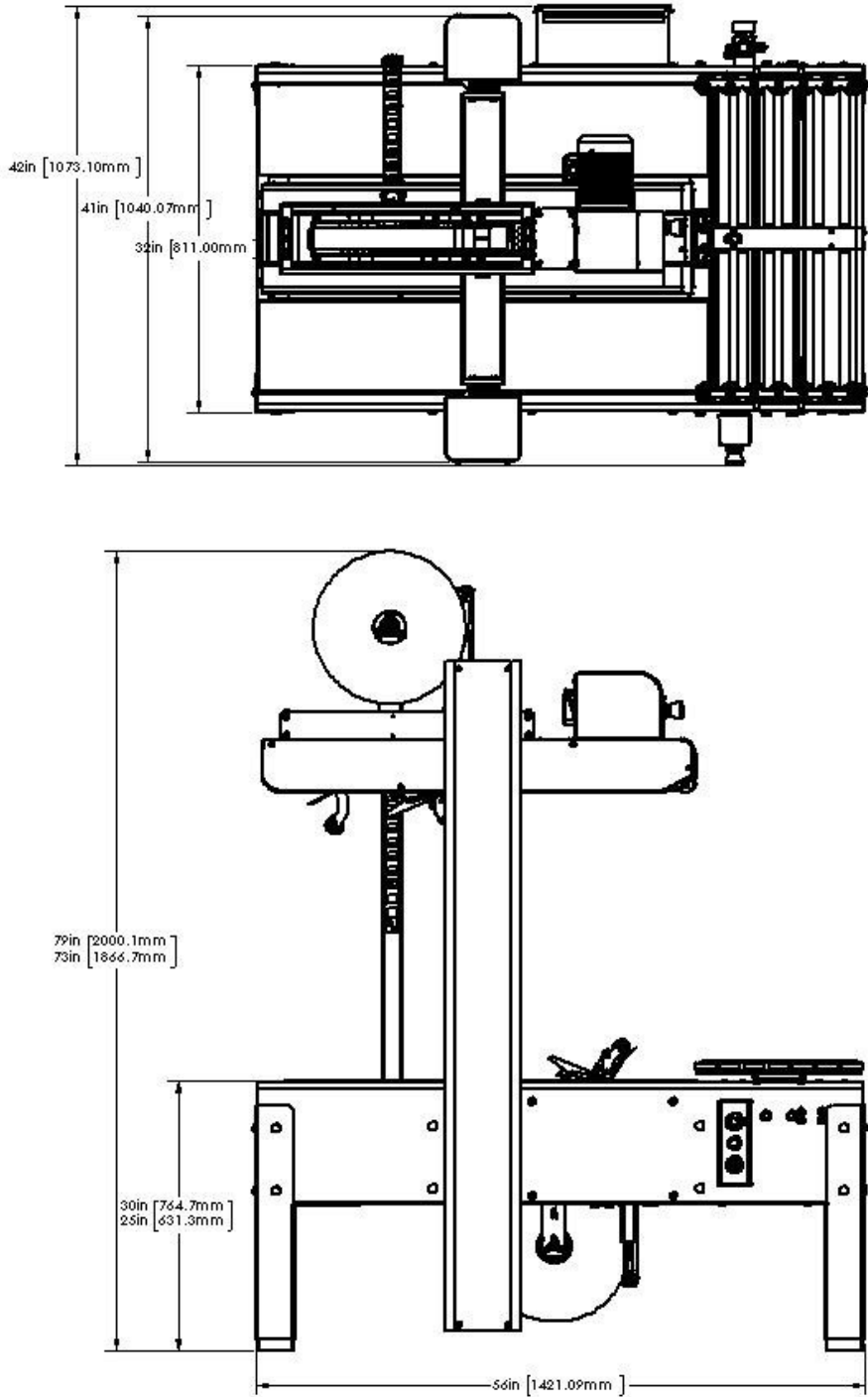

Figure 3-1 Machine Dimensions

3.2 MACHINE OPERATING CONDITIONS

Always operate the machine in a dry, relatively clean environment at 40 to 105 °F (5 to 40 °C) with clean, dry cases. Machine must be set on a level surface or adjusted to operate on a level plane.

Note: Machine should not be washed down or subjected to conditions causing condensation on components.

3.2.1 Power Requirements

- Electrical - 115V, 60HZ, 8.4A (966 Watts)
- Compressed Air – N/A

This machine comes standard with one (1) 1/4 H.P. and one (1) 1/3 H.P. gear motors and comes with a standard neoprene covered power cord and a grounded plug. Contact your Intertape Representative for power requirements not listed above.

3.2.2 Operating Speed

Actual production rate is dependent on operator's efficiency and the case size mix. Belt speed is 82 ft. per minute.

3.2.3 Tape Specifications

Use **IPG Pressure Sensitive Case Sealing Tape**.

A maximum tape roll diameter of 16 in. (406mm) on a 2 in. (50.8mm) diameter core can be installed on the tape head. (Accommodates all Intertape brand film tape machine roll lengths).

The standard Tape Leg Length of 2.5 in. (63.5mm) is factory set. The standard tape leg length may vary up to ¼ in. (6mm) based on tape tension and line speed.

The optional Tape Leg Length of 2 in. (50.8mm) is factory set. The standard tape leg length may vary up to ¼ in. (6mm) based on tape tension and line speed.

The standard tape leg length is adjustable +/- ¼ in. Refer to the tape head manual for adjustment of tape leg length.

Note: for further specifications on ETX Tape Heads, consult the ETX Tape Head manual provided with this machine.

3.2.4 Case Specifications

Type

- Regular Slotted Containers (RSC).
- Other style cases may be processed. Consult factory for details.

Material

125 - 275 PSI Bursting Test, Single or Double Wall B or C Flutes.

Size

The case sealer can accommodate most cases within the size ranges listed below.

Standard Case Size Capacities			
Case Size	Length	Width	Height
Minimum	6 in. (150mm)	6 in. (150mm)	5 in. (127mm)
Maximum	Infinite	26 in. (508mm)	25 in. (609.6mm)
Optional Case Size Capacities			
Case Size	Length	Width	Height
Minimum	6 in. (150mm)	6 in. (150mm)	2 in. (50.8mm)
Maximum	Infinite	26 in. (508mm)	25 in. (533.4mm)
Minimum	8 in. (203.2mm)	8 in. (203.2mm)	2 in. (50.8mm)
Maximum	Infinite	26 in. (558.8mm)	25 in. (533.4mm)

Table 3-1 Case Sizes

Notes

Chapter 4

SET-UP PROCEDURES

4.1 RECEIVING AND HANDLING

The following instructions are presented in **the order recommended** for setting up and installing the RSA 2625-TB Random Semi-Automatic Case Sealer as well as for **learning the operating functions and adjustments**. Following them step by step will result in your thorough understanding of the machine and an installation in your production line that best utilizes the many features built into the case sealer.

1. Lift off cover and sleeve after removing the strapping and staples at bottom.
2. Remove mounting bolts and nuts, which secure the RSA 2625-TB Random Semi-Automatic Case Sealer to the shipping pallet.
3. Lift machine off pallet and install on your packaging line.
4. Remove machine from the pallet to the location of final installation.

Note: After unpacking the Case Sealer, look for any damage that may have occurred during shipping. Should the case sealer be damaged, file a claim with the transport company and notify your authorized Intertape distributor.

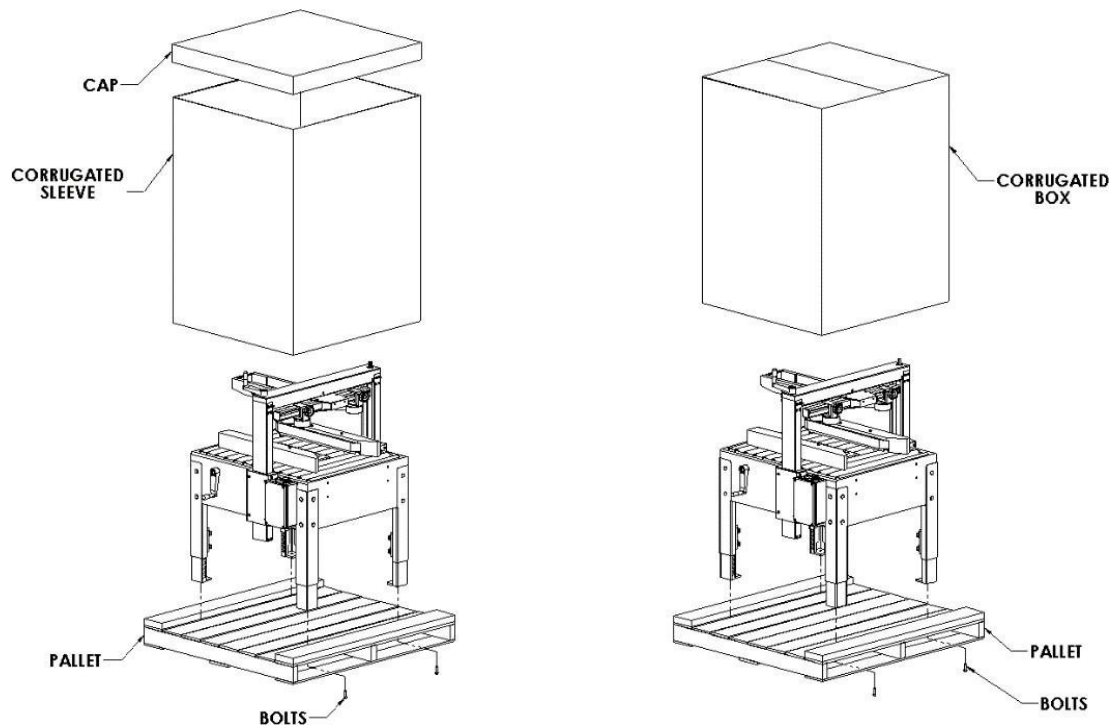

Figure 4-1 Receiving and Handling

4.2 TABLE LEVELING

⚠ WARNING: MACHINE HEIGHT ADJUSTMENT REQUIRES RAISING THE MACHINE TO ADJUST EACH LEG. FOLLOW ALL POSSIBLE SAFETY PROCEDURES PRIOR TO AND DURING THIS PROCESS.

The Case Sealer must be installed on a near level ground.

Ensure that the machine is level and firmly on the ground (no rocking). Adjust the roller height with the four (4) telescopic adjustment legs to accommodate conveyor heights from 24 to 30 inches.

To adjust the Case Sealer height (refer to Figure 4-2):

1. Jack up the machine to give ample room to extend the legs.
2. Using a 3/4" (19 mm) box end wrench, loosen the eight (8) M10 hex head bolts.
3. Adjust the legs to the desired conveyor height and tighten the bolts.

Note: There are etched lines on the legs for ease of leveling.

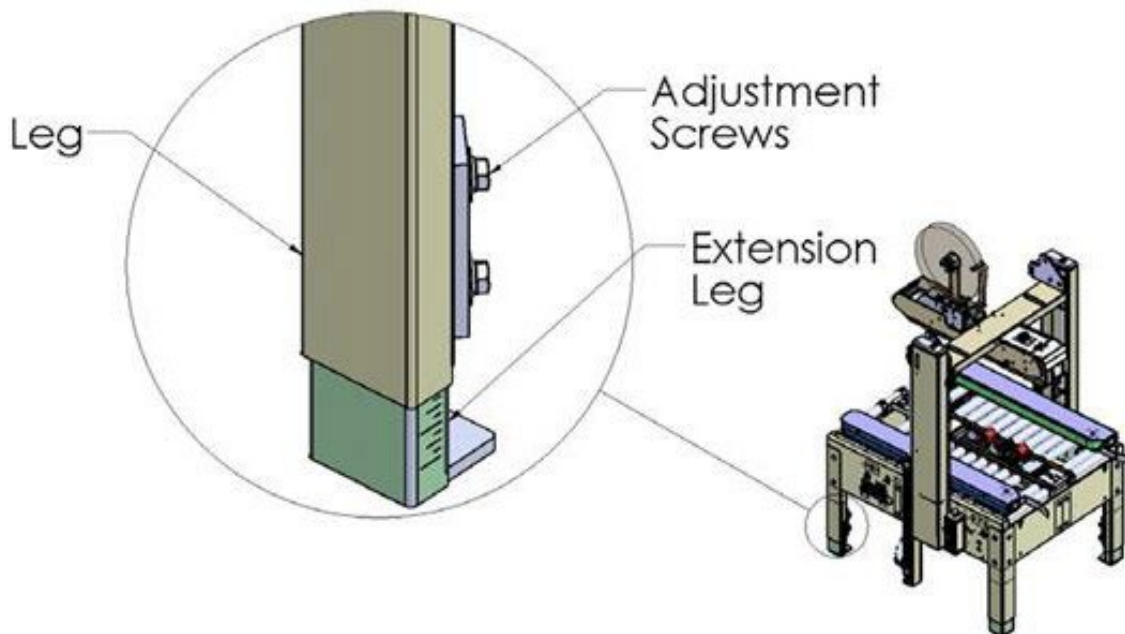

Figure 4-2 Table Leveling

4.3 INSTALLATION OF EXTERNAL IN-FEED AND EXIT CONVEYORS

1. Customer supplied in-feed conveyor (if used) should provide straight and level entry into the case sealer.
2. Customer supplied gravity exit conveyor (if used) should be straight and declined no more than 0.24 in./ft. (20mm/meter) away from the machine to convey the sealed cases away from the machine.
3. Customer supplied powered exit conveyor should be straight and level to convey the sealed cases away from the machine.

4.4 CONTROL BOX

The control box contains the following (refer to Figure 4-3):

1. EMERGENCY STOP button (E-Stop) - The E-Stop is a detent type, when it is pushed down, it will stay in the down position. In order to re-start the machine, the operator has to pull up the E-Stop button and press on the green START push button.
2. START push button - Starts machine operation.
3. BLOCKED selector switch.

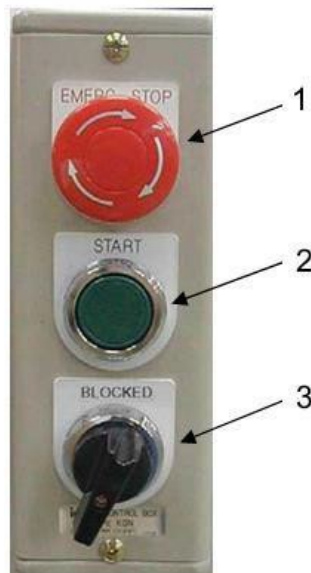

Figure 4-3 Control Box

4.5 CONNECTING UTILITIES

4.5.1 Electrical Utilities

A 12 foot (3.7m) standard three conductor power cord with plug is provided for 115V, 60Hz, 15A electrical service. The servicing receptacle must be properly grounded. Before the machine is plugged into the receptacle, ensure that all materials are removed from the machine.

Note: Use of an extension cord is not recommended because of voltage drop.

The electrical control is protected with an automatic circuit breaker with re-settable overload. This reset is located in the electrical box in the lower left quadrant. Push on the blue button to reset (refer to Figure 4-4).

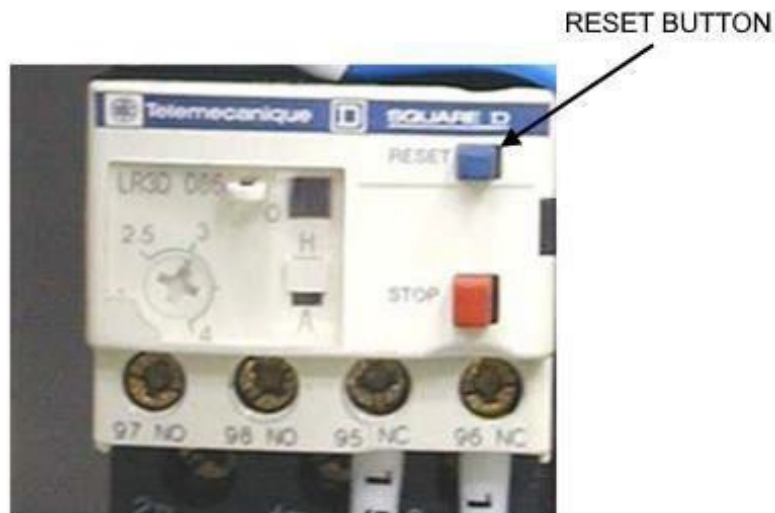

Figure 4-4 Electrical Utilities

4.5.2 Air Connection

The regulator has a male "quick disconnect" adaptor. Connect clean dry compressed air to this adaptor. The RSA2625-TB Random Semi-Automatic Case Sealer requires a minimum of 3 C.F.M. at **75 PSI** maximum.

To regulate the air pressure, pull on the green knob located on the side of the machine. Turn the knob clockwise for more pressure and counterclockwise for less. When the air pressure is at **75 PSI**, push back down on the button until a "click" is felt. The threading size is 3/8 NPT (refer to Figure 4-5).



Figure 4-5 Air Regulator

4.5.3 Pneumatic Adjustment

The main air filter/regulator controls the air pressure going inside the machine. It also controls the air pressure inside the cylinders that raise the Top Belt Drive Assembly and open the infeed guides. **The recommended pressure setting for the main air filter/regulator is between 60 and 70 PSI.**

The Infeed Guide Pressure is controlled with the pressure regulator located at the infeed end of the machine, under the left hand Side Cover. By **increasing** the air pressure, you **increase** the centering force of the guides on the box. **The recommended pressure setting for the Infeed Guide regulator is between 30 and 40 PSI.**

The weight of the Top Belt Drive Assembly on the box is controlled by the High Flow Pressure Control located at the discharge end of the machine, under the left hand Side Cover. This controls the air pressure at the bottom of the cylinder and counterbalance for the weight of the Top Belt Drive Assembly. Therefore, to **reduce** the weight applied on the top of the box, you have to **increase** the air pressure. **The recommended pressure setting for the High Flow Pressure Control is between 35 and 45 PSI.**

4.6 TAPE LOADING

The ETX Tape Heads accommodate 2 in. (50.8mm) wide tape rolls, while the ETX /3 in. Tape Heads accommodate 3 in. (76.2mm) wide rolls.

1. Place the tape head onto a sturdy, flat surface.
2. Move the peel off roller away from the mandrel.
3. Push the roll of tape onto the mandrel with the adhesive side up (refer to Tape Threading [page 4-8](#)) until the core seats against the mandrel flange. This ensures the tape will be aligned when feeding into the tape head.
4. Replace the peel roller against the tape roll.

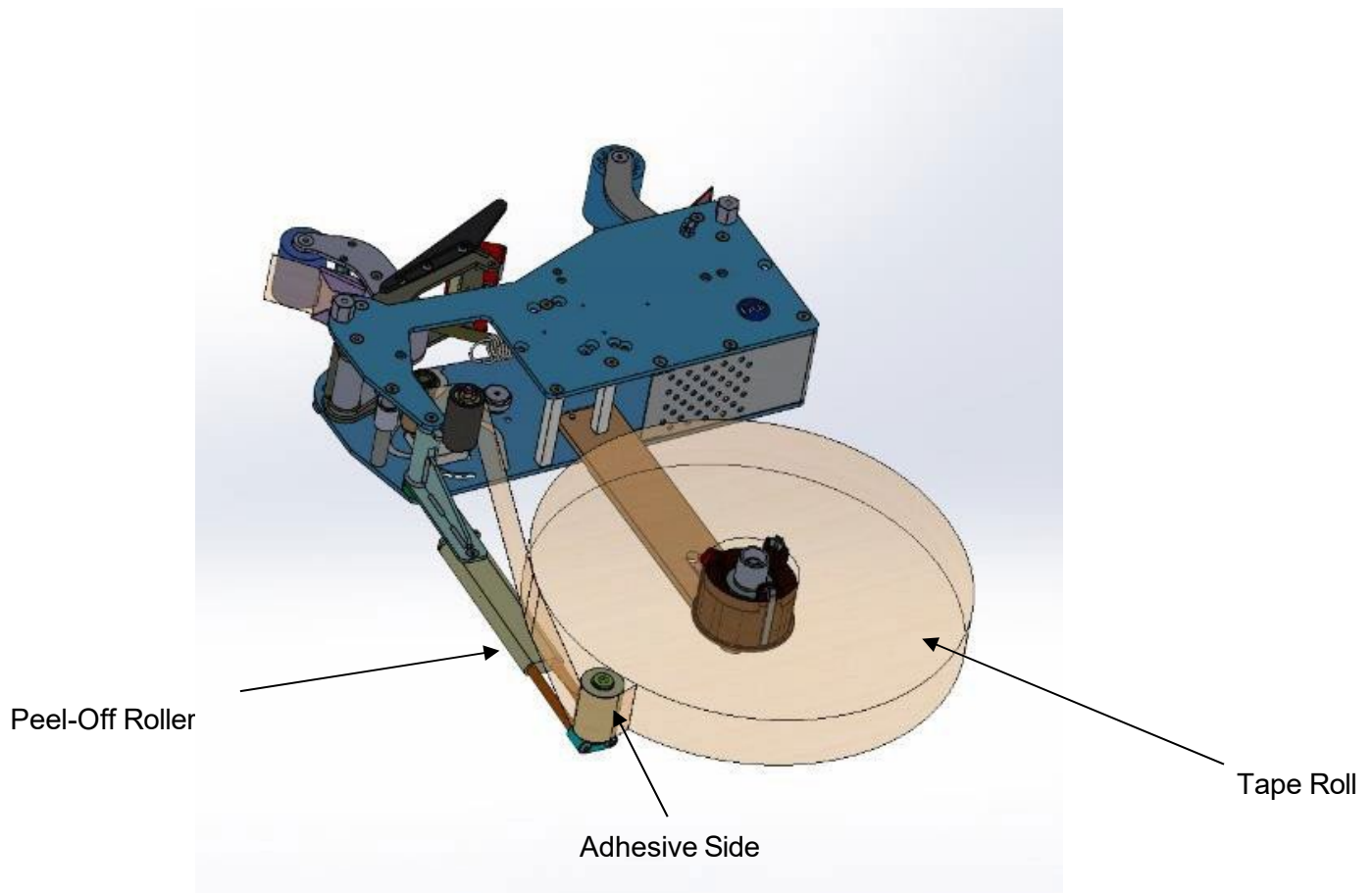

Figure 4-6 Tape Loading

4.7 TAPE THREADING PREPARATION

Threading the tape in the Tape Head does not require any special tools.

Pull approximately 12 in. (304.8mm) of tape from the roll and fold in half lengthwise, adhesive side to adhesive side. This allows you to thread the tape without it adhering to the guide and clutch rollers inside the Tape Head.

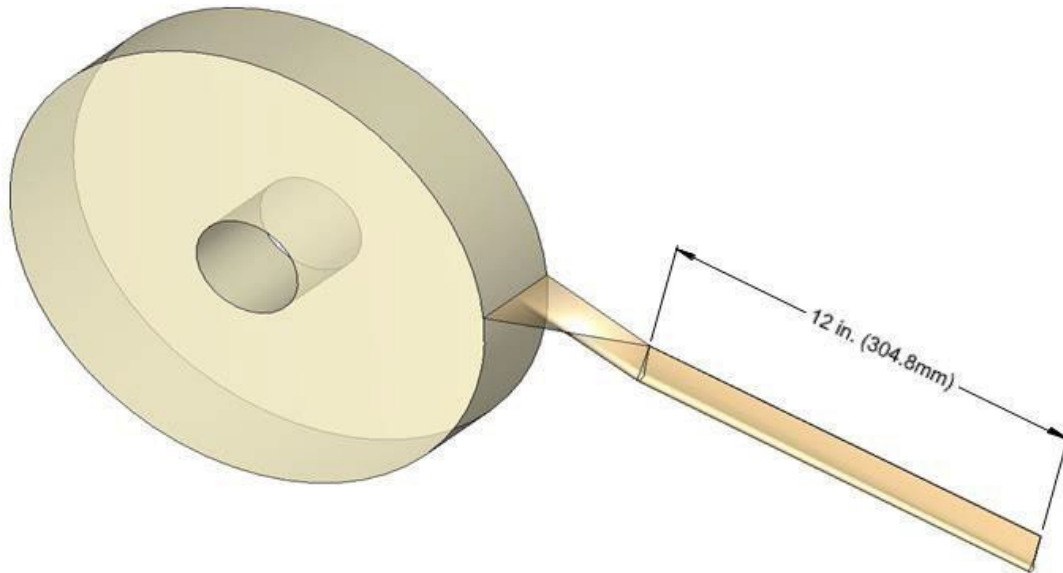

Figure 4-7 Tape Threading Preparation

4.8 TAPE THREADING



WARNING: TURN OFF ELECTRICAL POWER SUPPLY AND DISCONNECT THE POWER CORD FROM THE ELECTRICAL SUPPLY BEFORE BEGINNING TO WORK ON THE TAPE HEADS OR TO LOAD TAPE. IF POWER CORDS ARE NOT DISCONNECTED, SEVERE INJURY TO PERSONNEL COULD RESULT. THE KNIFE CONTAINED IN THE TAPE HEAD IS EXTREMELY SHARP. USE CAUTION WHEN REMOVING THE BLADE GUARD AND THREADING THE TAPE TO AVOID PERSONNEL INJURY.

4.8.1 Upper Tape Head

1. Remove the blade guard from the knife in the Tape head.
2. Follow the Tape Threading Diagram on the side plate of the ETX Tape Head.
3. See your Tape Head manual for further information if required.

4.8.2 Lower Tape Head

1. Lift Top tape Head Box to the uppermost position by activating the “**BLOCKED**” selector switch on the control box.
2. Remove the Lower tape Head by grasping the tape application rollers and lifting straight up.
3. Remove the blade guard from the knife in the Tape head.
4. Follow the Tape threading diagram on the side plate of the ETX Tape Head.
5. See your Tape Head manual for further information if required.
6. Replace the Lower tape head in the machine.
7. Turn off the “**BLOCKED**” selector switch.

Notes

PAGE
INTENTIONALLY
LEFT BLANK

Chapter 5

OPERATING INSTRUCTIONS

5.1 OPERATING PROCEDURES

Once the ETX Tape Heads, (both bottom and top) have been loaded with tape and threaded the machine is ready to process RCS cases. The following instructions are presented in **the order recommended** for processing cases successfully through the RSA 2625-TB Case Sealing machine.

WARNING: ENSURE THAT THE OPERATOR'S HANDS ARE AWAY FROM THE CONTACT AREA BETWEEN THE INFEED GUIDES AND THE CASE.

1. Activate air Supply (3 C.F.M. at 80 PSI).
2. Switch the machine on with START push button.
3. Place case with flaps held in closed position on the Infeed Table up to sensor #1. Sensor will detect case and the Infeed Guides will center the case.
4. Push case with flaps held in closed position against the Front Sensing Paddle at the front of the Top Belt Drive Assembly.
5. This will raise the Top Belt Drive Assembly.
6. Push the rear of the case until it is between the top and bottom drive belts.
7. When the case exits the Case Sealer, the Top Belt Drive Assembly will go down to its initial position.
8. The Case Sealer is now ready to process the next case.

Chapter 6

TROUBLESHOOTING

The RSA 2625-TB Random Semi-Automatic Case Sealer is fabricated with high quality components that provide trouble-free operation for a long period of time. However, should a problem occur, we recommend that you consult the following table. If the problem you encounter is not discussed in this table, call toll-free (877) 447-4832 Interpack [Technical Support](#). Toll-free (877) 447-4832

Trouble	Possible Causes	Solutions
The main power is turned on and nothing happens.	One of the fuses is burned.	Verify all fuses in the electric box.
The machine is ON but the Infeed Guides do not center the case on the Infeed Table.	Compressed air supply is not connected. The air tubing or the valve is obstructed or defective.	Inspect air connection and operating pressure. Inspect the air tubing and the valve for leaks or obstructions.
The Infeed Guides closes when the machine is powered up even when there is no case on the Infeed Table.	The Infeed Table's Sensor is not aligned with his reflector.	Check the alignment of the Infeed Sensor with his reflector.
The Top Belt Drive Assembly stays up or goes down too slowly.	The High Flow Pressure Regulator is adjusted too high.	Reduce the air pressure setting of the High Flow Pressure Regulator, located at the infeed end of the machine, under the left hand Side Cover.
The Top Belt Drive Assembly goes down too quickly or crushes the case.	The High Flow Pressure Regulator is adjusted too low.	Increase the air pressure setting of the High Flow Pressure Regulator, located at the infeed end of the machine, under the left hand Side Cover.
The Top Belt Drive Assembly raises too slowly.	The inlet pressure is too low. The moving parts are rubbing on something.	Adjust the inlet pressure on the main regulator to 80 psi and make sure that the pressure doesn't fall below 70 psi while it is operating. Inspect the Top Belt Drive Assembly to make sure that nothing interferes with them.
The Top Belt Drive Assembly does not rise when the case pushes the Front Sensor Plate.	The Proxy Sensor behind the sensor plate is too far from the Front Sensor Plate.	Remove the Front Sensor Plate and adjust the position of the Proxy Sensor by moving it by 1/16", then replace the Front Sensor Plate and verify proper operation. Make sure that the sensor does not touch the Front Sensor Plate.
The cases are not taped properly.	The tape head is not adjusted correctly.	Refer to the tape head manual.

Chapter 7

ILLUSTRATED PARTS LIST

List of Assemblies

Section	Name	Page
7.1	RSA 2625-TB TOP LEVEL ASSEMBLY	7-3
7.2	USM0882 – BASE ASSEMBLY	7-5
7.2.1	UAM0541 - FRONT ROLLER SET	7-7
7.2.2	UAM0542 - REAR ROLLER SET	7-9
7.2.3	UAM0275 - LEG ASSEMBLY	7-11
7.2.4	UAM0560 - E-STOP CONTROL BOX	7-13
7.3	USM0873 – COLUMN ASSEMBLY	7-15
7.4	USM0879 – TOP BELT ASSEMBLY	7-17
7.4.1	USM0874 – BRIDGE ASSEMBLY	7-21
7.4.2	USM0875 - TOP DRIVE ASSEMBLY LH	7-23
7.4.3	USM0876 - TOP DRIVE ASSEMBLY RH	7-25
7.5	UAM0411 – ELECTRIC CONTROL BOX ASSEMBLY	7-28
7.6	USM0880 – BOTTOM DRIVE ASSEMBLY	7-30
7.6.1	UAM0538 - BOTTOM DRIVE SECTION LH	7-32
7.6.2	UAM0539 - BOTTOM DRIVE SECTION RH	7-34
7.7	USM0878 – CENTERING MECHANISM	7-36
7.8	USM0881– PNEUMATIC CONTROL ASSEMBLY	7-38

PAGE
INTENTIONALLY
LEFT BLANK

7.1 RSA 2625- TB TOP LEVEL ASSEMBLY

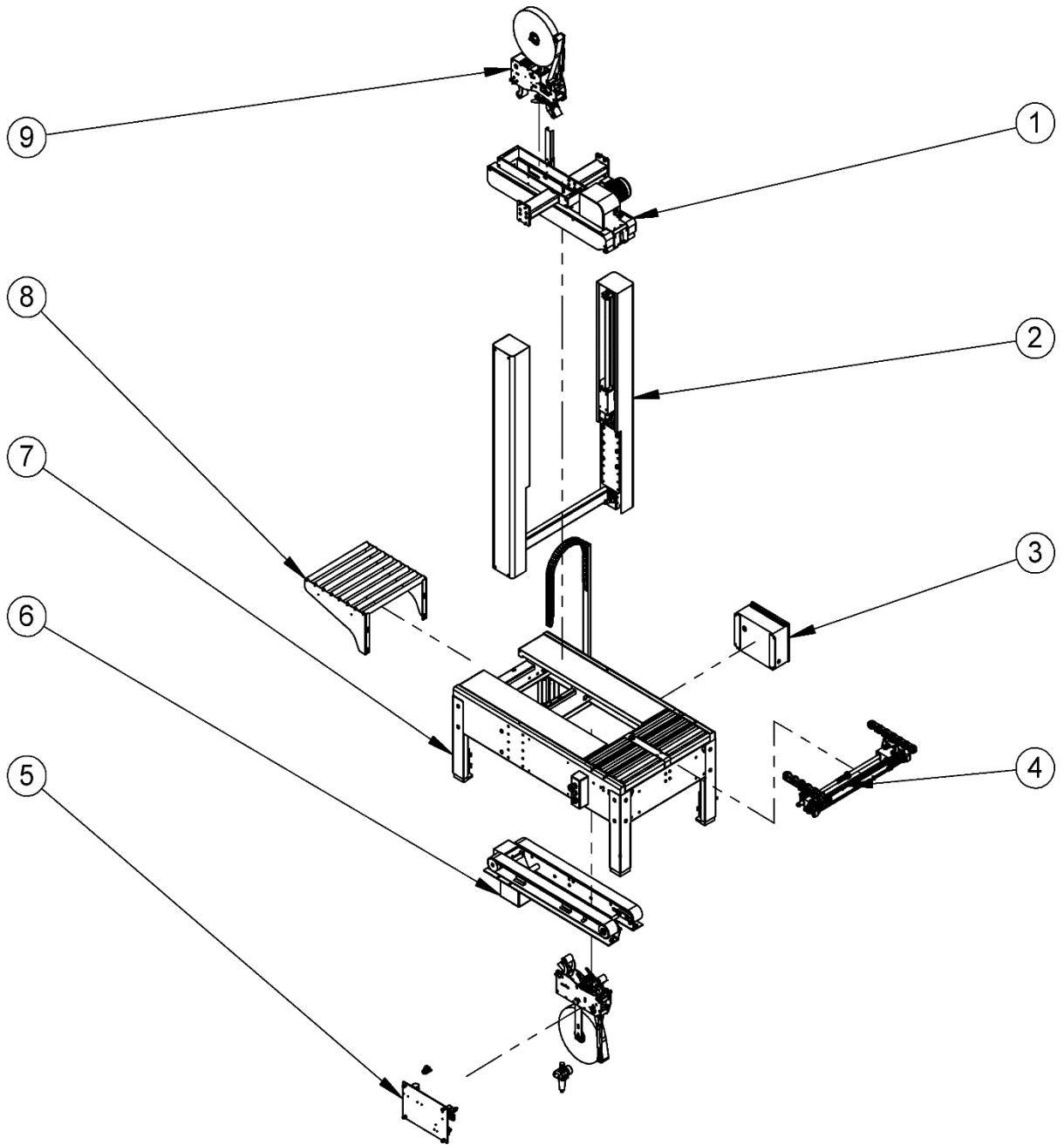

RSA2625 -TOP LEVEL ASSEMBLY

ITEM NO.	PART NUMBER	DESCRIPTION	QTY.
1	USM0879	TOP BELT ASSEMBLY	1
2	USM0873	COLUMN ASSEMBLY	1
3	UAM0411	ELECTRIC CONTROL BOX ASSEMBLY	1
4	USM0878	CENTERING MECHANISM	1
5	USM0881	PNEUMATIC CONTROL ASSEMBLY	1
6	USM0882	BASE ASSEMBLY	1
7	USM0880	BOTTOM DRIVE ASSEMBLY	1

7.2 USM0882 – BASE ASSEMBLY

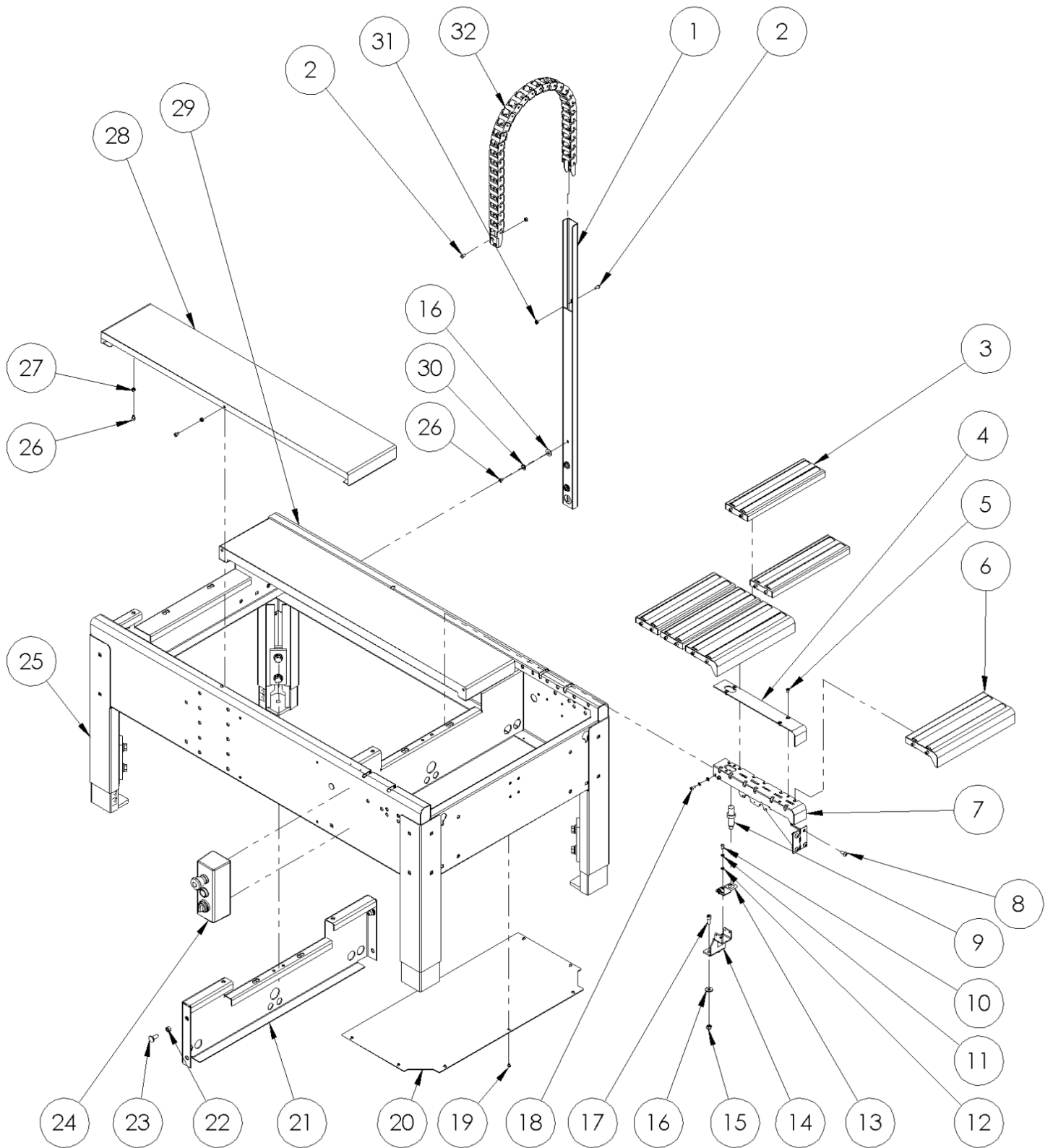

USM0882 – BASE ASSEMBLY

ITEM NO	Part#	DESCRIPTION	QTY
1	UPM6471	CABLE RAIL BRACKET	1
2	UF1216	BHCS M6-1.0-12mm	4
3	UAM0542	REAR ROLLER SET	4
4	UPM6474	CENTER SUPPORT	1
5	UF6305	FHCS M5 X 0.8 X 10MM	4
6	UAM0541	FRONT ROLLER SET	2
7	UPM6473	CENTERING SUPPORT SEAT	1
8	UF0093	BHCS M8-1.25-16mm	4
9	UPM6478	SENSOR	1
10	UF3687	BHCS M5-0.8 X 12MM	2
11	UF7023	LW 5M	6
12	UF1827	FW REG M5	6
13	UPM3248	SENSOR SUPPORT	1
14	UPM6475	ROLLER COVER SUPPORT SEAT	1
15	UF3722	M8-1.25 NYLON LOCK NUT	6
16	UF1821	FW M8	21
17	UF5204	SHCS M8-1.25-20mm	2
18	UF9154	SHCS M5 X 0.8 X 12	4
19	UF5601	BHCS M5 X 0.8 X 6 LG	7
20	UPM6477	BASE BOTTOM COVER	1
21	UPM6470	BASE FRAME REINFORCEMENT	2
22	UF1540	HNR 3/8-16	8
23	UF4020	CARRIAGE BOLT 3/8-16 X 1	4
24	UAM0560	E-STOP CONTROL BOX	1
25	UAM0275	LEG ASSEMBLY	4
26	UF0810	SHCS M6-1 x 8mm	13
27	UF5900	NYLON LOCK NUT M6-1.0	6
28	UPM6472	BELT SIDE COVER	2
29	UPM6469	BASE FRAME WELDEMENT	1
30	UF6371	M10 LW	11
31	UF5900	NYLON LOCK NUT M6-1.0	4
32	UPM6479	DRAG CHAIN	1

7.2.1 UAM0541 – FRONT ROLLER SET

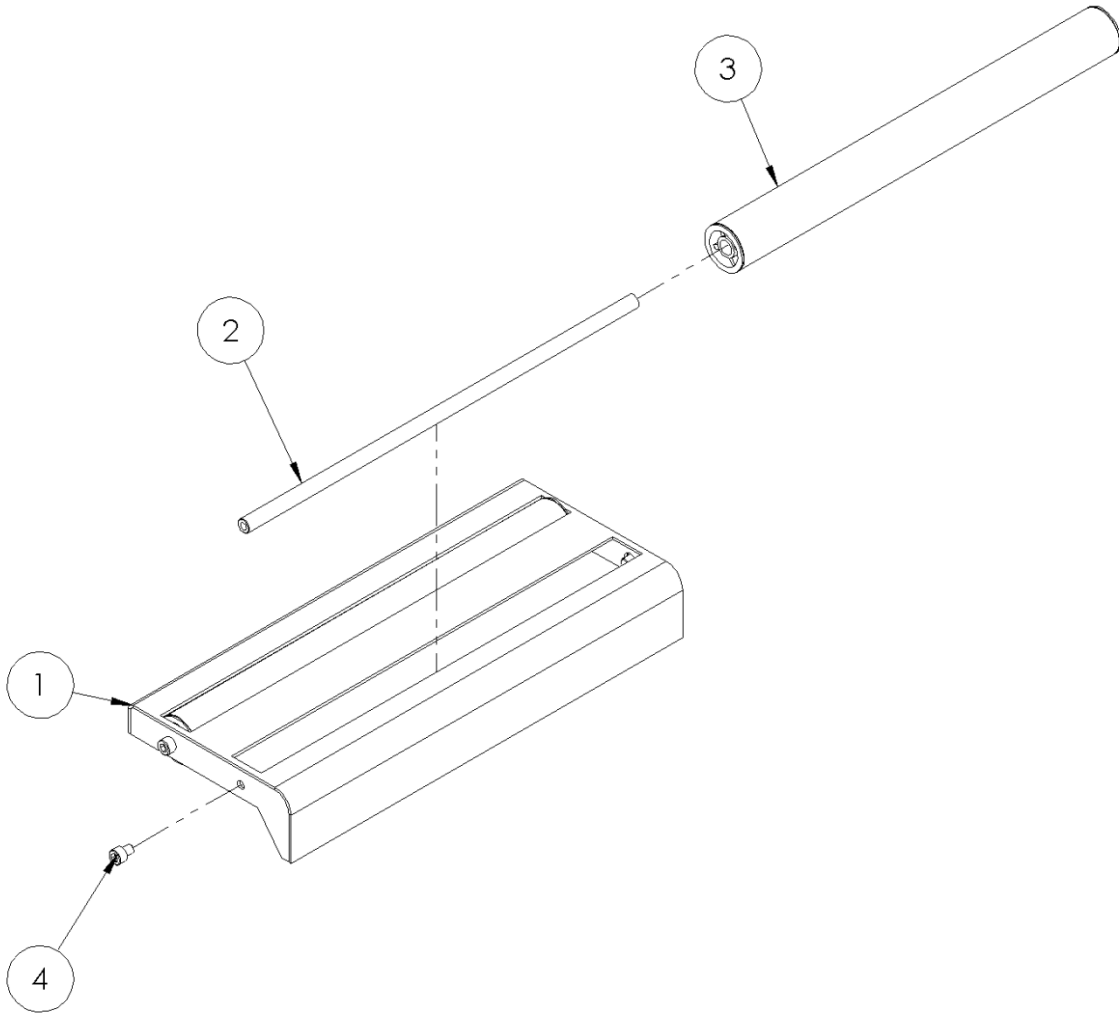

UAM0541 – FRONT ROLLER SET

ITEM NO.	PART NUMBER	DESCRIPTION	QTY.
1	UPM6550	FRONT ROLLER COVER	1
2	UPM6542	ROLLER AXLE	2
3	UPM6530	RSA2625-TB ROLLER	2
4	UF0810	SHCS M6-1 x 8mm	4

7.2.2 UAM0542 – REAR ROLLER SET

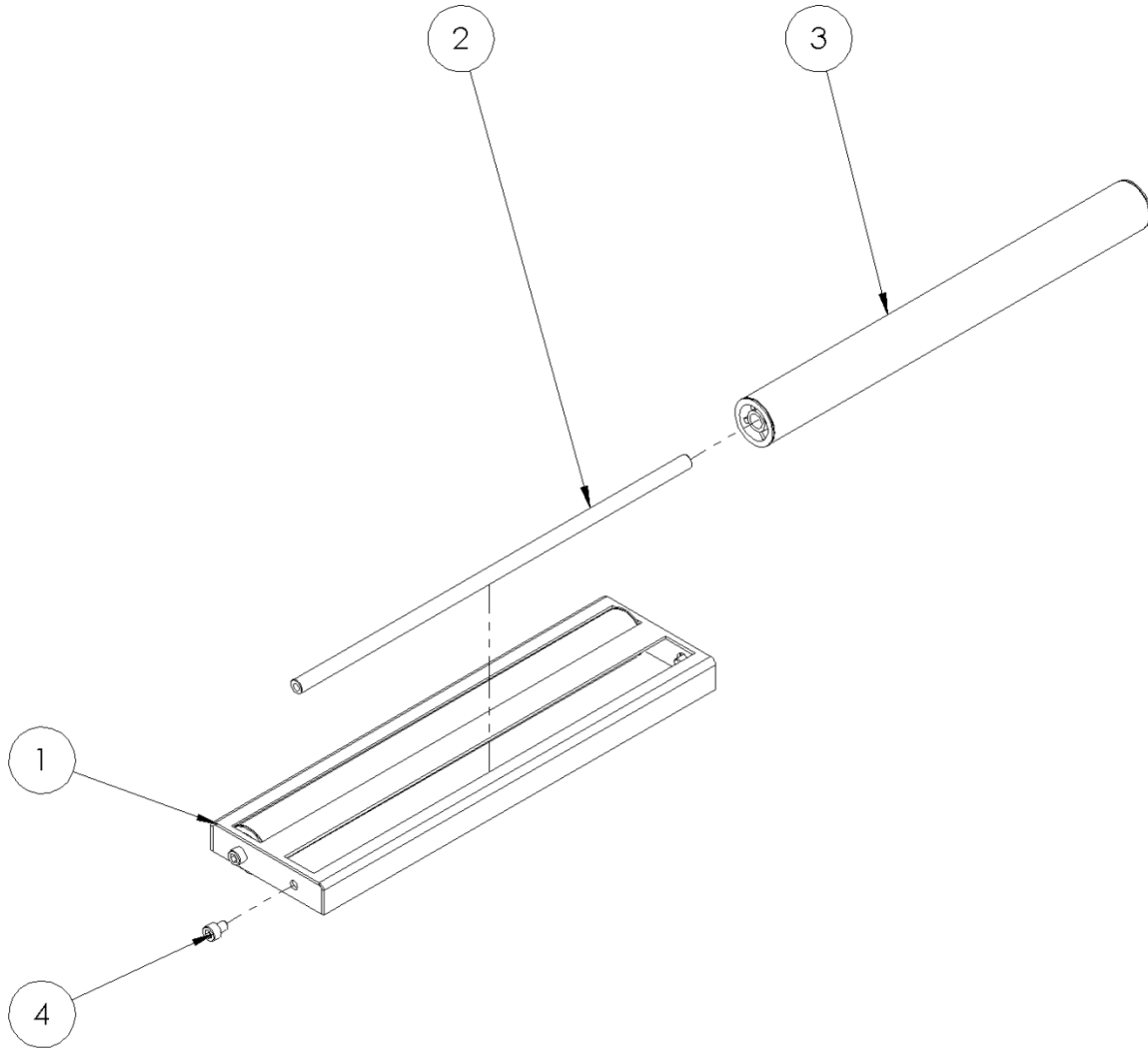

UAM0542 – REAR ROLLER SET

ITEM NO.	PART NUMBER	DESCRIPTION	QTY.
1	UPM6540	REAR ROLLER COVER	1
2	UPM6542	ROLLER AXLE	2
3	UPM6530	RSA2625-TB ROLLER	3
4	UF0810	SHCS M6-1 x 8mm	4

7.2.3 UAM0275 – LEG ASSEMBLY

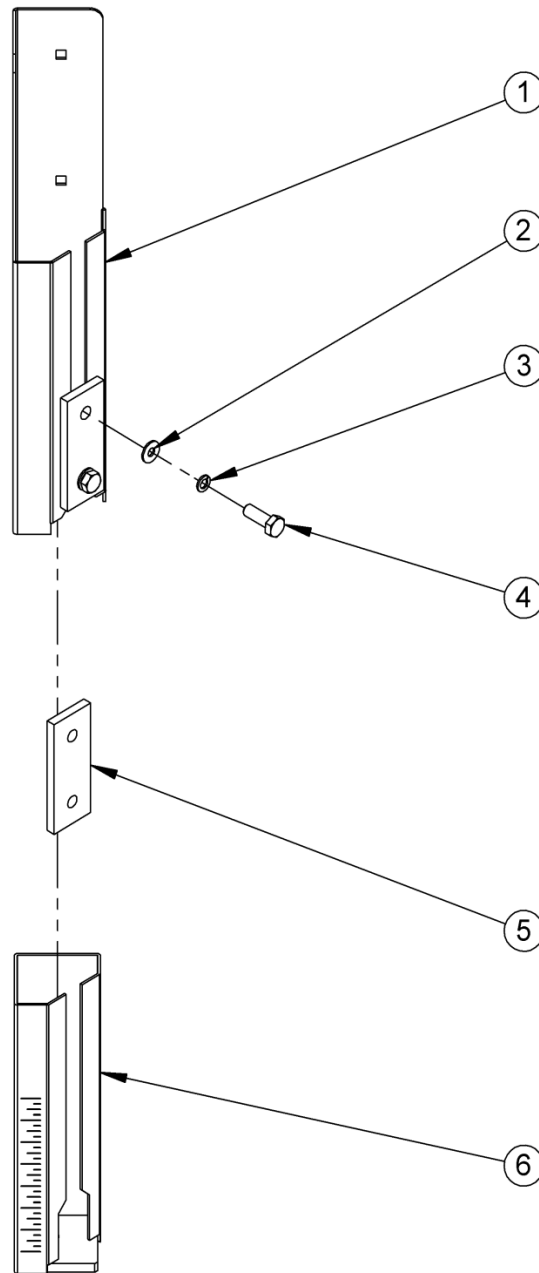

UAM0275 – LEG ASSEMBLY

ITEM NO.	PART NUMBER	DESCRIPTION	QTY.
1	UPM2830	LEG WELDMENT	1
2	UF4231	FW M8	2
3	UF4230	M10 LW	2
4	UF6393	HHCS M12-1.75-35mm	2
5	UPM7642	LEG FRICTION PLATE	1
6	UPM7642	LEG ADJUSTMENT	1

7.2.4 UAM0560 – E-STOP CONTROL BOX

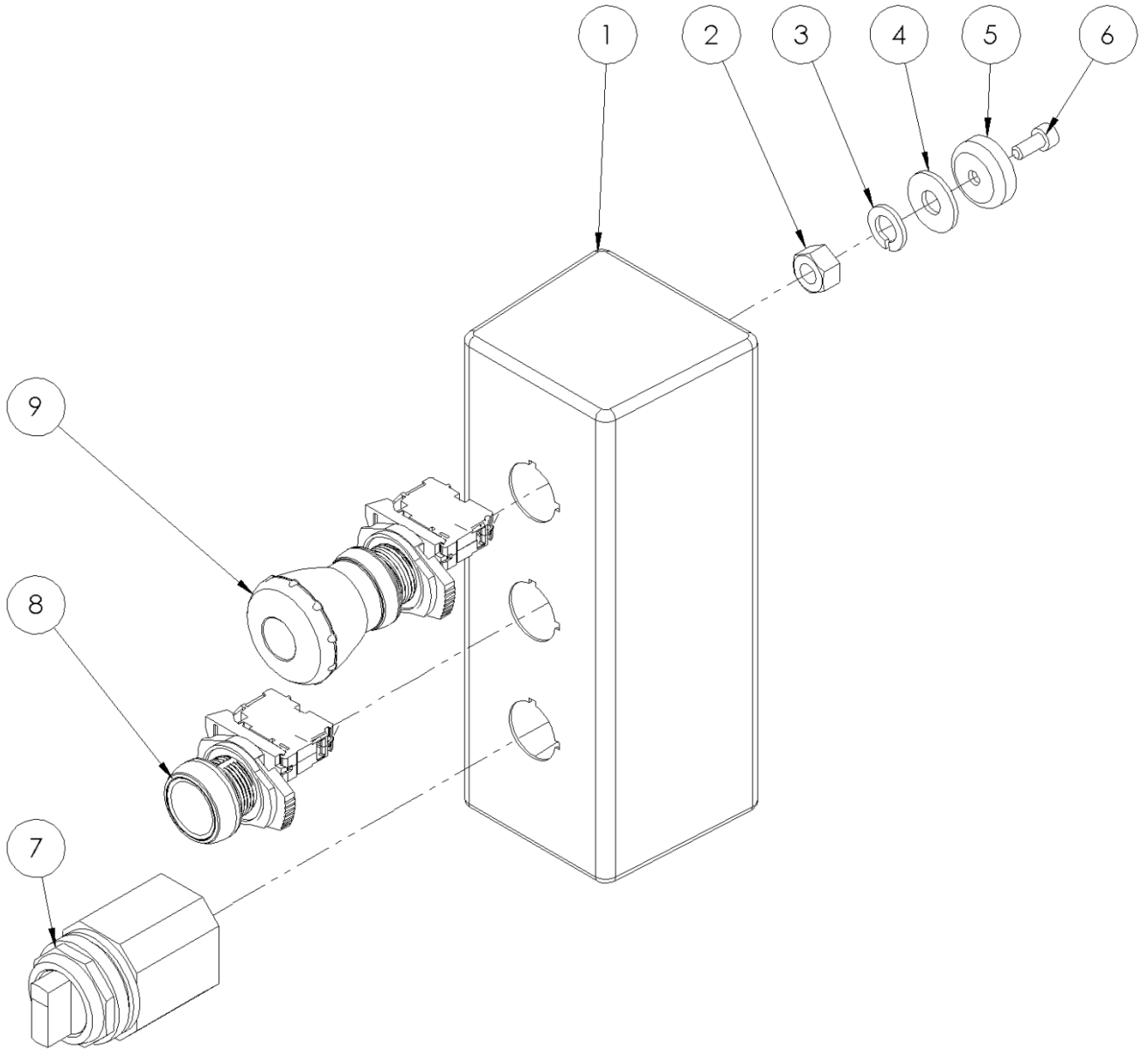

UAM0560 – E-STOP CONTROL BOX

ITEM NO.	PART NUMBER	DESCRIPTION	QTY.
1	UPM6480	CONTROL BOX HOUSING	1
2	UF1540	HNR 3/8-16	3
3	UF6371	LW M10	2
4	UF1821	FW M8	2
5	UPM6481	MAGNET $\varnothing 25 \times \varnothing 5.5 \times 8$ mm	2
6	UF9154	SHCS M5 X 0.8 X 12	2
7	UPM4517	SELECTOR SWITCH	1
8	UPM4821	START SWITCH	1
9	UPM5733	Emergency Button 22.5mm twist	1

7.3 USM0873 – COLUMN ASSEMBLY

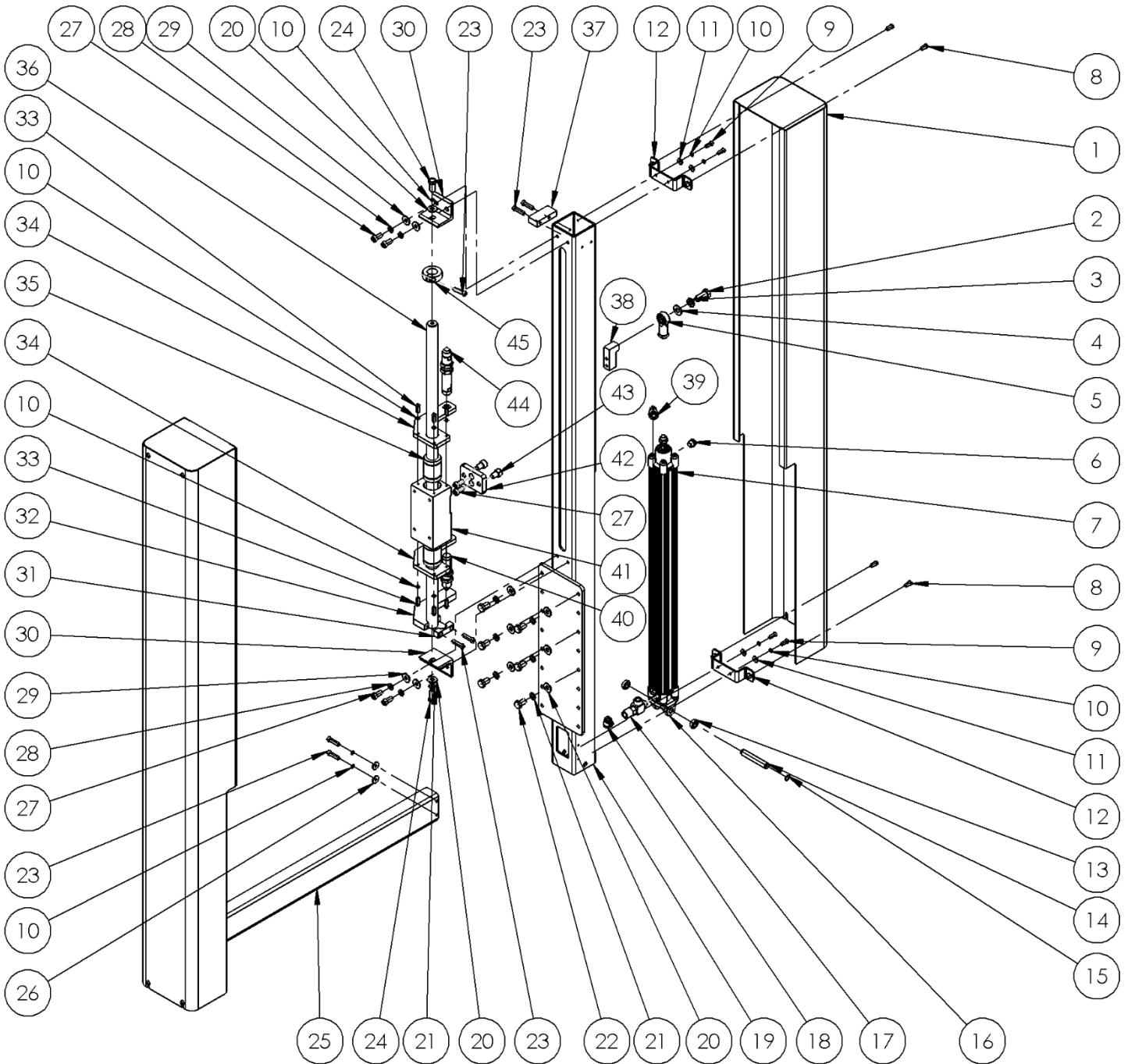

USM0873 – COLUMN ASSEMBLY

ITEM NO.	PART NUMBER	DESCRIPTION	QTY.
1	UPM6405	COLUMN COVER L&R	2
2	UF0125	HHCS M12-1.75 X 30MM	2
3	UF3733	SS LW M12	2
4	UF4231	M12 FW	2
5	UPM6420	12MM ROD END BEARING RH	2
6	UPM6429	SILENCER	2
7	UPM6421	AIR CYLINDER 600MM	2
8	UF1250EV	BHCS M6-1 x 16	8
9	UF0191	SHCS M5-0.8 X 16MM	8
10	UF7023	LW 5M	30
11	UF1827	FW REG M5	8
12	UPM6404	COVER BRACKET	4
13	UPM6425	20MM X 12.5MM X 7MM SPACER	4
14	UPM6403	CYLINDER PIN	2
15	UF6300	RET'G RING EXTERNAL 12mm	4
16	UPM6422	CYLINDER MOUNT	2
17	UPM6426	CHECK VALVE	2
18	UPM3192	ELBOW FTG.SWVL.8MM TUBE-G 1/4M	2
19	UPM6402	LEFT AND RIGHT SIDE COLUMN	2
20	UF3680	M10 FW	16
21	UF6371	M10 LW	14
22	UF0457	HHCS M10-1.25 X 20	12
23	UF6382	HHCS M10-1.5 x 25 mm	4
24	UPM6414	COLUMN SUPPORT CROSSBAR	1
25	UF0103	FW M6, 19mm OD, 2mm THK	4
26	UF4236	SHCS M6-1 X 30mm	14
27	UF3755	SS SHCS M8-1.25 x 20mm	12
28	UF0867	LW M8	8
29	UF1821	FW M8	8
30	UPM6415	MANDREL FIXING PLATE	4
31	UPM6406	LOCK BLOCK	2
32	UPM6407	LOWER BLOCK	2
33	UF5603	BHCS M5-0.8 x 20	16
34	UPM6418	BEARING SEAT COVER	4
35	UPM6541	LINEAR BEARING 25mm	4
36	UPM6419	LINEAR AXIS ROD	2
37	UPM6412	UPPER BLOCK	2
38	UPM6413	LIFT CONNECTION BLOCK	2
39	UPM3124	ELBOW LVT G 1/4MALE X10MM TUBE	2
40	UPM6423	SHOCK ABSORBER LOWER	2
41	UPM6416	LINEAR BEARING SLIDER	2
42	UPM6417	SLIDER CONNECTING PLATE	2
43	UF3648	SHCS M10-1.5- X 16	4
44	UPM6424	SHOCK ABSORBER UPPER	2
45	UPM1912	SHAFT COLLAR METRIC 25mm	2

7.4 USM0879 – TOP BELT ASSEMBLY

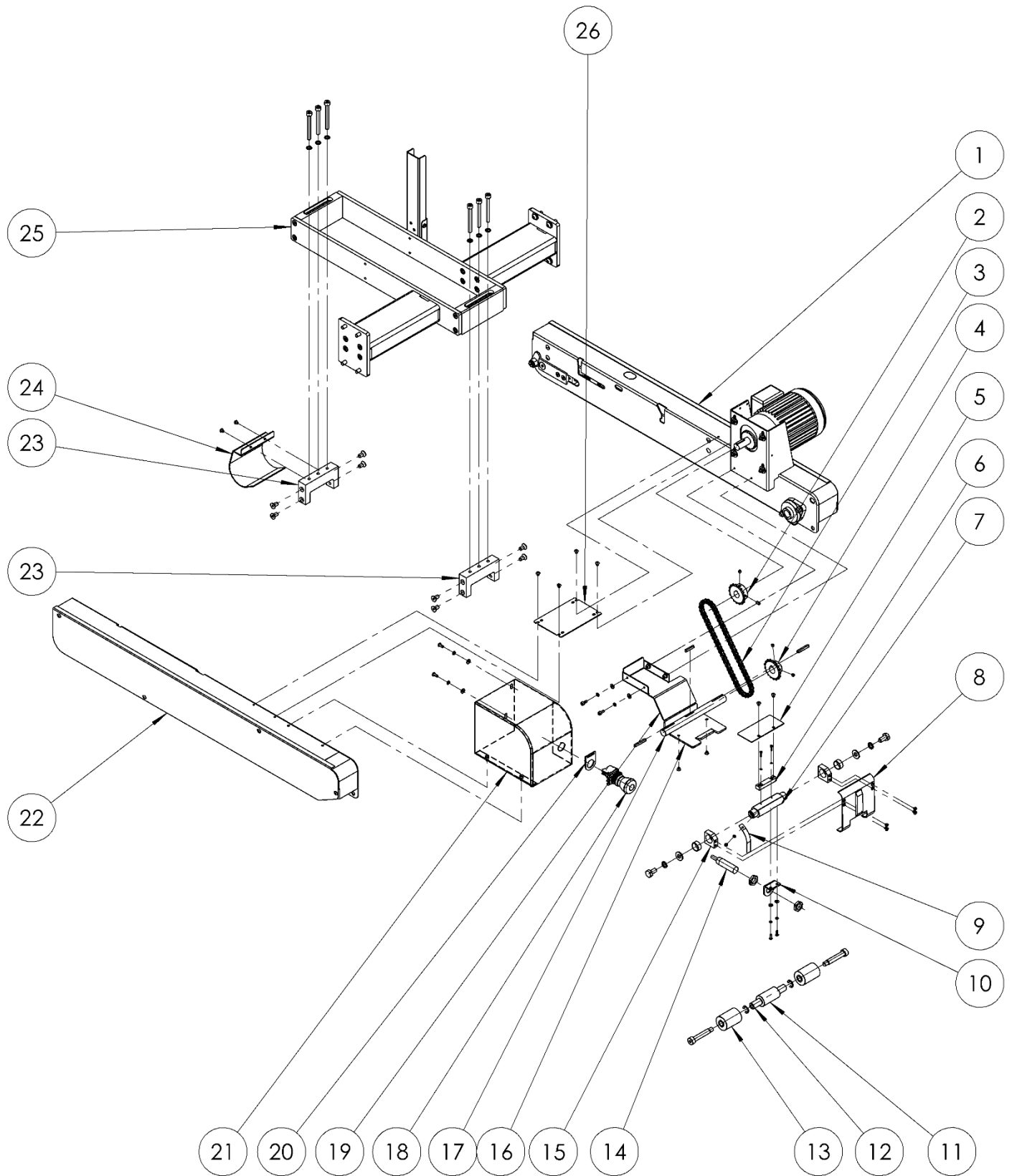

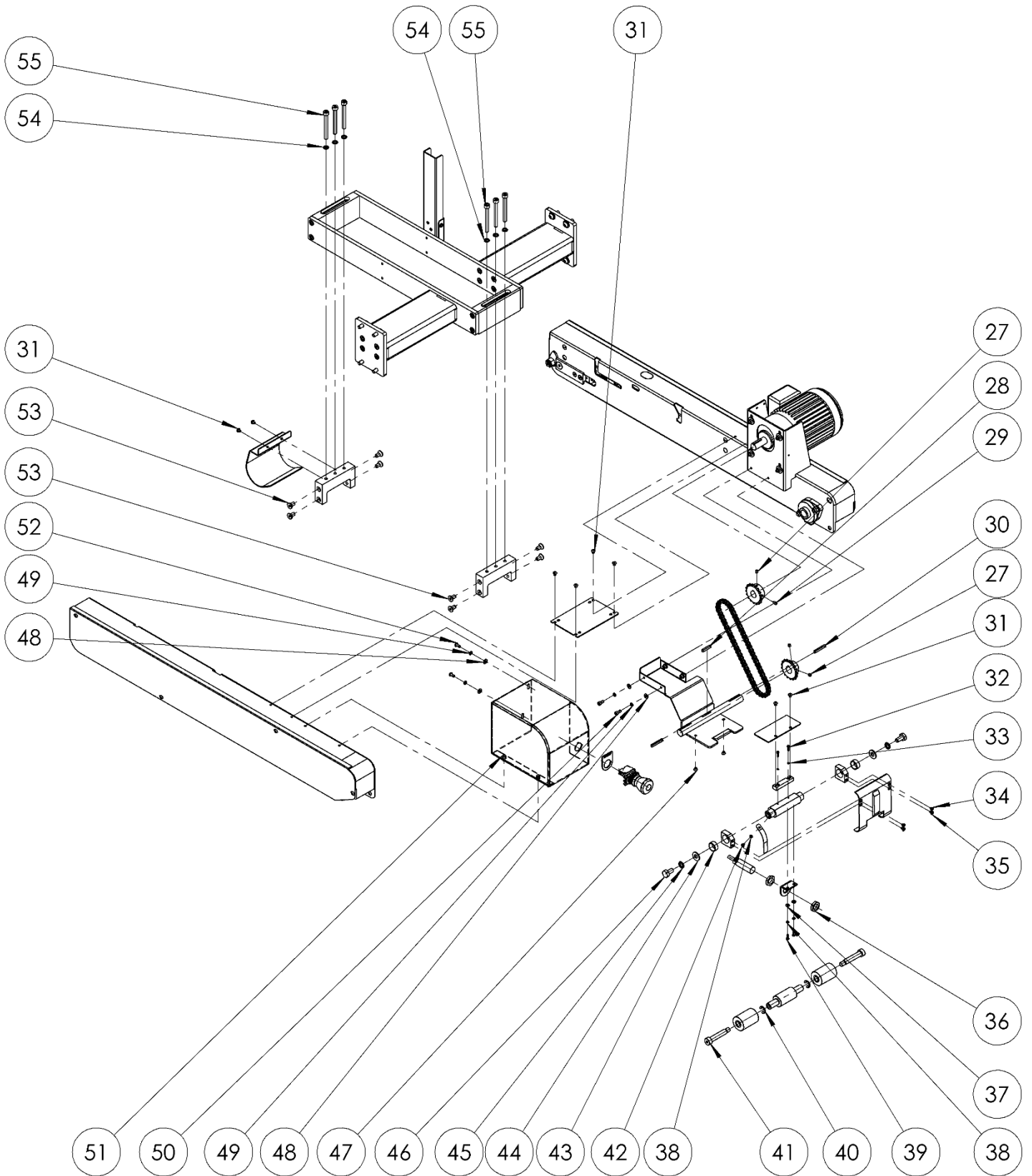

USM0879 – TOP BELT ASSEMBLY

ITEM NO.	PART NUMBER	DESCRIPTION	QTY.
1	USM0876	TOP BELT DRIVE SUB ASSY RH	1
2	UPM6318	DRIVE SPROCKET	1
3	UPM6320	CHAIN	1
4	UPM6319	SPROCKET	1
5	UPM6335	FRONT COVER	1
6	UPM6333	CONTACT BLOCK	1
7	UPM6330	SENSOR PLATE SHAFT	1
8	UPM6329	SENSOR PLATE C/W BOSS	1
9	UPM0011	FRONT BLADE	1
10	UPM0733	MOUNTING BRACKET FOR M18 SENSOR	1
11	UPM6331	MID ROLLER FOR SENSOR PLATE	1
12	UPM6328	SPINDLE ROLLER	1
13	UPM6332	SIDE ROLLER FOR SENSOR PLATE	2
14	UPM6364	FRONT PADDLE SENSOR	1
15	UPM2129	SENSOR PLT. PIVOT BLCK.	2
16	UPM6313	BOTTOM SIDE COVER	1
17	UPM6311	DRIVE SHAFT	1
18	UPM5733	E-STOP	1
19	UPM6309	REINFORCEMENT COVER PLATE	1
20	UPM5735	E-STOP TAG	1
21	UPM6308	UPPER CHAIN COVER	1
22	USM0875	TOP BELT DRIVE SUB ASSY LH	1
23	UPM6306	UPPER CONNECTING BLOCK	2
24	UPM6307	SENSOR PLATE	1
25	USM0874	BRIDGE ASSEMBLY	1
26	UPM6310	UPPER SEAT COVER	1
27	UF1411	SSS M6 X 6	3
28	UPM6322	SQUARE KEY ROUND ENDS	1
29	UF3683	SSS M6 X 10 MM	1
30	UF0192	SQUARE KEY ROUND ENDS 5X5-40	2
31	UF5601	BHCS M5 X 0.8 X 6 LG	8
32	UF5408	SHCS M3 X 12	2
33	UF3718	M3 LW	2
34	UF6352	FHCS M4-0.7 X 6MM	2
35	UF5401	FHCS M4 X 0.7 X 8 LG	2
36	UF0177	FRONT PADDLE SENSOR IG5399 NUT	2
37	UF0115	FW M4, 10mm OD, 1mm THK	2
38	UF3681	M4 LW	3
39	UF3649	BHCS M4-0.7 X 12	2
40	UF4314	RETAINING RING, EXTERNAL 12	2
41	UF0123	M12 X 55 SHOULDER SCREW	2
42	UF6374	BHCS M4-0.7X6	1
43	UPM6350	BUSHING 20X23X10	2
44	UF3680	M10 FW	2

45	UF6371	M10 LW	2
46	UF0457	HHCS M10-1.25 X 20	2
47	UF0119	FHCS M5-0.8 X 6MM	2
48	UF1827	FW REG M5	6
49	UF7023	M5 LW	6
50	UF9154	SHCS M5 X 0.8 X 12	4
51	UF0810	SHCS M6-1 X 8	2
52	UF3687	BHCS M5-0.8 X 12MM	2
53	UF3684	FHCS M8-1.25 X 16	8
54	UF0867	M8 LW	6
55	UF0124	SHCS M8-1.25 X 75MM	6

7.4.1 USM0874 – BRIDGE ASSEMBLY

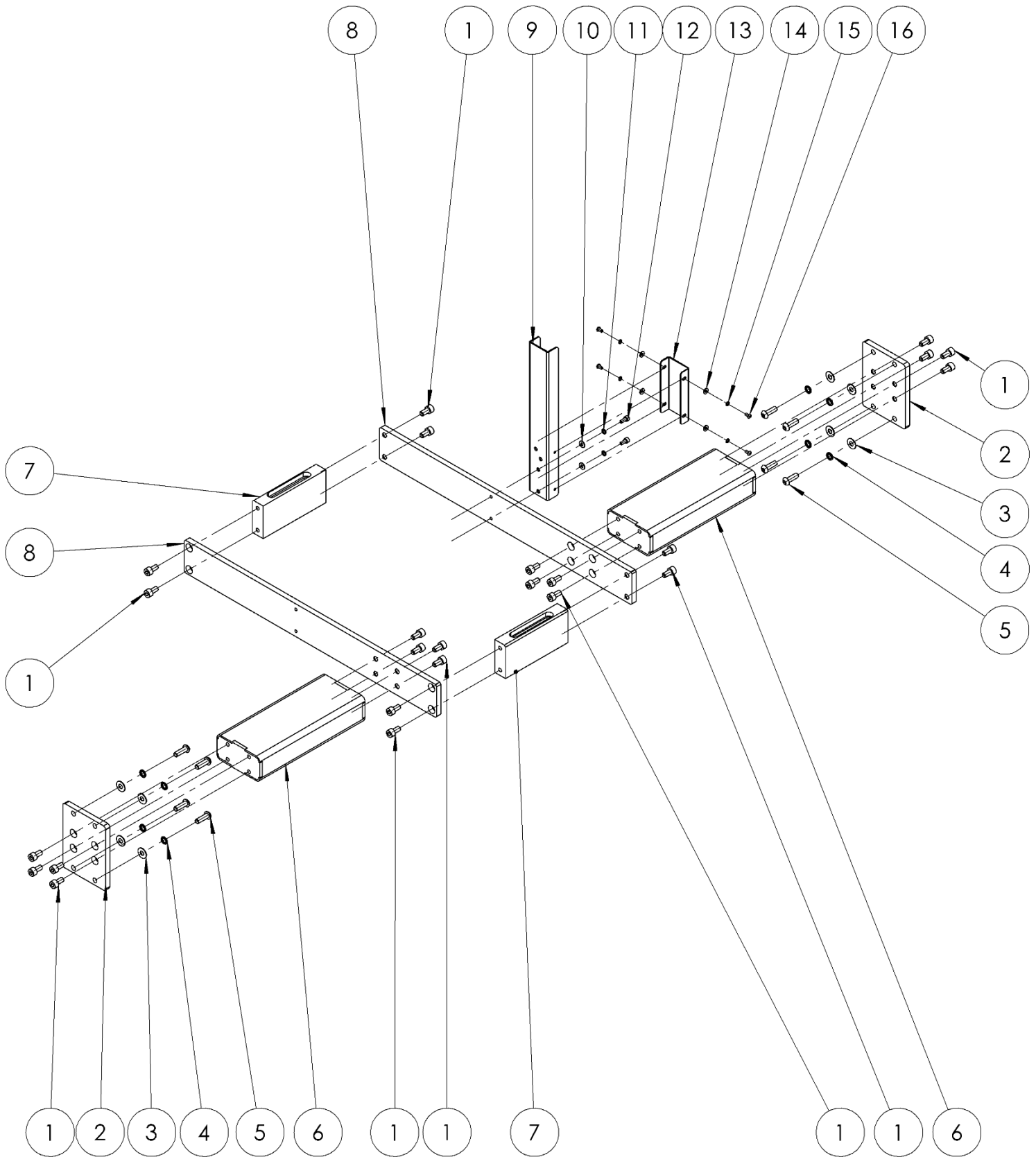

USM0874 – BRIDGE ASSEMBLY

ITEM NO.	PART NUMBER	DESCRIPTION	QTY.
1	UF6367	SHCS M8-1.25 X 16	24
2	UPM6545	COLUMN ATTACHMENT PLATE	2
3	UF0105	FW M8, 19mm OD, 1mm THK	8
4	UF0867	M8 LW	8
5	UF3802	BHCS M8-1.25 X 25MM	8
6	UPM6546	SIDE ARM WELDMENT	2
7	UPM6547	FIXING PLATE	2
8	UPM6543	SIDE PLATE	2
9	UPM6548	LINE RAIL COVER LH	1
10	UF1827	FW REG M5	2
11	UF7023	M5 LW	2
12	UF9154	SHCS M5 X 0.8 X 12	2
13	UPM6544	LINE RAIL COVER RH	1
14	UF0115	FW M4, 10mm OD, 1mm THK	4
15	UF3681	M4 LW	4
16	UF3685	BHCS M4-0.7 X 8	4

7.4.2 USM0875 – TOP BELT DRIVE ASSEMBLY LH

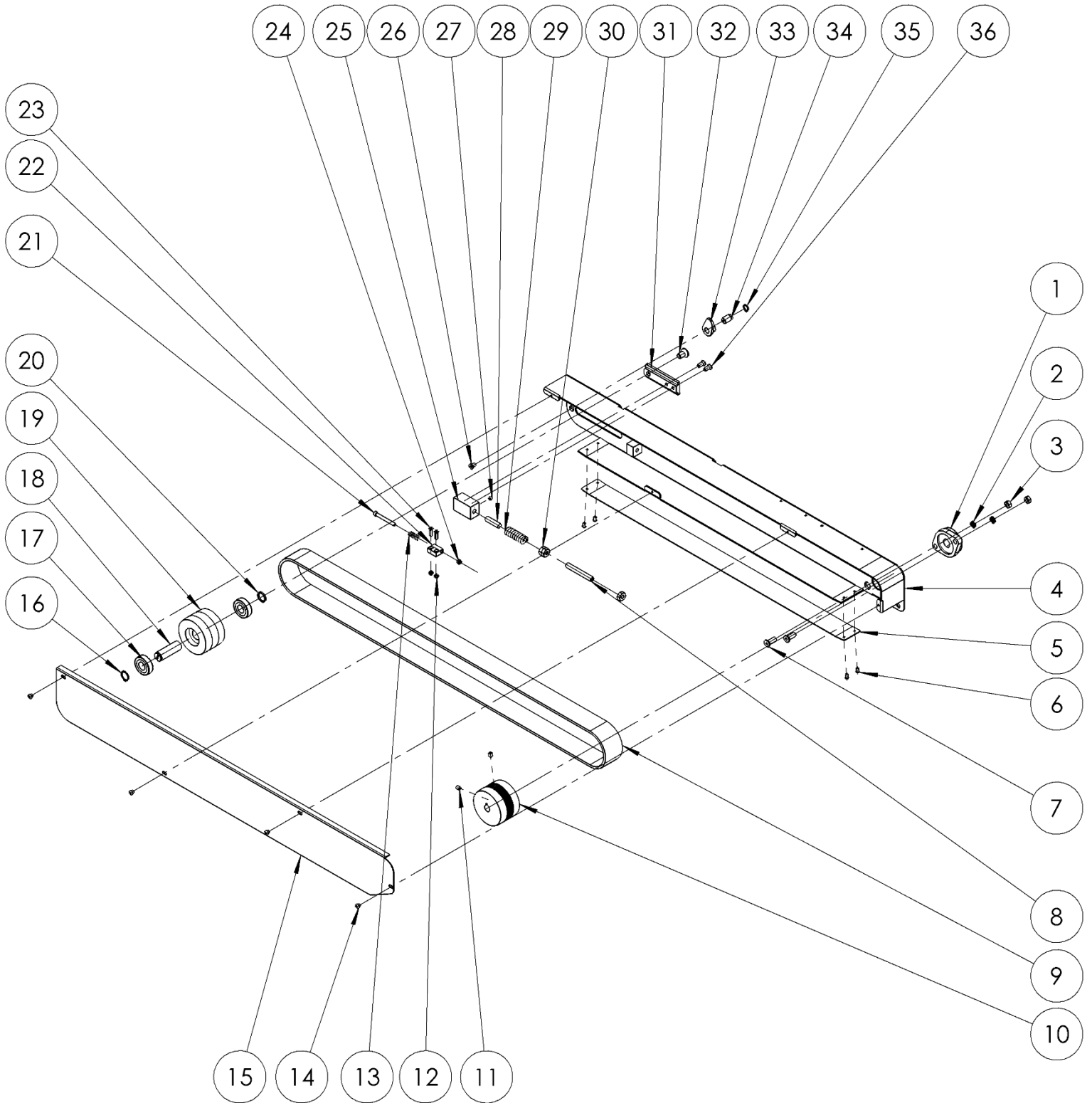

USM0875 – TOP BELT DRIVE ASSEMBLY LH

ITEM NO.	PART NUMBER	DESCRIPTION	QTY.
1	UPM0339	FLANGE BEARING 3/4" ID	1
2	UF0867	M8 LW	2
3	UF0866	HEX NUT M8	2
4	UPM6561	L.H. DRIVE SECTION WELDMENT	1
5	UPM0029	STRIP	1
6	UF3691	POP RIVET 4mm	4
7	UF0091	FHCS M8 - 1.25 X 25	2
8	UF1400	SSS HK 3/8-16 X 3	1
9	UPM6334	DRIVE BELT 50X2020	1
10	UPM4450	DRIVE PULLEY	1
11	UF3683	SSS M6 X 10 MM	2
12	UF6376	NYLON LOCK NUT M4-0.7	2
13	UPM2835	SS COMP.SPRING SWIVEL T.H. ASSY	1
14	UF5601	BHCS M5 X 0.8 X 6 LG	4
15	UPM6323	BELT GUARD LEFT	1
16	UF2220EV	EXT RET'G RING 19mm	1
17	UPM0324	BEARING PULLEY	2
18	UPM1233	IDLER PULLEY SHAFT 2"	1
19	UPM0259	IDLER PULLEY	1
20	UPM6317	SPACER	1
21	UF0121	SHCS M5-0.8 X 55MM	1
22	UPM6312	SPRING HOLDER BLOCK	1
23	UF3693	FHCS M4-0.7 X 20	2
24	UF3393	NYLON LOCK NUT M5-0.8	1
25	UPM0101EV	TENSIONNER SPRING HOLDER	1
26	UF1042	FHCS M6 X 1 X 12	1
27	UF1411	SSS M6 X 6	1
28	UPM0112	3/8 X 1 1/2 DOWEL PIN	1
29	UPM0038	DIE SPRING (DRIVE BASE)	1
30	UF1540	HEX NUT G5Z 3/8-16	3
31	UPM6074	TENSIONER SLIDE	1
32	UF6397	FHCS M10-1.5 X 20MM	1
33	UPM6314	BELT TENSIONER LH	1
34	UPM6316	ADJUSTER MANDREL	1
35	UF6300	RETAINING RING 12MM SHAFT	1
36	UF0960EV	FHCS M6 X 16L	2

7.4.3 USM0876 – TOP BELT DRIVE ASSEMBLY RH

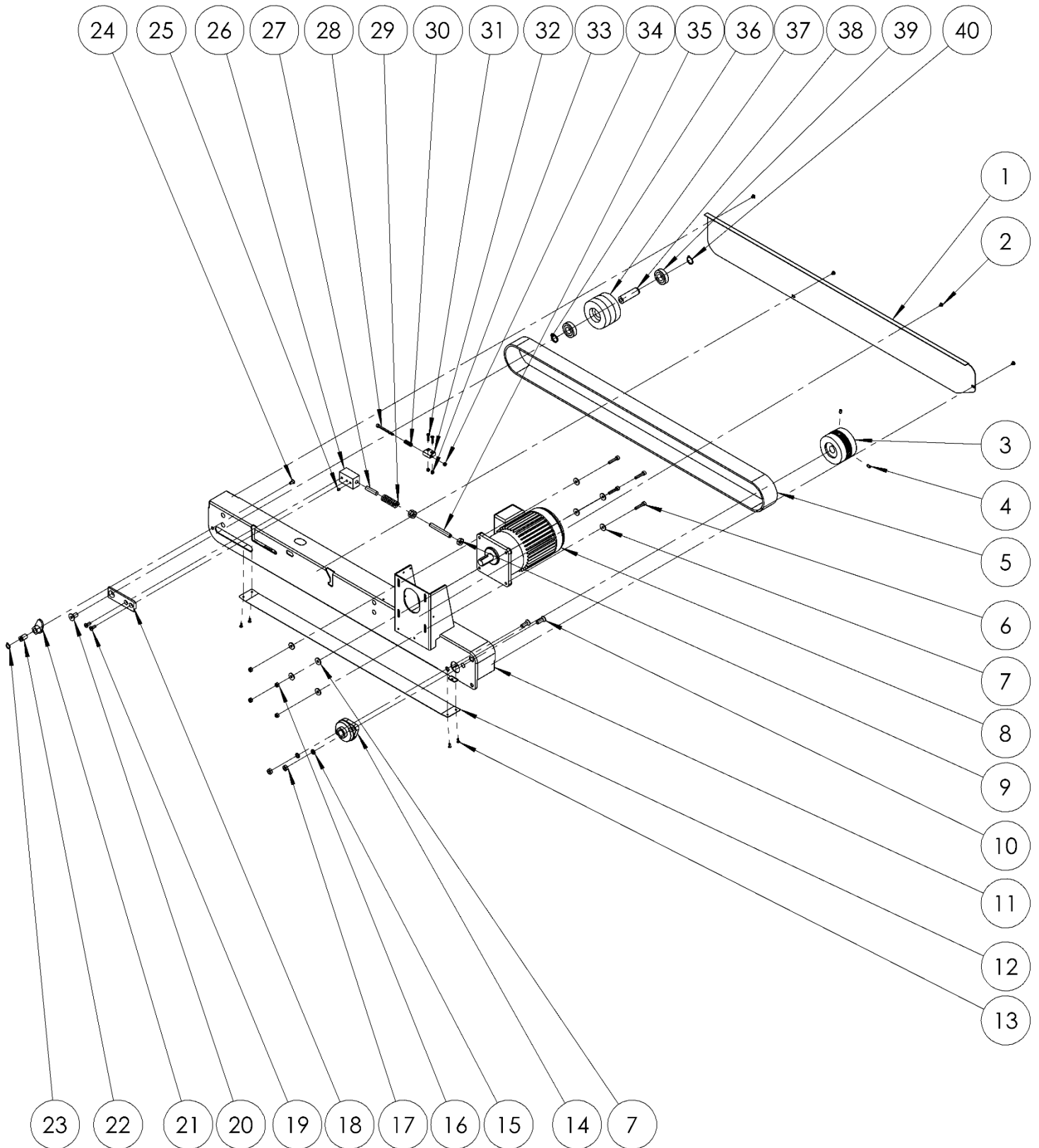

USM0876 – TOP BELT DRIVE ASSEMBLY RH

ITEM NO.	PART NUMBER	DESCRIPTION	QTY.
1	UPM6336	BELT GUARD RIGHT	1
2	UF5601	BHCS M5 X 0.8 X 6 LG	4
3	UPM4450	DRIVE PULLEY	1
4	UF3683	SSS M6 X 10 MM	2
5	UPM6334	DRIVE BELT 50X2020	1
6	UF4236	SHCS M6-1.0 X 30	4
7	UF0103	FW M6, 19mm OD, 2mm THK	8
8	UPM6591	1/4 HP MOTOR W/12.5:1	1
9	UF1540	HEX NUT G5Z 3/8-16	3
10	UF0091	FHCS M8 - 1.25 X 25	2
11	UPM6562	TOP BELT DRIVE SUB ASSY RH	1
12	UPM0029	STRIP	1
13	UF3691	Pop Rivet 4mm	4
14	UPM0339	FLANGE BEARING 3/4" ID	1
15	UF0867	M8 LW	2
16	UF5900	NYLON LOCK NUT M6-1.0	4
17	UF0866	HEX NUT M8	2
18	UPM6074	TENSIONER SLIDE	1
19	UF0960EV	FHCS M6 X 16L	2
20	UF6397	FHCS M10-1.5 X 20MM	1
21	UPM6315	BELT TENSIONER RH	1
22	UPM6316	ADJUSTER MANDREL	1
23	UF6300	RETAINING RING 12MM SHAFT	1
24	UF1042	FHCS M6 X 1 X 12	1
25	UF1411	SSS M6 X 6	1
26	UPM0101EV	TENSIONER SPRING HOLDER	1
27	UPM0112	3/8 X 1 1/2 DOWEL PIN	1
28	UF0121	SHCS M5-0.8 X 55MM	1
29	UPM0038	DIE SPRING (DRIVE BASE)	1
30	UPM2835	SS COMP.SPRING SWIVEL T.H. ASSY	1
31	UF3693	FHCS M4-0.7 X 20	2
32	UPM6312	SPRING HOLDER BLOCK	1
33	UF6376	NYLON LOCK NUT M4-0.7	2
34	UF3393	NYLON LOCK NUT M5-0.8	1
35	UF1400	SSS HK 3/8-16 X 3	1
36	UPM6317	SPACER	1
37	UPM0259	IDLER PULLEY	1
38	UPM1233	IDLER PULLEY SHAFT 2"	1
39	UPM0324	BEARING PULLEY	2
40	UF2220EV	EXT RET'G RING 19mm	1

PAGE
INTENTIONALLY
LEFT BLANK

7.5 UAM0411 – ELECTRIC CONTROL BOX ASSEMBLY

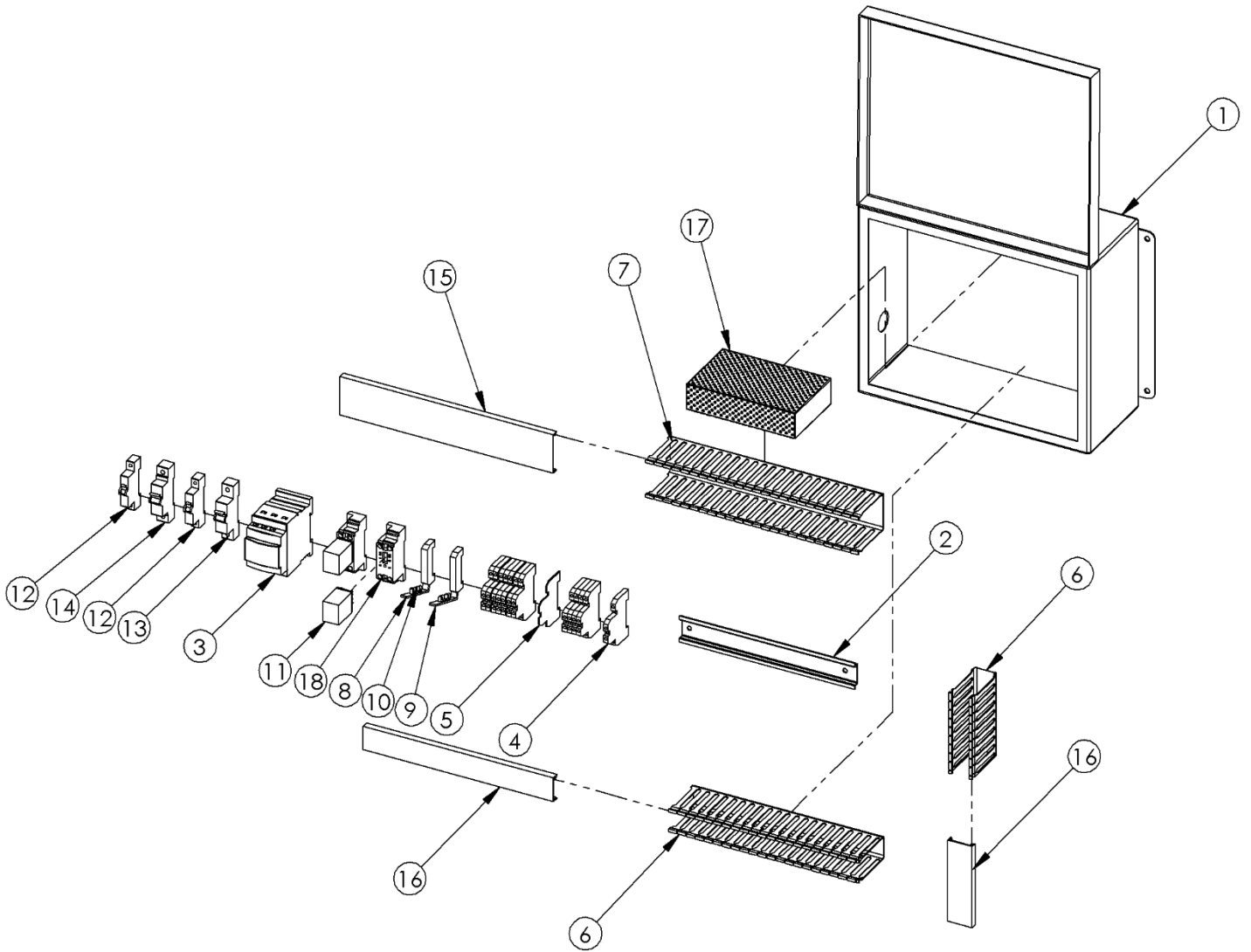

UAM0411 – ELECTRIC CONTROL BOX ASSEMBLY

ITEM NO.	PART NUMBER	DESCRIPTION	QTY.
1	UPM1970	BOX HOFF 12"X10"X5"	1
2	UPM0407	DIN RAIL	1
3	UPM7691	MOTOR STARTER TELEMEC 110VAC	1
4	UPM2880	TERMINAL BLOCK DOUBLE TW	12
5	UPM2881	TERMINAL BLOCK DOUBLE END CAP	3
6	UPM0226	WIRE WAY 30mm	2
7	UPM0254	WIRE WAY 50mm	1
8	UPM7428EV	FUSE TERMINAL BLOCK 5mm, WHITE LED	1
9	UPM4466	FUSE TERMINAL BLOCK 5mm, RED LED	1
10	UPM7120	FUSE 5mm X 20mm 1AMP/250V IEC	2
11	UPM7558	OMRON RELAY 2 POLE 24 VDC	2
12	UPM7689	CIRCUIT BREAKER AUX CONTACT	2
13	UPM7690	MINIATURE CIRCUIT BREAKER 4AMP	1
14	UPM7692	MINIATURE CIRCUIT BREAKER 3AMP	1
15	UPM0255	COVER 50mm	1
16	UPM0177	COVER 30mm	2
17	S-50-24	POWER SUPPLY	1
18	UPM7709	RELAY SOCKET	2

7.6 USM0880 – BOTTOM DRIVE ASSEMBLY

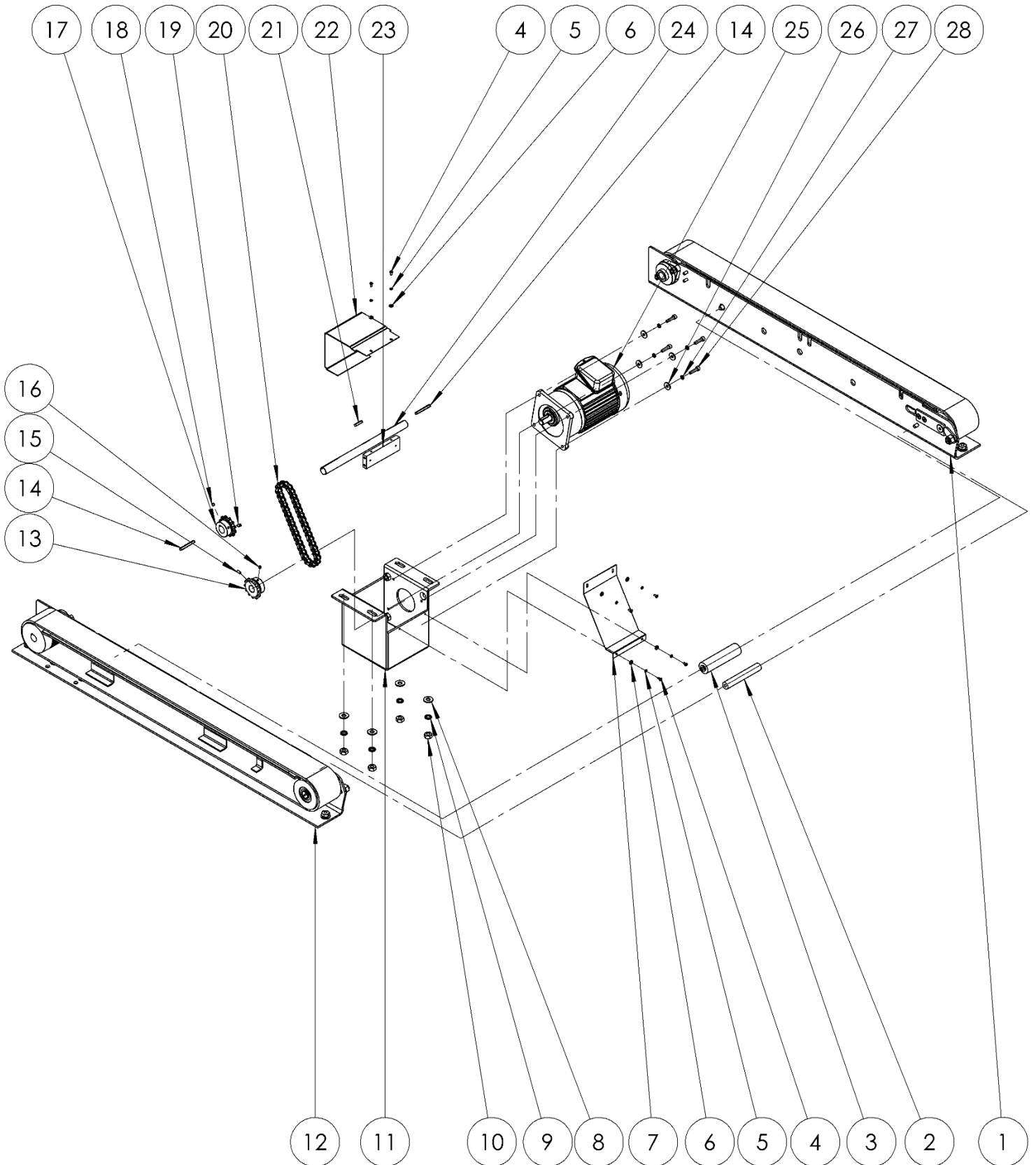

USM0880 – BOTTOM DRIVE ASSEMBLY

ITEM NO.	PART NUMBER	DESCRIPTION	QTY.
1	UAM0539	BOTTOM BELT DRIVE SECTION RH	1
2	UPM6391	SPACER .75" DIA	1
3	UPM6393	SPACER - 1.25" DIA	1
4	UF3685	BHCS M4-0.7 X 8	6
5	UF3681	M4 LW	6
6	UF0115	FW M4, 10mm OD, 1mm THK	6
7	UPM6388	FRONT CHAIN GUARD	1
8	UF3680	M10 FW	16
9	UF6371	M10 LW	12
10	UF6314	M10-1.5-HNR	4
11	UPM6389	MOTOR BOX DRIVE	1
12	UAM0538	BOTTOM BELT DRIVE SECTION LH	1
13	UPM6396	SPROCKET #40 12T 18 W/ 5mm KEY	1
14	UF0193	SQUARE KEY ROUND ENDS 5X5X50	2
15	UF3716	SSS M5 X 10MM	1
16	UF3731	SSS M5-0.8 X 6MM	1
17	UPM6395	SPROCKET #40 12T .75 BORE W/ KEY	1
18	UF1411	SSS M6 X 6	3
19	UF3683	SSS M6 X 10 MM	5
20	UPM6397	CHAIN #40	1
21	UF0194	SQUARE KEY ROUND ENDS 5X5X25	1
22	UPM6385	BACK CHAIN GUARD	1
23	UPM6390	GUARD MOUNTING BLOCK	1
24	UPM6299	DRIVE SHAFT	1
25	UPM7116CD	MOTOR 1/3 HP 1:24.1	1
26	UF0103	FW M6, 19mm OD, 2mm THK	4
27	UF6363	M6 LW	4
28	UF0630EV	SHCS M6 X L25	4

7.6.1 UAM0538 – BOTTOM DRIVE SECTION LH

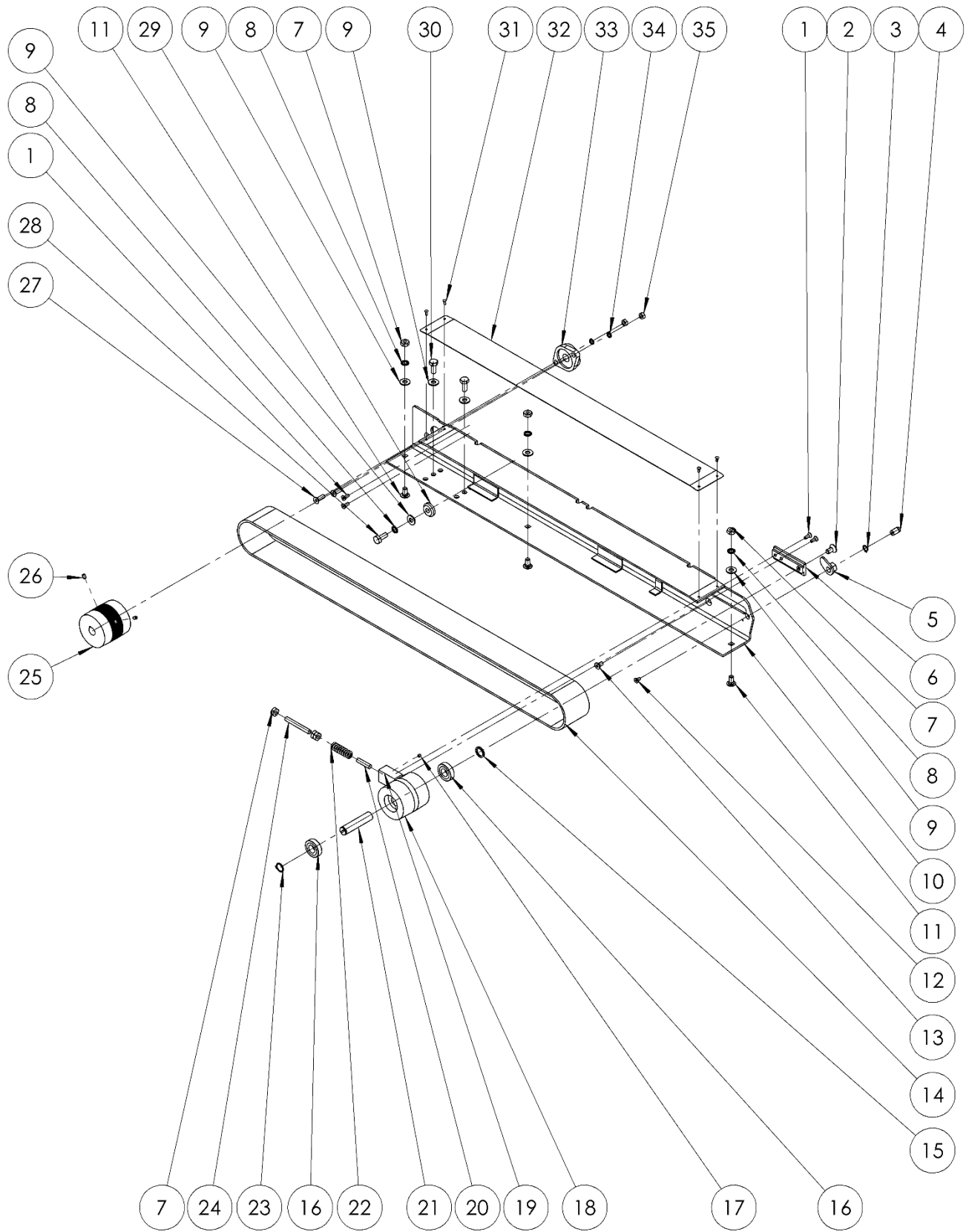

UAM0538 – BOTTOM DRIVE SECTION LH

ITEM NO.	PART NUMBER	DESCRIPTION	QTY.
1	UF0960EV	FHCS M6 X 16L	4
2	UF6397	FHCS M10-1.5 X 20MM	1
3	UF6300	RETAINING RING 12MM SHAFT	1
4	UPM6316	ADJUSTER MANDREL	1
5	UPM6315	BELT TENSIONER LH	1
6	UPM6392	TENSIONER SLIDE	1
7	UF1540	HEX NUT G5Z 3/8-16	6
8	UF6371	M10 LW	4
9	UF3680	M10 FW	6
10	UPM6563	L.H. BTM DRIVE SECTION WELDMENT	1
11	UF4006	CARRIAGE BOLT 3/8-1/16NC X 3/4	3
12	UF1042	FHCS M6 X 1 X 12	1
13	UF3684	FHCS M8-1.25 X 16	1
14	UPM6398	BELT DRIVE 75 X 2136	1
15	UPM0109	IDLER PULLEY SPACER	1
16	UPM0324	BEARING PULLEY	2
17	UF1411	SSS M6 X 6	1
18	UPM4070	IDLER PULLEY	1
19	UPM1234	COMPRESSION BLOCK	1
20	UPM0112	3/8 X 1 1/2 DOWEL PIN	1
21	UPM4072	IDLER SHAFT	1
22	UPM0038	DIE SPRING (DRIVE BASE)	1
23	UF2220EV	EXT RET'G RING 3/4" SHAFT	1
24	UF1400	SSS HK 3/8-16 X 3	1
25	UPM4069	DRIVE PULLEY	1
26	UF3683	SSS M6 X 10 MM	2
27	UF0091	FHCS M8 - 1.25 X 25	2
28	UF6382	HHCS M10-1.5 X 25 MM	1
29	UPM6394	BEVELED WASHER	1
30	UF3647	HHCS M10 X 1.25 X 25	2
31	UF3691	Pop Rivet 4mm	4
32	UPM6399	STRIP UHMW 3" X .03"THK	35
33	UPM0339	FLANGE BEARING 3/4" ID	1
34	UF0867	M8 LW	2
35	UF0866	HEX NUT M8	2

7.6.2 UAM0539 – BOTTOM DRIVE SECTION RH

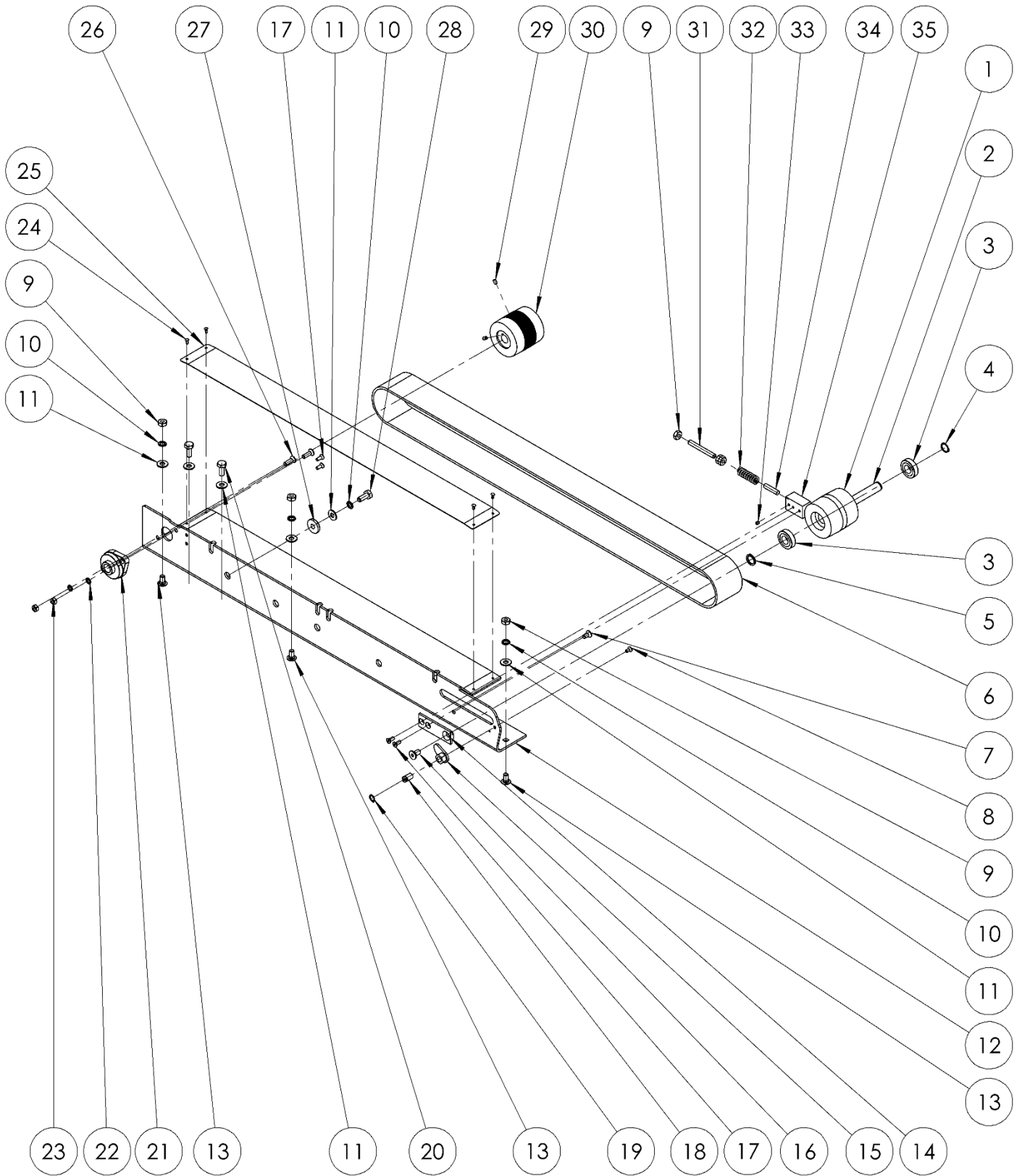

UAM0539 – BOTTOM DRIVE SECTION RH

ITEM NO.	PART NUMBER	DESCRIPTION	QTY.
1	UPM4070	IDLER PULLEY	1
2	UPM4072	IDLER SHAFT	1
3	UPM0324	BEARING PULLEY	2
4	UF2220EV	EXT RET'G RING 3/4" SHAFT	1
5	UPM0109	IDLER PULLEY SPACER	1
6	UPM6398	BELT DRIVE 75 X 2136	1
7	UF3684	FHCS M8-1.25 X 16	1
8	UF1042	FHCS M6 X 1 X 12	1
9	UF1540	HEX NUT G5Z 3/8-16	6
10	UF6371	M10 LW	4
11	UF3680	M10 FW	6
12	UPM6564	R.H. BTM DRIVE SECTION WELDMENT	1
13	UF4006	CARRIAGE BOLT 3/8-1/16NC X 3/4	3
14	UPM6392	TENSIONER SLIDE	1
15	UPM6314	BELT TENSIONER RH	1
16	UF6397	FHCS M10-1.5 X 20MM	1
17	UF0960EV	FHCS M6 X 16L	4
18	UPM6316	ADJUSTER MANDREL	1
19	UF6300	RETAINING RING 12MM SHAFT	1
20	UF3647	HHCS M10 X 1.25 X 25	2
21	UPM0339	FLANGE BEARING 3/4" ID	1
22	UF0867	M8 LW	2
23	UF0866	HEX NUT M8	2
24	UF3691	Pop Rivet 4mm	4
25	UPM6399	STRIP UHMW 3" X .03"THK	35
26	UF0091	FHCS M8 - 1.25 X 25	2
27	UPM6394	BEVELED WASHER	1
28	UF6382	HHCS M10-1.5 X 25 MM	1
29	UF3683	SSS M6 X 10 MM	2
30	UPM4069	DRIVE PULLEY	1
31	UF1400	SSS HK 3/8-16 X 3	1
32	UPM0038	DIE SPRING (DRIVE BASE)	1
33	UF1411	SSS M6 X 6	1
34	UPM0112	3/8 X 1 1/2 DOWEL PIN	1
35	UPM1234	COMPRESSION BLOCK	1

7.7 USM0878 – CENTERING MECHANISM

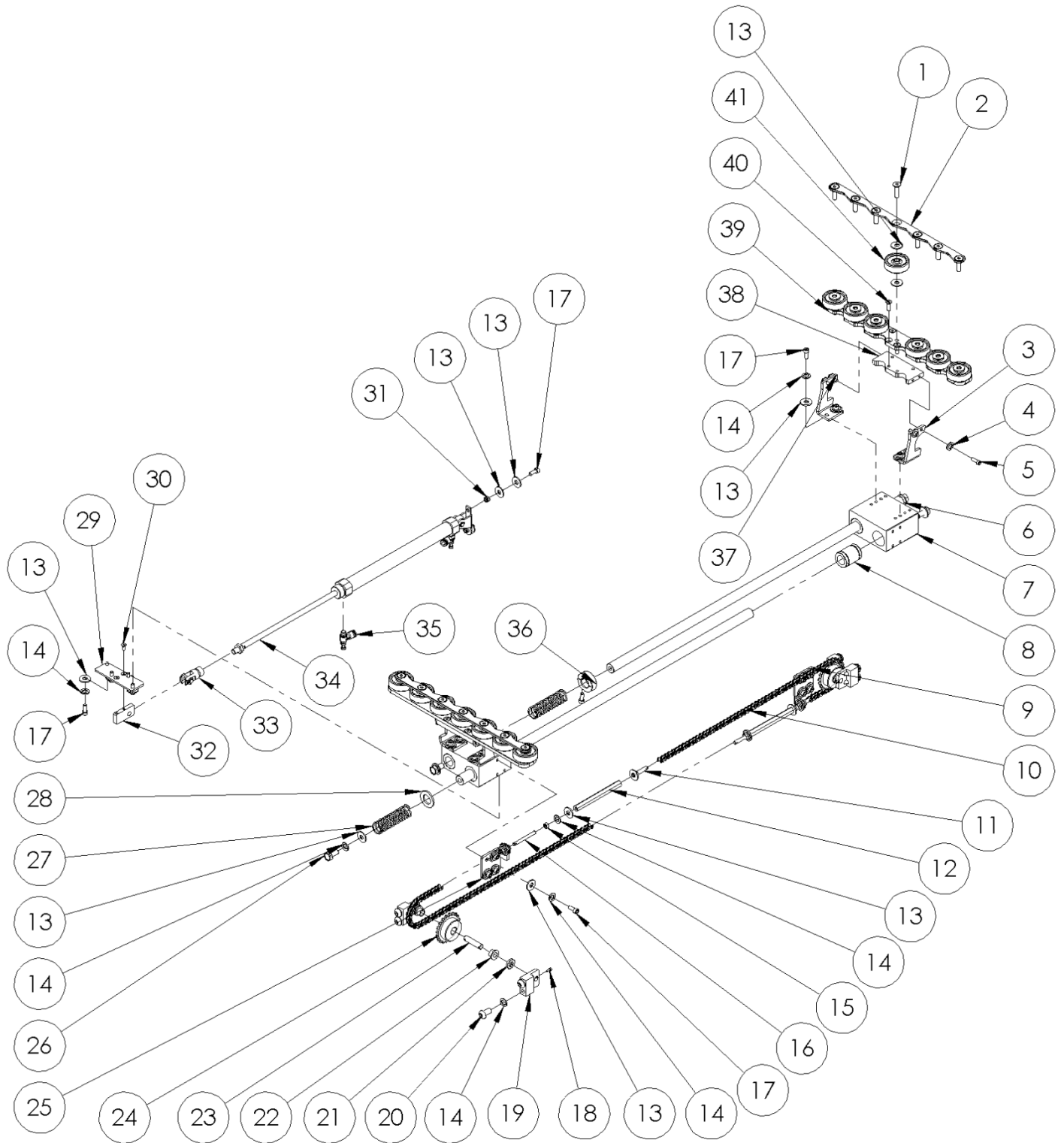

USM0878 – CENTERING MECHANISM

ITEM NO.	PART NUMBER	DESCRIPTION	QTY.
1	UF6329	M8-1.25 X 30MM FHCS	14
2	UPM6441	TOP ROLLER PLATE	2
3	UPM6433	SPACER FOR ROLLER PLATE (RIGHT)	2
4	UF6371	LW M10	8
5	UF0195	M5-0.8 x 16 SHCS	8
6	UPM6450	20MM LINEAR SHAFT	2
7	UPM6434	CROSS SHAFT BLOCK	2
8	UPM6449	20MM LINEAR BEARING	8
9	UPM6438	BTM CHAIN ADAPTOR BRACKET	1
10	UPM6445	CHAIN #35 619MM	2
11	UPM3259	CHAIN THREADED LINK LH	2
12	UPM3255	TURNBUKLE	2
13	UF1821	FW M8	57
14	UF6371	M10 LW	33
15	UF3637	HNR M6-1.0	1
16	UPM3260	CHAIN THREADED LINK R.H.	2
17	UF3187	SS SHCS M6-1 x 16 mm	23
18	UF6400	SHCS M3-0.5 x 8	4
19	UPM6430	SPROCKET SUPPORT	4
20	UF4252	BHCS M10 -1.5x20mm	8
21	UPM6425	20MM X 12.5MM X 7MM SPACER	4
22	UPM1788EV	FLANGE BEARING BRONZE.375 X .75"	4
23	UPM1803	SPROCKET FIXED SHAFT	2
24	UPM6444	SPROCKET #35, T20 14mm BORE	2
25	UPM6437	TOP CHAIN ADAPTOR BRACKET	1
26	UF3679	HHCS M10-1.5 x 20 mm	4
27	UPM6443	SPRING FOR 20MM SHAFT	2
28	UPM6442	ANTI-COLLISION GASKET	2
29	UPM6440	LINK PLATE #1	1
30	UF3282	SS FHCS M5-0.8 x 12 mm	2
31	UF3391	SS NYLON LOCK NUT M6-1.0	2
32	UPM6435	LINK PLATE #2	1
33	UPM6451	CYLINDER UPPER MOUNT	1
34	UPM6448	250MM STROKE AIR CYLINDER	1
35	UPM6447	SPEED CONTROL JOINT	2
36	UF9150	20MM SPLIT COLLAR SHAFT	1
37	UPM6432	SPACER FOR ROLLER PLATE (LEFT)	2
38	UPM6439	MOUNTING PLATE	2
39	UPM6436	BOTTOM ROLLER PLATE	2
40	UF5402	FHCS M6-1 x 20	8
41	UPM6446	48MM ROLLER WHEEL	14

7.8 USM0881 – PNEUMATIC CONTROL ASSEMBLY

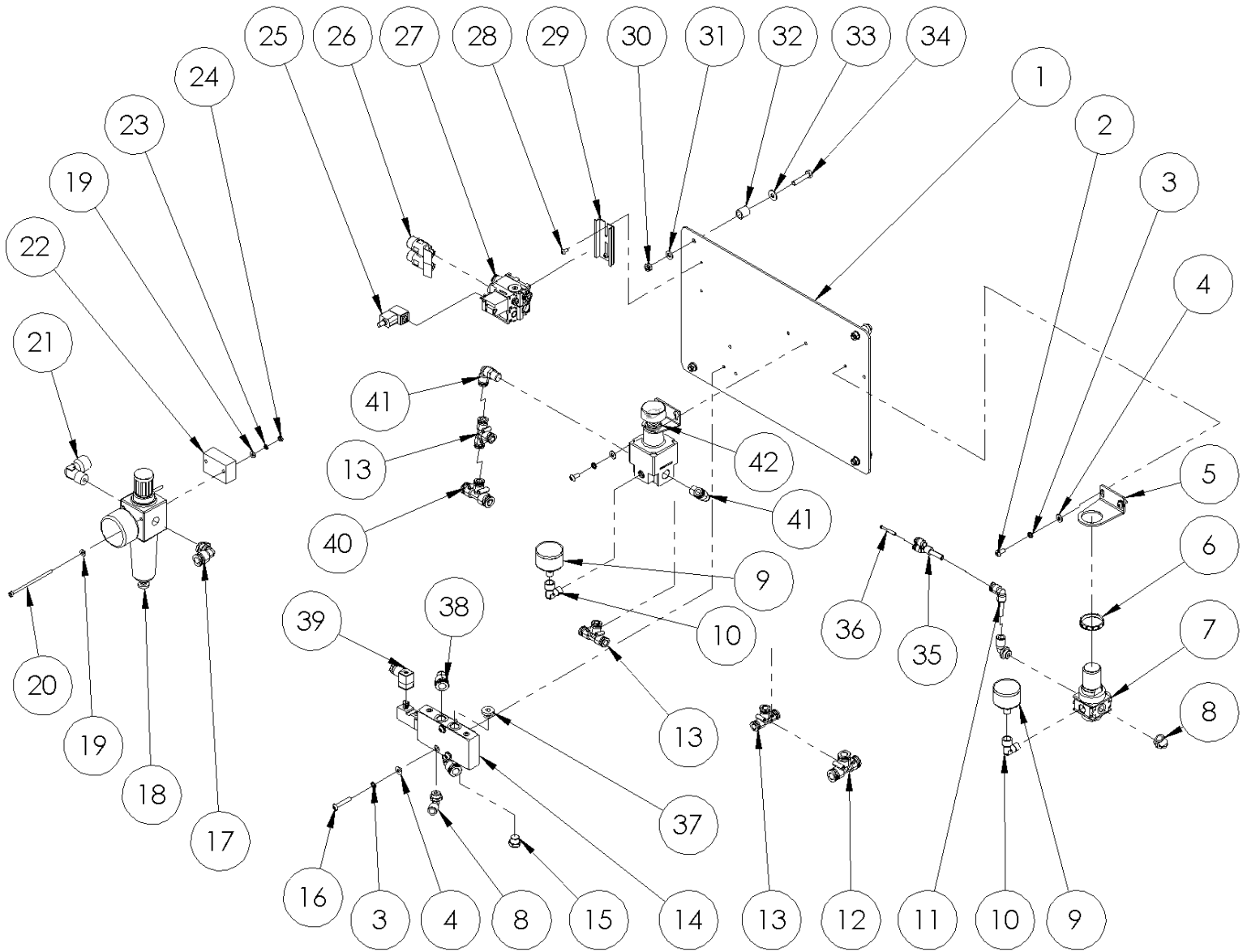

USM0881 – PNEUMATIC CONTROL ASSEMBLY

ITEM NO.	PART NUMBER	DESCRIPTION	QTY.
1	UPM6452	CONTROL SUPPORT PLATE	1
2	UF3687	BHCS M5-0.8 X 12MM	4
3	UF7023	M5 LW	7
4	UF1827	FW REG M5	7
5	UPM3271	MOUNTING BRACKET NL1	1
6	UPM3272	CONTROL PANEL NUT	1
7	UPM3268	PRESSURE REGULATOR MANIFOLD	1
8	UPM3124	ELBOW FTG.SWVL G1/4	4
9	UPM3273	PRESSURE GAUGE G1/8	2
10	UPM7736	ELBOW BRSS	2
11	UPM6463	90° REDUCING QUICK PLUG 5.5mm - 6mm	1
12	UPM6461	TEE QUICK CONNECTOR 10mm	1
13	UPM6460	TEE QUICK CONNECTOR 8mm	3
14	UPM4817	VALVE	1
15	UPM6171	SILENCER	1
16	UF3093	BHCS M5-0.8 X 30MM	3
17	UPM6466	90° QUICK CONNECTOR 10mm	1
18	UPM3267	FILTER REGULATOR NL2 G3/8 0.2 BAR	1
19	UF0115	FW M4, 10mm OD, 1mm THK	4
20	UF3694	SHCS M4-0.7 X 80	2
21	UPM3175	ELBOW BRSS NKL PLT G3/8M x G3/8F	1
22	UPM6453	FILTER REG. MOUNTING BRKT.	1
23	UF3681	M4 LW	2
24	UF4237	HEX NUT M4-0.7	2
25	UPM5981	WIRE CONNECTOR	1
26	UPM3391	SILENCER VALVE	2
27	UPM3394	VALVE 5/2 MAN. ADJUSTABLE 24V PE	1
28	UF3685	BHCS M4-0.7 X 8	2
29	UPM0407	DIN RAIL	2.5
30	UF5900	NYLON LOCK NUT M6-1.0	4
31	UF0127	FW M6-13-1.0	4
32	UPM7738	CONTROL SUPPORT PLATE SPACER	1
33	UF0126	FW M6-16-1.0	4
34	UF3689	HHCS M6-1.0 X 30	4
35	UPM6462	Y REDUCING QUICK PLUG 6mm-4mm	1
36	UPM6465	Ø4mm PLUG	1
37	UPM3133	PLUG G1/4"	1
38	UPM3124	ELBOW LVT G 1/4MALE X10MM TUBE	2
39	UPM6456	SOLENOID CONNECTOR	1
40	UPM6464	T REDUCING QUICK COUPLING 10mm-8mm	1
41	UPM6467	EXT. TOOTH 90° QUICK CONNECTOR	2
42	UPM6457	PRECISION PRESSURE REGULATOR	1