



USER MANUAL

USA 2324-TB



For Serial Numbers:
TM440 XX X XXX



OPERATION MANUAL

TABLE OF CONTENTS

OPERATION MANUAL	2
TABLE OF CONTENTS	2
REVISION CONTROL	3
TECHNICAL ASSISTANCE	4
<i>Technical Support</i>	<i>4</i>
<i>Replacement Parts</i>	<i>4</i>
WARRANTY	5
DESCRIPTION OF MACHINE	6
<i>Description</i>	<i>6</i>
IMPORTANT SAFEGUARDS	7
SPECIFICATIONS	10
<i>Machine Dimensions</i>	<i>10</i>
<i>Machine Weight</i>	<i>10</i>
<i>Power Requirements</i>	<i>11</i>
<i>Operating Speed</i>	<i>11</i>
<i>Operating Conditions</i>	<i>12</i>
<i>Tape Specifications</i>	<i>12</i>
<i>Carton Specifications</i>	<i>13</i>
SET-UP PROCEDURE	14
<i>Receiving and Handling</i>	<i>14</i>
<i>Set-Up</i>	<i>14</i>
OPERATING INSTRUCTIONS	16
MAINTENANCE	17
TROUBLESHOOTING	18
<i>Recommended Spare Parts</i>	<i>19</i>
OPTIONAL EQUIPMENT	20
PARTS LIST	21

Revision Control

REVISION CONTROL

REV00	Initial Release
REV01	Updated Release
REV02	Updated Release
REV03	Updated Release
REV04	Updated Release
REV05	Updated Release

TECHNICAL ASSISTANCE

Technical Support

This is the Interpack Model USA 2324-TB Uniform Top and Bottom Belt Case Sealer you ordered. It has been set up and tested in our factory with Intertape manufactured pressure sensitive tapes. If any problems occur when setting up or operating this equipment, please contact the authorized distributor from where you purchased this item.

Should you need to contact **Interpack Technical Support**, please have the Case Sealer **model number and serial number** available. This information can be found on the nameplate of the side panel of the machine. Interpack Technical Support is available during normal business hours (Eastern Time).

PHONE 813-621-8410 x101

If you have a technical question that does not require an immediate response, you may contact Interpack by fax.

FAX 813-621-8449

Replacement Parts

Order parts by item number, part name and quantity required. Replacement parts are available from your Authorized Interpack Distributor exclusively.

Should you require assistance selecting the correct part, you may call:

Intertape Polymer Group
Interpack Machinery
9940 Currie Davis Drive, Suite 23B
Tampa, FL, 33619

Tel: 1-800-474-8273 Option 3

Fax: 1-800-462-1293

MODEL:

SERIAL NUMBER:

DISTRIBUTOR PURCHASED FROM:

DATE OF PURCHASE:

WARRANTY

EQUIPMENT WARRANTY AND LIMITED REMEDY: The following warranty is made in lieu of all other warranties, express or implied, including, but not limited to, the implied warranty of merchantability, the implied warranty of fitness for a particular purpose, and any implied warranty arising out of a course of dealing, a custom or usage of trade:

Intertape sells its Interpack Tape Heads, Case Tapers and Case Erectors with the following warranties:

1. The HSD[®] 2000 Tape Heads' knife blades, springs and wipe down rollers will be free from all defects for a period of ninety (90) days.
2. All other HSD[®] 2000 Tape Head parts will be free from all defects for one (1) year after delivery.
3. Water Activated Tapers' blades and brushes will be free from defects for ninety (90) days after delivery
4. Drive Belts will be free from defects for ninety (90) days after delivery
5. The Gear Motors will be free from defects for one (1) year after delivery.
6. All other components for Case Tapers and Case Erectors will be free from defects for one (1) year after delivery.

If any part is proven defective within its warranty period, then the exclusive remedy and Intertape's and the seller's sole obligation shall be, at Intertape's option, to repair or replace the part, provided the defective part is returned immediately to Intertape's factory or an authorized service station designated by Intertape.

A part will be presumed to have become defective after its warranty period unless the part is received or Intertape is notified of the problem no later than five (5) calendar days after the warranty period.

If Intertape is unable to repair or replace the part within a reasonable time, then Intertape, at its option, will replace the equipment or refund the purchase price. Intertape shall have no obligation to install the repaired or replacement part.

Intertape shall have no obligation to provide or pay for the labor required to install the repaired or replacement part. Intertape shall have no obligation to repair or replace (1) those parts failing due to: operator misuse, carelessness, or due to any accidental cause other than equipment failure, or (2) parts

1. Failure or damage is due to misapplication, lack of proper maintenance, abuse, improper installation or abnormal conditions such as temperature, moisture, dirt or corrosive matter, etc.
2. Failure due to inadequate cleaning, improper operating environment, improper utilities or operator error.
3. Failure due to operations above the rated capacities, or in any other improper manner, either intentional or otherwise.
4. Failure is due to equipment, which has been altered by anyone other than an authorized representative of Intertape Polymer Group.
5. Failure is due to an attempt by the purchaser to correct alleged defective equipment. In this event the purchaser is responsible for all expenses incurred.

LIMITATION OF LIABILITY: Intertape and seller shall not be liable for direct, indirect, special, incidental or consequential damages based upon breach of warranty, breach of contract, negligence, strict liability or any other legal theory.

The foregoing Equipment Warranty and Limited Remedy and Limitation of Liability may be changed only by written agreement signed by authorized officers of Intertape and seller.

DESCRIPTION OF MACHINE

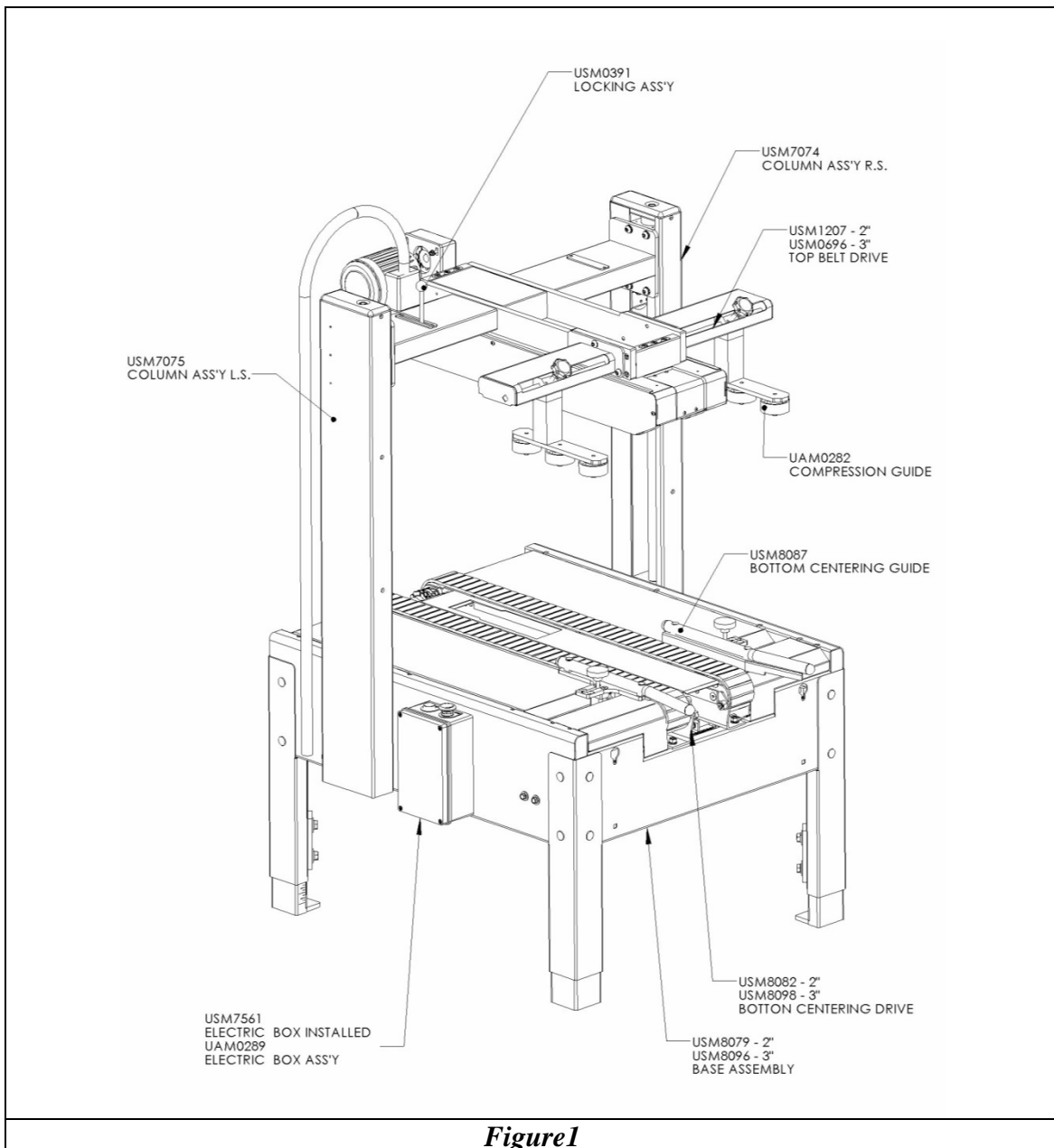



Figure 1

Description

The Intertape USA 2324 TB Top and Bottom Belt Drive Carton Sealing Machine with HSD2000 ET II Tape Heads is designed to apply Intertape brand Pressure Sensitive carton sealing tape to the top and bottom center seam of Regular Slotted Containers (RSC). The USA 2324 TB is manually adjustable to a wide range of carton sizes.

IMPORTANT SAFEGUARDS

There is a number of safety labels used on Intertape Carton Sealers.

<p>The illustrated label shown in Figure 2 is attached to the Knife Guard inside the upper and lower HSD2000 ET II Tape Head. The label warns operators and service personnel of the very sharp knife used to cut the tape at the end of the tape application.</p> <p>The HSD2000 ET II Tape Heads are equipped with a Knife guard that covers the blade. The Tape Heads should never be operated with the blade guards removed.</p> <p>Turn air and electrical supplies off before servicing the tape heads.</p>	 <p>! WARNING</p> <p>Sharp Cutting Blade</p>
<p><i>Figure 2</i></p>	

<p>The label shown in figure 3 is attached to the control box next to the on/off switch. The label warns the service personnel to unplug the power supply before attempting any service work on the carton sealer.</p>	 <p>! DANGER</p> <p>HAZARDOUS VOLTAGE</p> <p>Follow lockout procedures before servicing machine or electrical enclosures.</p> <p>Contact with live electrical parts will result in</p>
<p><i>Figure 3</i></p>	

The illustrated label shown in Figure 4 is located on the “Exit” end of the machine bottom belts. The label warns the operators and service personnel of the pinch point at the exit end of the bottom belts.



Figure 4

The illustrated label shown in Figure 5 is located on the “Exit” end of the machine top belts. The label warns the operators and service personnel of the pinch point at the exit end of the top belts.

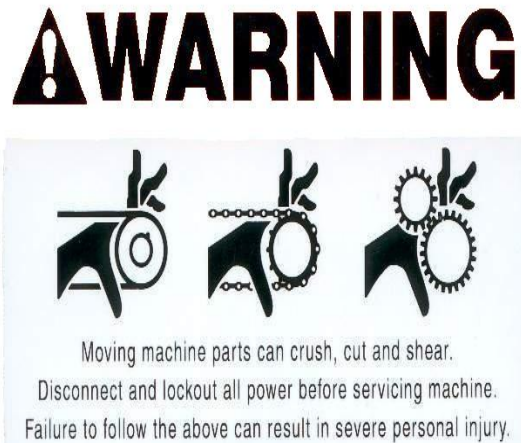

Figure 5

The illustrated label shown in Figure 6 is located on the side of the column. This label provides convenient safety instruction for the operator and service personnel in the operation of the Intertape Carton Sealing Equipment.

⚠ WARNING

OPERATION / SERVICE

- Only trained people are to operate and service machine.
- Shut off power to machine before adjusting.
- Unplug electrical power before servicing.

MACHINE MANUAL

For other important safety, operating and service information read this machine's manual.

EYE HAZARD

Wear Safety Glasses which conform to ANSI Std. Z87.1 or EN 166



COVERS AND GUARDS

All covers and guards must be in place before operating machine.

ELECTRICAL SHOCK

Hazardous voltages may cause personal injury.



Only authorized and qualified personnel are to service electrical enclosures.

FAILURE TO FOLLOW THE ABOVE COULD RESULT IN SEVERE INJURY.

Figure 6

Note: Should any of the safety labels placed on the Machine be damaged or destroyed, replacements are available.

SPECIFICATIONS

Machine Dimensions

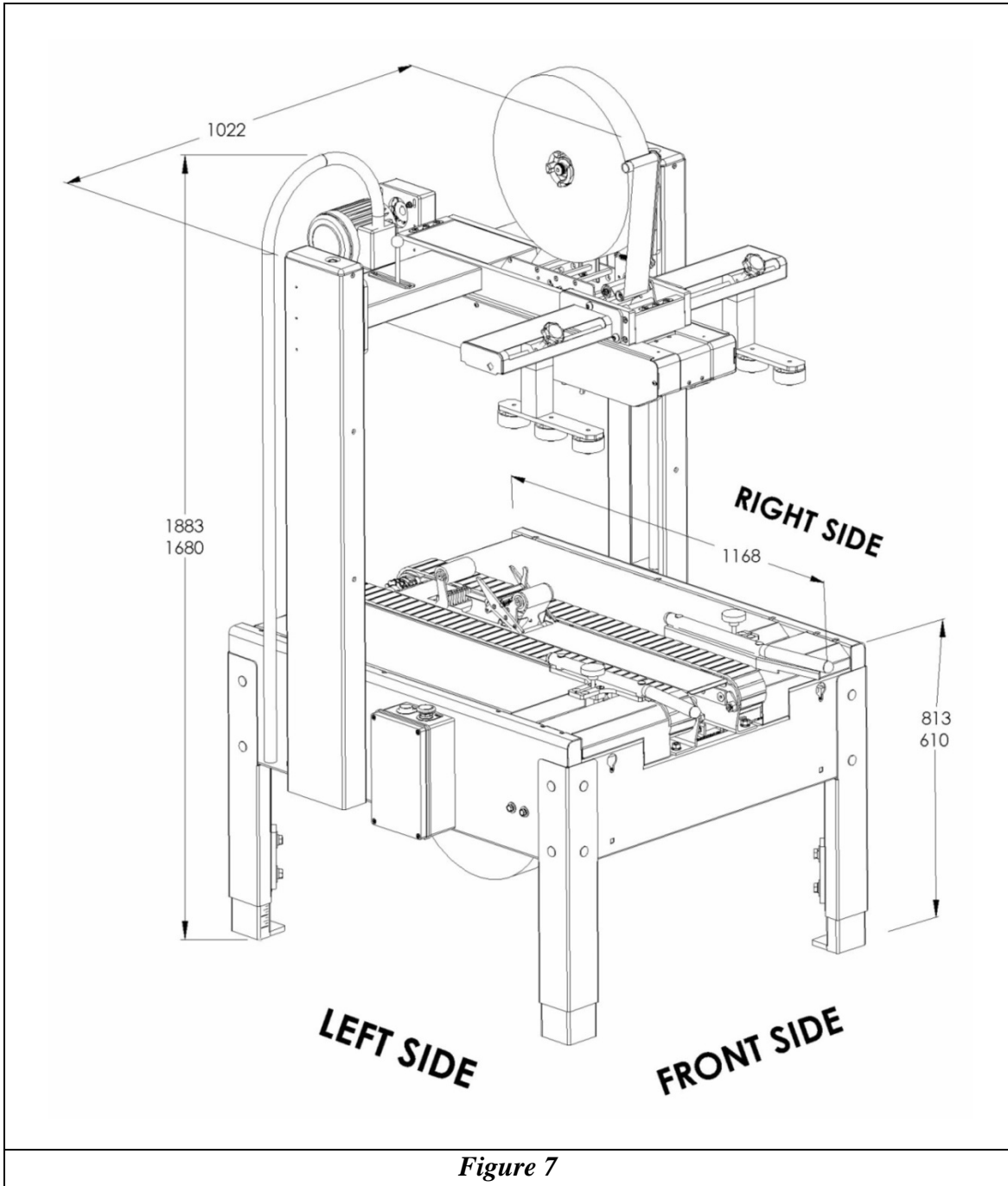

Machine Weight : 630 lbs. (286 kg)

Power Requirements

Electrical – 110v, 60 HZ, 6 A (400 Watts)

This machine comes standard with a bottom gear motor, a top gear motor and an electrical box.

The electrical box contains a Start switch, the Emergency Stop switch, and a Starting Relay with a thermal over load and can be located on either side of the carton sealer for customer convenience (specify with order). A six (6) foot standard three conductor power cord with plug is provided for **110V, 60HZ, 15 Amp** service. The receptacle providing this service must be properly grounded. Before the machine is plugged into the receptacle, ensure that the switch is **OFF** and all materials are removed from the machine.

Operating Speed

Actual production rate is dependent on operator's dexterity and the case size mix. Boxes must be 6 inches apart.

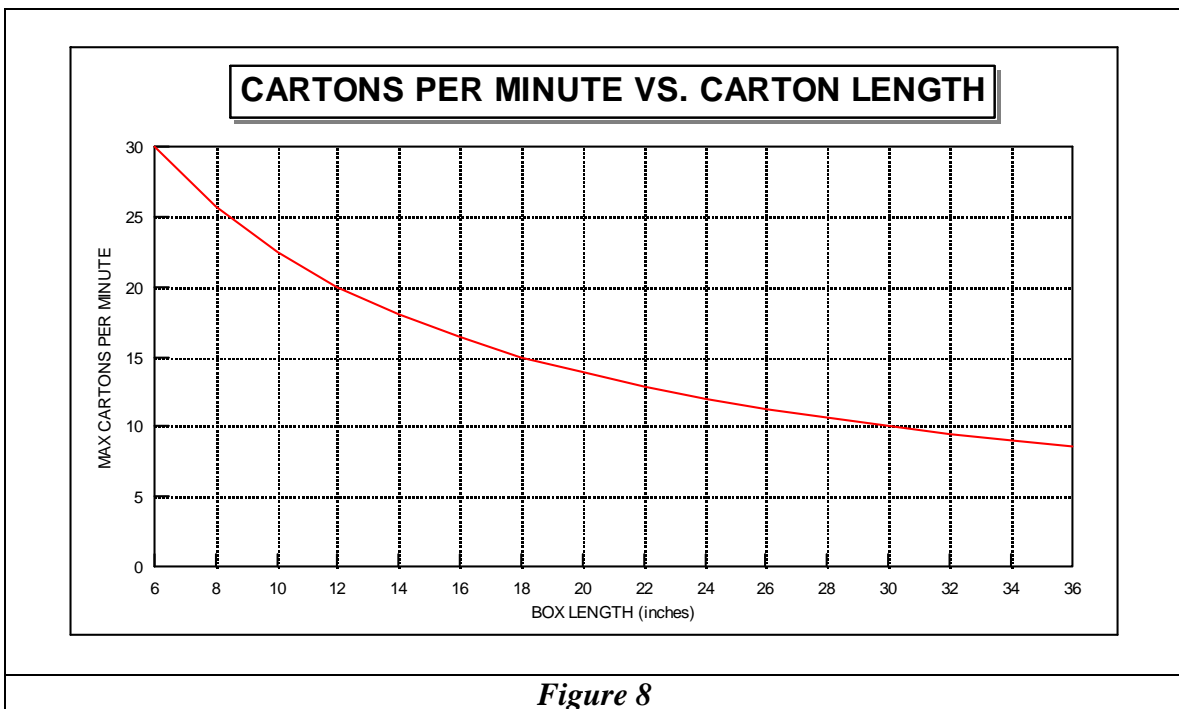

Operating Conditions

Use in a dry, relatively clean environment at 40° to 105° F (5° to 40° C) with clean dry cartons.

Note: Machine should not be washed down or subjected to conditions causing condensation on components.

Tape Specifications

Use **Intertape Brand** Pressure Sensitive Carton Sealing Tape.

The machine can accommodate 2 (48mm) or 3 inch (75mm) wide tape, depending on tape heads supplied.

A maximum tape roll diameter of 16 inches (405 mm) on a 3-inch (76.2 mm) diameter core can be installed on the tape head. (Accommodates all Intertape brand film tape machine roll lengths).

The standard Application Leg Length of 2.5 inches (+0.25", -0") (63.5 mm, +6.3 mm, -0 mm) is the factory set length. The tape head can be adjusted to an optional length of 2 inches (+0.25", -0") (50.8 mm, +6.3 mm, -0 mm). Refer to the Tape Head manual for adjustment of tape application leg length.

Note: For further specifications on the tape heads consult the tape head manual for your specific tape head.

Carton Specifications

Type

Regular Slotted Containers (RSC)

Material

125 to 275 PSI bursting test, single or double wall B or C flutes.

Weight

0 to 85 lbs. (0 to 38.5 kg)

Size

The carton sealer can accommodate most cartons within the size ranges listed bellow.

2" TAPE HEAD			
Carton Size	Length	Width	Height
Minimum	7" (127mm) 9 ½" (241.3mm) opt.	7" (127mm) 9 ½" (241.3mm) opt.	2" (51mm)
Maximum	Infinite (Infinite)	23" (584mm) 26 ½" (673.1mm) opt.	24" (610mm)

3" TAPE HEAD			
Carton Size	Length	Width	Height
Minimum	7" (127mm) 9 ½" (241.3mm) opt.	7" (127mm) 9 ½" (241.3mm) opt.	2" (51mm)
Maximum	Infinite (Infinite)	23" (584mm) 26 ½" (673.1mm) opt.	24" (610mm)

However, if the box length (in direction of seal) to box height ratio is .75 or less, than several boxes should be test run to assure proper machine performance. The formula is as follows;

$$\frac{\text{CARTON LENGTH IN DIRECTION OF SEAL}}{\text{CARTON HEIGHT}} > .75$$

SET-UP PROCEDURE

Receiving and Handling

The machine is shipped to the customer in a box and fixed to a pallet.

- Remove the strapping and the staples at the bottom of the box.
- Lift off the box cover and sleeve.
- Remove the mounting bolts and nuts, which secure the USA 2324-TB to the shipping pallet.
- Lift the machine off the pallet and install it in your packaging line.
- Remove all tie wraps and other shipping materials.

Note: After unpacking the machine, look for any damage that may have occurred during shipping. Should the machine be damaged, file a claim with the transport company and notify your Intertape representative as soon as possible.

Set-Up

The Carton Sealer must be installed on a near level ground. Use the adjustable legs to ensure that the machine is level and firmly on the ground (no rocking). Adjust the leg height with the four (4) telescopic adjustment legs to accommodate conveyor heights from 24 to 30 inches.

To adjust the Carton Sealer height, jack up the machine to give ample room to extend the legs. Using a 19 mm box end wrench, loosen the eight (8) 12mm hex. head bolts. Adjust the legs to the desired conveyor height and tighten the bolts. Etched lines on the legs ease leveling.

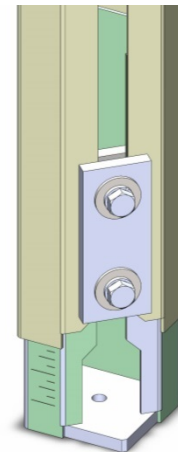

Figure 9

Customer supplied feed conveyor (if used) should provide straight and level entry into the carton sealer. Customer supplied exit conveyor (if used) should be straight and declined no more than 20mm/meter away from the machine to convey the sealed cartons away from the machine.

To avoid shipping damage, we have removed the bottom centering rails from the machine. You will find them on the pallet wrapped separately. Please install them with the included screws as shown in figure 10.

- 1.) Hole Cover
- 2.) M8 Screw
- 3.) Guide Rail
- 4.) Tube Seat
- 5.) Mounting Arm

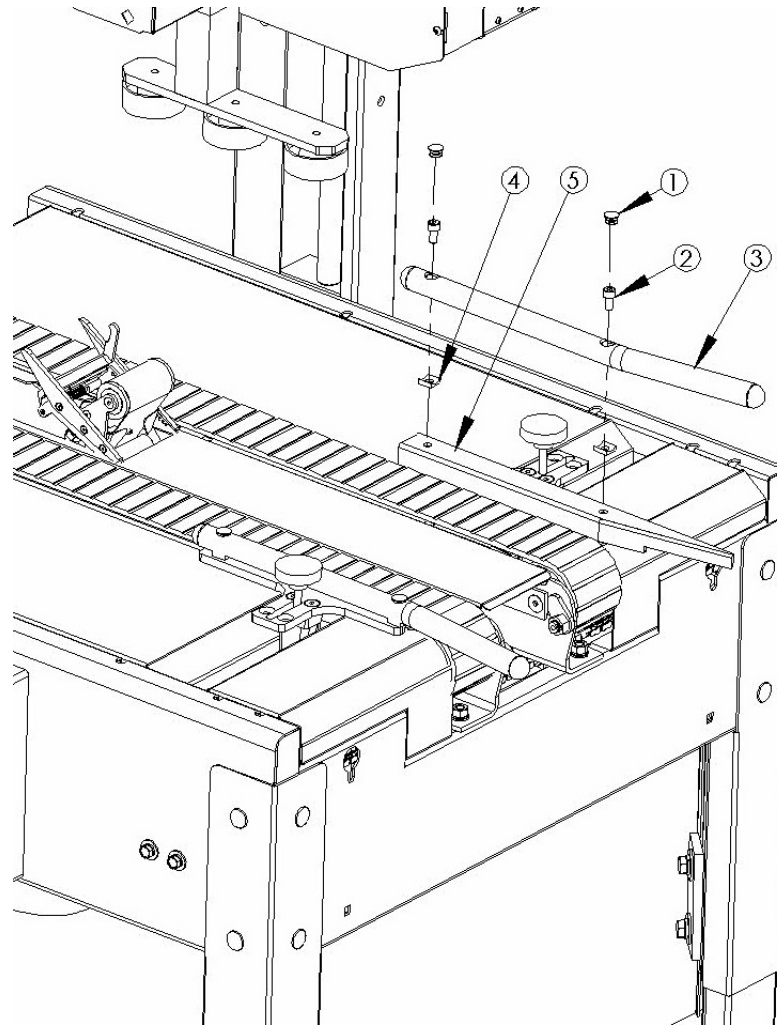

Figure 10

Plug the power cord into an appropriate receptacle.

OPERATING INSTRUCTIONS

Once the Tape Heads, (both bottom and top) have been loaded with tape and threaded (refer to the appropriate Tape Head manual for loading and threading instructions) the machine is ready to process RSC cartons. The following instructions are presented in **the order recommended** for processing cartons successfully through the USA 2324 TB Carton Sealing machine.

- 1- Loosen the Arching Side Guide locking handle and open the Arching Side Guides completely (Push to outside of machine).
- 2- Loosen locking handle on the Top Tape Head Assembly and raise it until it clears the new carton.
- 3- Place a new carton between the Side Guides under the Top Tape Head Assembly, and close against carton under moderate pressure. (DO NOT CRUSH CARTON)
- 4- Lower the Top Tape Head Assembly until it rests on the carton and tighten the locking handle.
- 5- Loosen the Top Compression Guides locking handles (x2) and close against the carton enough to keep the slot in the center closed while taping and tighten the locking handles to secure the guides against the carton.
- 6- Remove the carton.
- 7- Check to insure all personnel are clear.
- 8- Release the E-stop switch and start the machine with the green start button.
- 9- Feed the closed carton to the machine.

WARNING: Ensure that the operator's hands are away from the contact area between the Top Tape Head Box and the carton.

MAINTENANCE

The USA 2324-TB carton sealer has been designed for trouble-free service. The machine will perform best when it receives routine cleaning and maintenance.

Warning! Turn off electrical power and **lock out** the electrical supply before beginning cleaning or maintenance. If power cords are not disconnected, severe injury to personnel could result.

Lubrication

Spray column shafts, centering guide shafts and compression guide shafts once a month with silicon based dry film lubricant. This won't attract dust or lint from the surroundings.

Apply chain lube on the drive and centering guide chain once a month.

No other lubrication is necessary to operate the machine.

Cleaning

Cartons produce a sizable amount of dust and paper chips when processed or handled. If this dust is allowed to build up in the machine, it may cause component wear and overheating of motors. Remove the accumulated dust with a shop vacuum. Avoid using compressed air to remove the dust as this may cause the dust to penetrate into parts.

TROUBLESHOOTING

Interpack Machinery Carton Sealers are fabricated with high quality components that provide trouble-free operation for a long period of time. However, if a problem should occur we recommend that you always look for simple things first, then more complex problems. This is exactly how this table is constructed, as the numbers increase, complexity increases.

TROUBLE	POSSIBLE CAUSES	SOLUTIONS
The machine is turned on and nothing happens	1- The starter overload or the circuit breaker is tripped. 2- Machine is unplugged	1- Wait a few minutes for the thermal overload to reset or reset circuit breaker. Check proper amperage and voltage at power connection.
The Top Tape Head Box marks the cartons.	1- The Top Tape Head Box Assembly is too low.	1- Adjust the height of the Top Tape Head Box Assembly.
The Drive Belts are sliding on the carton.	1- The pressure between the Top Tape Head Box and the carton is not sufficient.	1- Lower the Top Tape Head Box onto the carton.
The cartons are not taped properly.	1- The tape head is not adjusted correctly	1- Refer to the Tape Head manual.

RECOMMENDED SPARE PARTS

DESCRIPTION	ITEM NUMBER	RECOMMENDED QTY.
BEARING PULLEY	UPM0324	2
BELT, DRV SAG12E 75MM X 2136LG	UPM7468	2
BELT, DRV SAG12E 50MM X 1915LG	UPM7657	2
FLANGED BEARING 3/4 ID	UPM0339	2
LINEAR BEARING 25MM SHAFT	LM25UU	2
CONSTANT FORCE SPRING 33LBS	UPM0740	3
WHEEL 2-7/8" DIA. COMPRESSION GUIDE	UPM1659	3
SINGLE LOCKING HANDLE	UPM0688EV	1

OPTIONAL EQUIPMENT

Model Number	Description	Item Number	Quantity Per Machine
USA 2324 TB	Feed/Exit Table 16" (.4 M)	UM894T	1 or 2
	Feed/Exit Table 24" (.6 M)	UM998T	1 or 2
	Feed/Exit Table 36" (.9 M)	UM898T	1 or 2
	Heavy Duty Casters	UM841	1 set of 4
	Secondary E-Stop	UM9003	1
	Carton Hold Down Device	UM897	1

APPENDIX - ILLUSTRATIONS AND PARTS LISTS

UM440TW

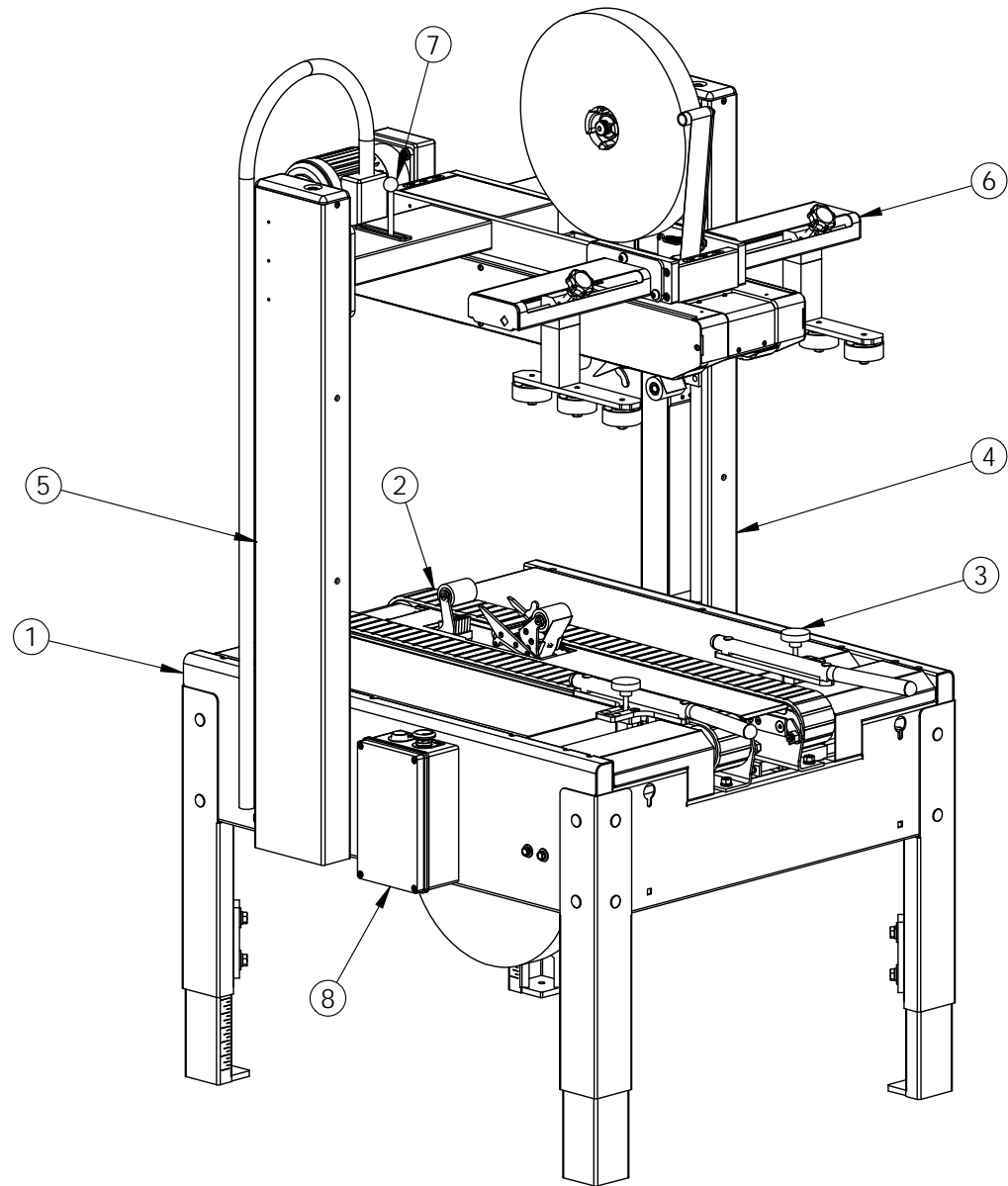

UM440TW

ITEM NO.	PART NUMBER	DESCRIPTION	QTY.
1	USM8096	BASE USA2324 3"	1
2	USM8098	BB DRIVE USA2324 3"	1
3	USM8087	BOTTOM CENTRING GUIDE	1
4	USM7074	COLUMN TBD 24 RIGHT	1
5	USM7075	COLUMN TBD 24 LEFT	1
6	USM0820	TBD ASSEMBLY USA2324 3"	1
7	USM0391	SINGLE LOCK.ASS'Y	1
8	USM7561	ELECTRIC ASSEMBLY	1

USM8096

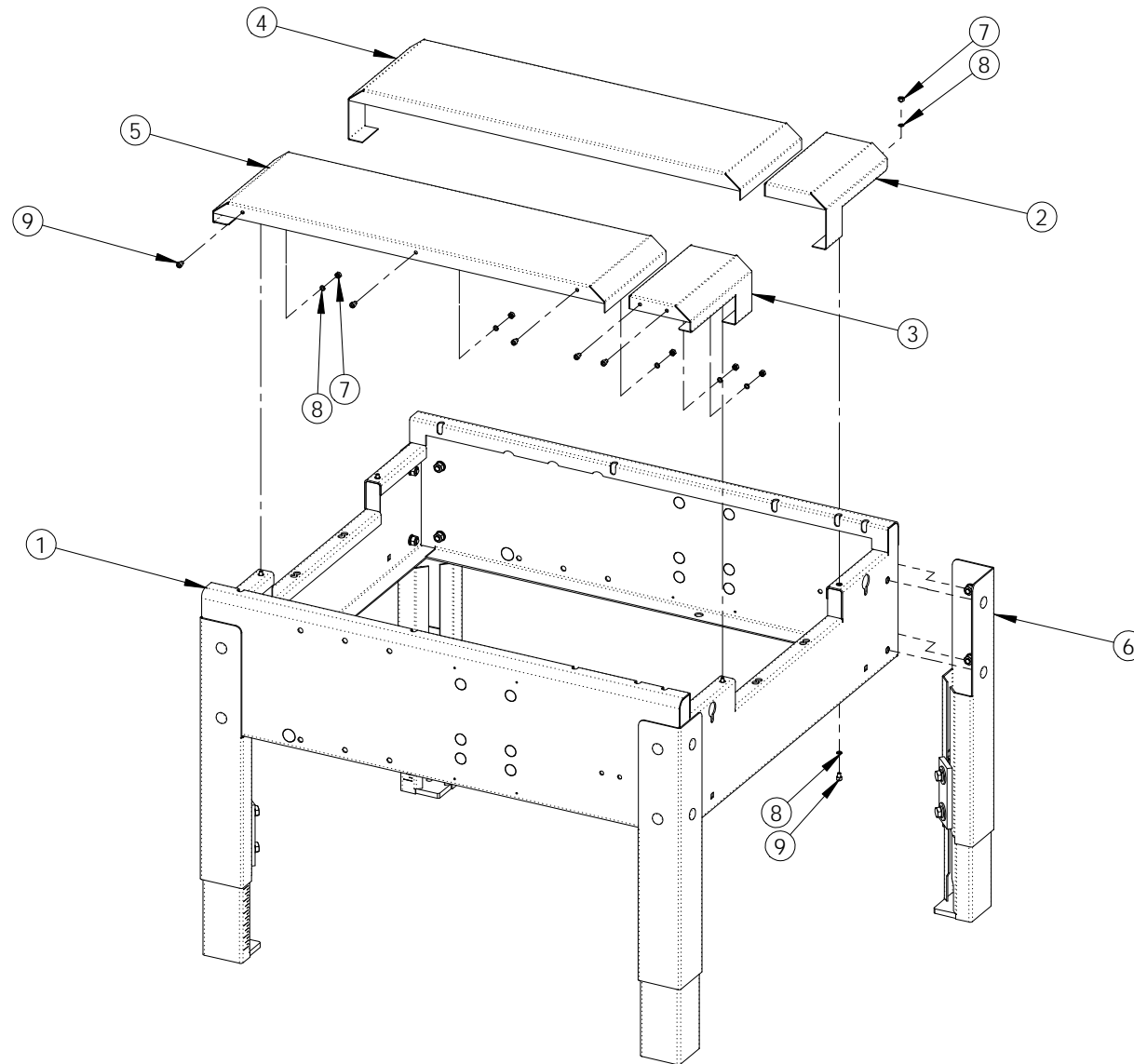

USM8096

ITEM NO.	PART NUMBER	DESCRIPTION	QTY.
1	UPM7394	BASE FRAME	1
2	UPM7545	FRONT COVER RIGHT SIDE 3"	1
3	UPM7544	FRONT COVER LEFT SIDE 3"	1
4	UPM7542	REAR COVER RIGHT SIDE 3"	1
5	UPM7543	REAR COVER LEFT SIDE 3"	1
6	UAM0275	LEG ASSEMBLY METRIC	4
7	UF3637	HNR M6-1.0	14
8	UF6363	LW M6	28
9	UF0810	SHCS M6-1 x 8	14

UAM0275

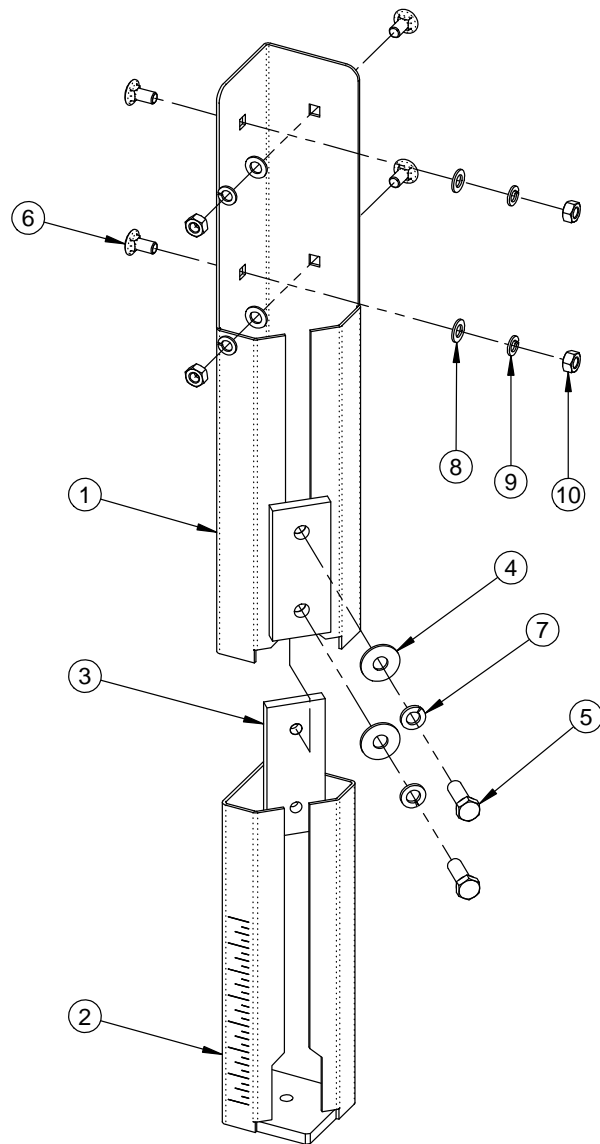

UAM0275

ITEM	PART #	DESCRIPTION	QTY.
1	UPM7640	LEG WELDMENT	1
2	UPM7641	LEG ADJUSTMENT	1
3	UPM7642	LEG FRICTION PLATE	1
4	UF4231	FW M12	2
5	UF6393	HHCSM12-1.75 x 35mm	2
6	UF4229	CARRIAGE BOLT M10-1.5 x 20	4
7	UF4230	L.W. ZINC M12	2
8	UF3680	FW M10	4
9	UF6371	LW M10	4
10	UF6314	HNR M10 x 1.5	4

USM8098

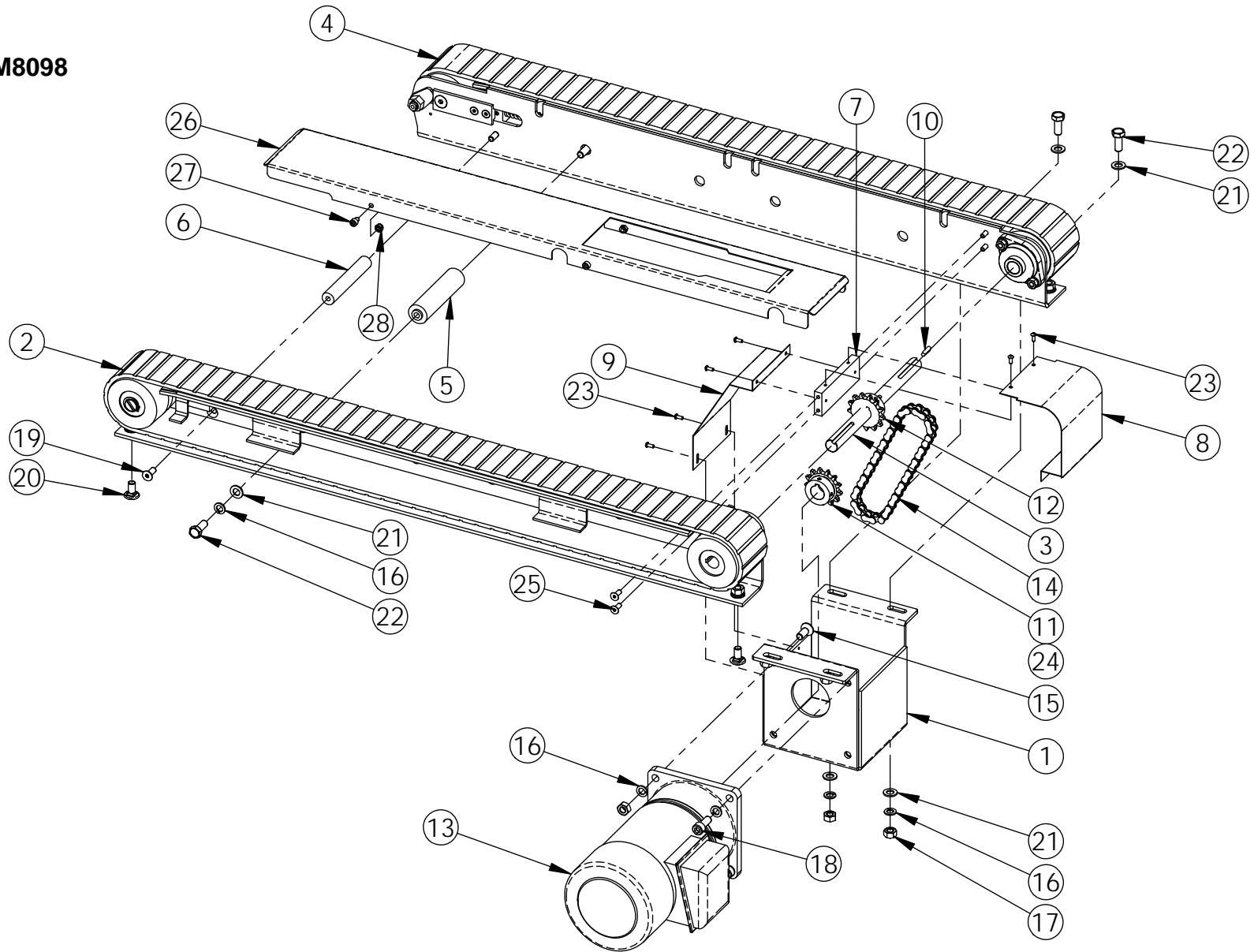

USM8098

ITEM NO.	PART NUMBER	DESCRIPTION	QTY.
1	UPM7546	MOTOR MOUNT, BRACKET 3"V	1
2	UAM0339	BB DRIVE LH USA2324	1
3	UPM4071	DRIVE SHAFT	1
4	UAM0340	BB DRIVE RH USA2324	1
5	UPM7552	SPACER, DRIVE 3"	1
6	UPM7554	SPACER 3" DRIVE 19 DIA	1
7	UPM7550	SPACER BAR	1
8	UPM7549	BACK CHAIN GUARD	1
9	UPM7548	FRONT CHAIN GUARD	1
10	UF2210EV	SQUARE KEY ROUND ENDS 5 X 5 X 20	1
11	UPM7517	SPROCKET 40B12 22MM - 7MM K/W	1
12	UPM7519	SPROCKET 40B12 19MM - 5MM K/W	1
13	UPM7516	MOTOR, LI-MING 1/2HP 1/20RAT	1
14	UPM4421	CHAIN 40 - 37 PITCH + C.L. + O.L	1
15	UF1191	FHCS M10-1.5 x 25	1
16	UF6371	LW M10	14
17	UF6314	HNR M10 x 1.5	9
18	UF0868	SHCS M10-1.5 x 25	3
19	UF1190	M8 - 1.25 x 20 FHCS	2
20	UF4229	CARRIAGE BOLT M10-1.5 x 20	4
21	UF3680	FW M10	14
22	UF6382	HHCS M10-1.5 x 25 mm	6
23	UF6365	BHCS M4 x 0.7 x 10mm	6
24	UF1411	SSS M6 X 6mm	4
25	UF1192	FHCS M6-1 x 16 mm	4
26	UPM7761	BOTTOM GAP FILLER	1
27	UF0810	SHCS M6-1 x 8	4
28	UF5900	NYLON LOCK NUT M6-1.0	4

UAM0339

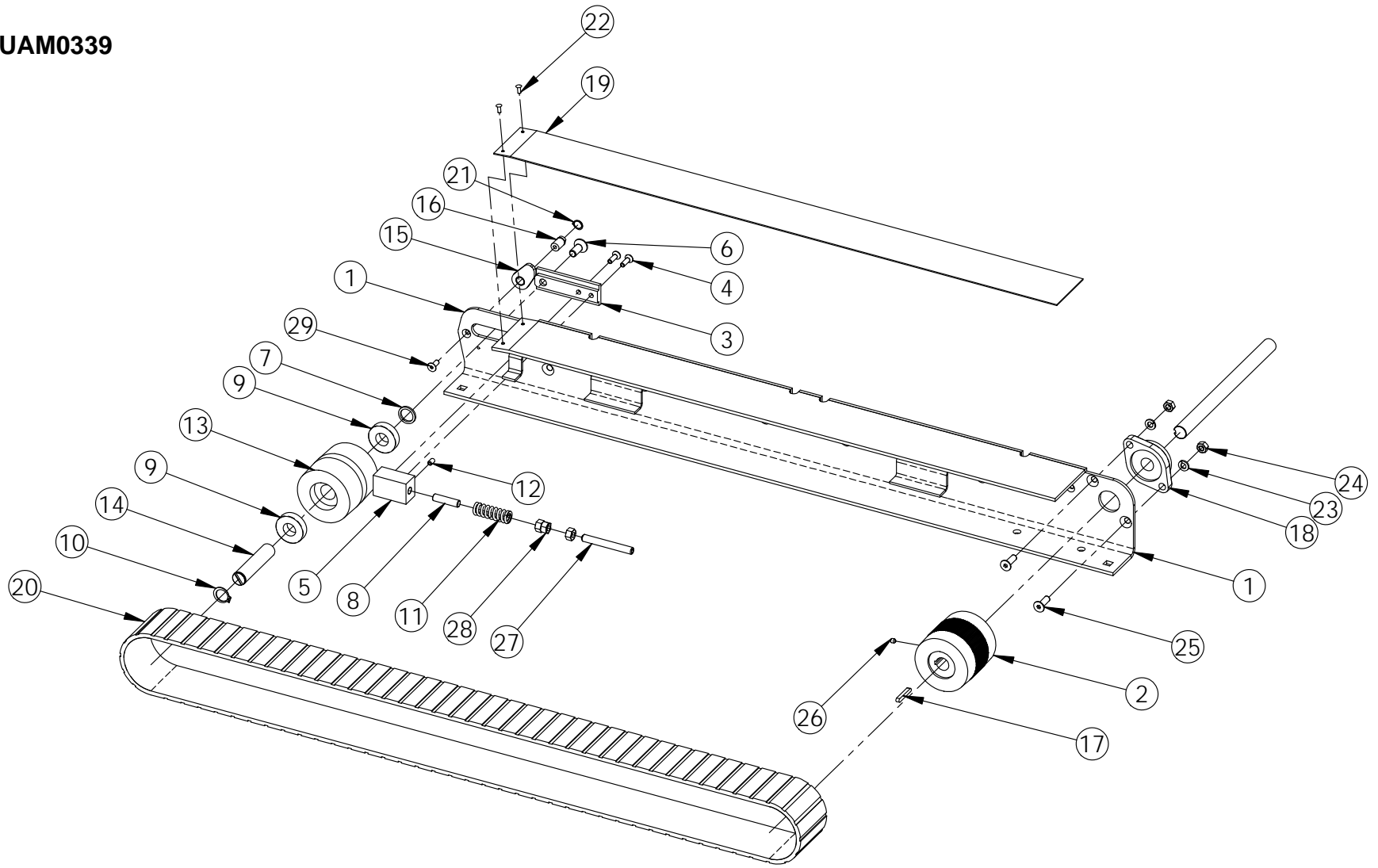

UAM0339

ITEM NO.	PART NUMBER	DESCRIPTION	QTY.
1	UPM4066	FRAME RH DRIVE	1
2	UPM4069	DRIVE PULLEY	1
3	UPM6074	TENSIONNER SLIDE	1
4	UF5402	FHCS M6 - 1 x 20	2
5	UPM0101EV	TENSIONNER SPRING HOLDER	1
6	UF1191	FHCS M10-1.5 x 25	1
7	UPM0109	IDLER PULLEY SPACER	1
8	UPM0112	SPRING LOCATOR PIN	1
9	UPM0324	BEARING, PULLEY	2
10	UF2220	EXT RET'G RING 3/4" SHAFT	1
11	UPM0038	DIE SPRING - LHL-750B-5	1
12	UF3683	SOCKET SET SCREW M6 x 10	1
13	UPM4070	IDLER PULLEY	1
14	UPM4072	IDLER SHAFT	1
15	UPM4076	SPRING COMP TOOL R.H.	1
16	UPM4078	SHAFT	1
17	UF6386EV	SQUARE KEY ROUND ENDS 5 X 5 X 35	1
18	UPM0339	FLANGE BEARING 3/4" ID	1
19	UPM7467	STRIP,UHMW,3"x.03	1
20	UPM7468	BELT DRIVE. SAG 12E, 75mm X 2136 LG	1
21	UF6300	Ret'g Ring External 12mm	1
22	UF3691	Pop Rivet 4mm	2
23	UF0867	LW M8	2
24	UF0866	HNR M8 - 1.25	2
25	UF6370	M8 - 1.25 x 25 FHCS	2
26	UF1411	SSS M6 X 6mm	1
27	UF1400	SSS HK 3/8-16 X 3	1
28	UF1540	HNR 3/8-16	3
29	UF1192	FHCS M6-1 x 16 mm	1

UAM0340

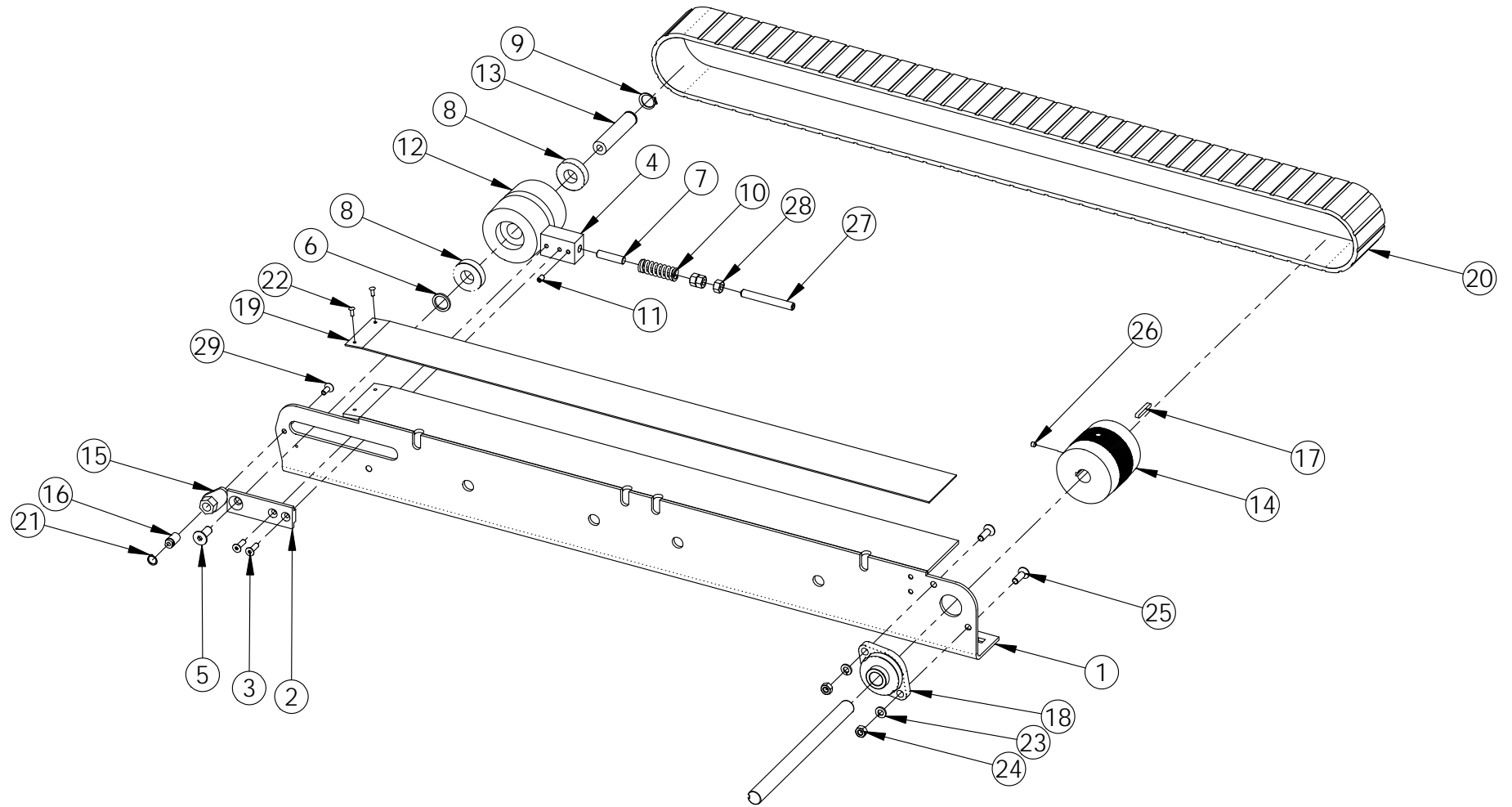

UAM0340

ITEM NO.	PART NUMBER	DESCRIPTION	QTY.
1	UPM4067	FRAME LH DRIVE	1
2	UPM6074	TENSIONNER SLIDE	1
3	UF5402	FHCS M6 - 1 x 20	2
4	UPM0101EV	TENSIONNER SPRING HOLDER	1
5	UF1191	FHCS M10-1.5 x 25	1
6	UPM0109	IDLER PULLEY SPACER	1
7	UPM0112	SPRING LOCATOR PIN	1
8	UPM0324	BEARING, PULLEY	2
9	UF2220	EXT RET'G RING 3/4" SHAFT	1
10	UPM0038	DIE SPRING - LHL-750B-5	1
11	UF3683	SOCKET SET SCREW M6 x 10	1
12	UPM4070	IDLER PULLEY	1
13	UPM4072	IDLER SHAFT	1
14	UPM4069	DRIVE PULLEY	1
15	UPM4077	SPRING COMP TOOL L.H.	1
16	UPM4078	SHAFT	1
17	UF6386EV	SQUARE KEY ROUND ENDS 5 X 5 X 35	1
18	UPM0339	FLANGE BEARING 3/4" ID	1
19	UPM7467	STRIP,UHMW,3"x.03	1
20	UPM7468	BELT DRIVE. SAG 12E, 75mm X 2136 LG	1
21	UF6300	Ret'g Ring External 12mm	1
22	UF3691	Pop Rivet 4mm	2
23	UF0867	LW M8	2
24	UF0866	HNR M8 - 1.25	2
25	UF6370	M8 - 1.25 x 25 FHCS	2
26	UF1411	SSS M6 X 6mm	1
27	UF1400	SSS HK 3/8-16 X 3	1
28	UF1540	HNR 3/8-16	3
29	UF1192	FHCS M6-1 x 16 mm	1

USM8087

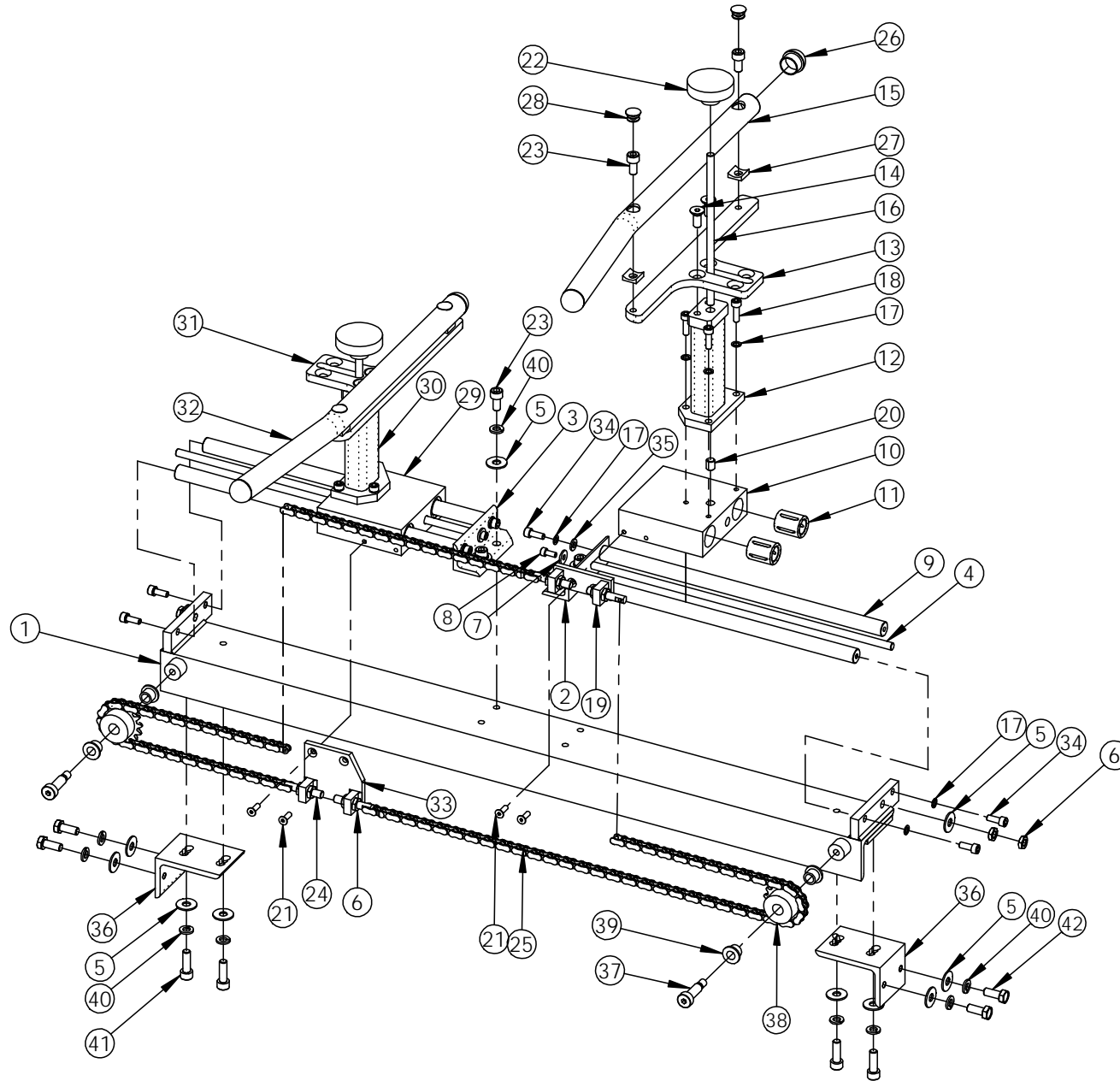

USM8087

ITEM	PART #	DESCRIPTION	QTY.
1	UPM4053	COMPRESSION GUIDE FRAME	1
2	UPM4057	SHAFT SUPPORT R.H.	1
3	UPM4062	SHAFT SUPPORT L.H.	1
4	UPM7479	BAR	2
5	UF1821	FW M8	14
6	UF6369	HEX JAM NUT M8 - 1.25	12
7	UF1827	FW M5	2
8	UF9154	SHCS M5-0.8 X 12	2
9	UPM7478	SHAFT 16mm X 340.93 lg	4
10	UPM4054	BEARING HOUSING R.H.	1
11	UPM7486	LINEAR BALL BEARING 16mm SHAFT	8
12	UPM7480	BRACKET R.H.	1
13	UPM4058	BOX GUIDE R.H.	1
14	UF1190	M8 - 1.25 x 20 FHCS	4
15	UPM4060	GUIDE ADAPTER R.H.	1
16	UPM4065	LOCKING SCREW	2
17	UF6363	LW M6	14
18	UF0835	SHCS M6-1 X 20mm	6
19	UPM7476	CHAIN BRACKET WITH TAKE-UP	1
20	UPM7475	LOCK, GUIDE	2
21	UF5404	FHCS M5 - 0.8 x 16 mm	4

ITEM	PART #	DESCRIPTION	QTY.
22	UPM4083	FLUTED KNOB	2
23	UF6367	SHCS M8-1.25 x 16	7
24	UPM7183	TAKE-UP SCREW	4
25	UPM7484	CHAIN #35, 80 LINK + C.L + O.L.	2
26	UPM7482	TUBE PLUG	4
27	UPM7521	CONCAVE SEAT	4
28	UPM7523	HOLE COVER CAP	4
29	UPM4055	BEARING HOUSING L.H.	1
30	UPM7481	BRACKET L.H.	1
31	UPM4059	BOX GUIDE L.H.	1
32	UPM4061	GUIDE ADAPTER L.H.	1
33	UPM7477	CHAIN BRACKET WITH TAKE UP	1
34	UF0830	SHCS M6-1 x 16 mm	8
35	UF1828	REG F.W. M6	4
36	UPM4064	MOUNTING ANGLE	2
37	UF6368	SHOULDER SCREW 10mm x 25, M8-1.25	2
38	UPM4084	SPROCKET # 35 B 15, 14mm BORE	2
39	UPM1781EV	FLANGED BEARING 10mm x 11.5mm	4
40	UF0867	LW M8	12
41	UF0865	SHCS M8-1.25 X 25mm	4
42	UF6309	HHCS M8-1.25 X 20MM	4

USM7074

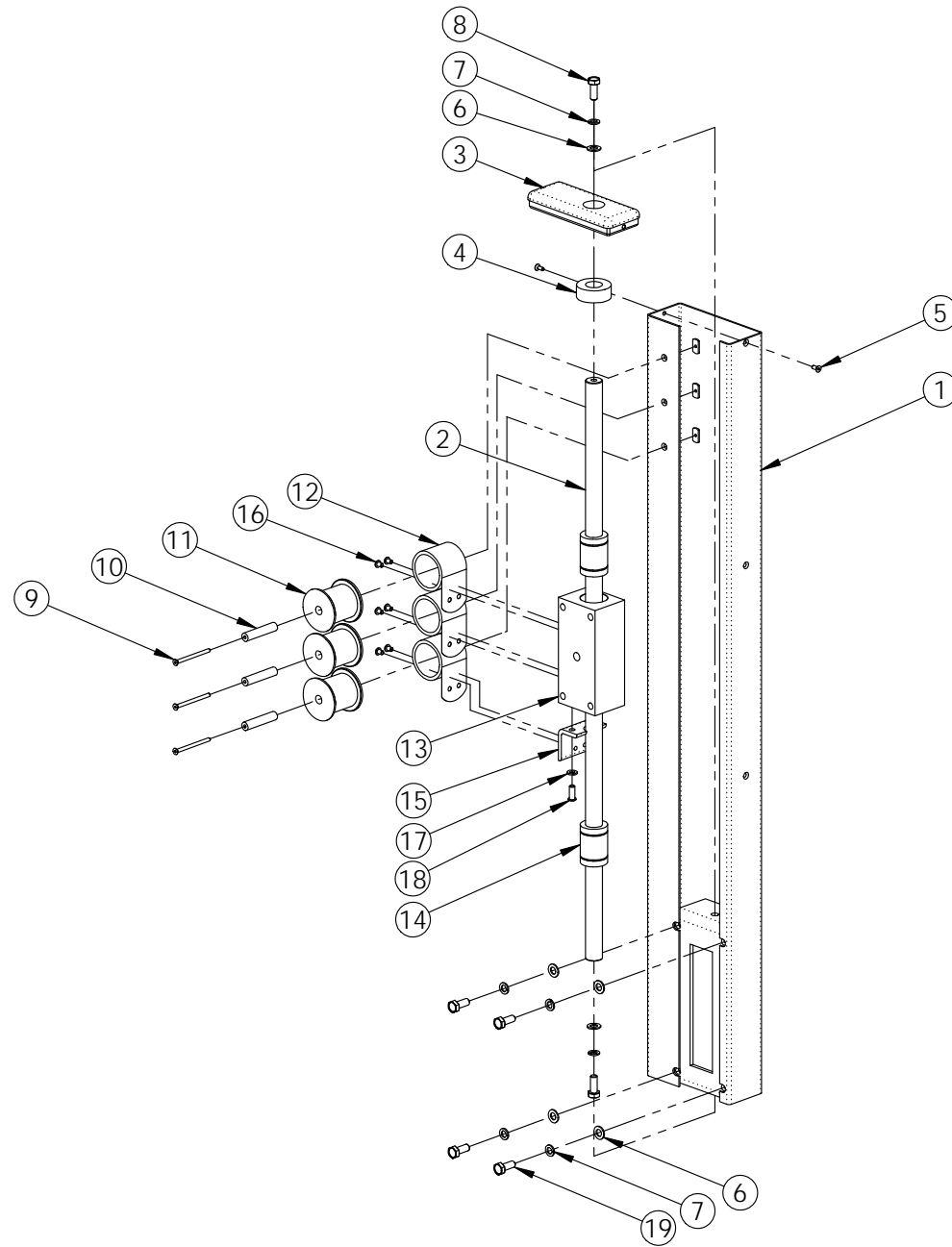

USM7074

ITEM	PART #	DESCRIPTION	QTY.
1	UPM7687	COLUMN 24 TBD RIGHT SIDE	1
2	UPM7688	COLUMN SHAFT	1
3	UPM2182EV	COLUMN CAP RIGHT SIDE	1
4	UPM2251	SAFETY BUMPER	1
5	UF5400	FHCS M5-0.8 x 12 mm	2
6	UF3680	FW M10	6
7	UF6371	LW M10	6
8	UF6383	SS HHCS M10-1.5 x 25 mm	2
9	UF1157	FHCS M5-0.8 x 70	3
10	UPM0743	SPRING MANDREL SHAFT	3
11	UPM0742	SPRING SPOOL	3
12	UPM0740	CONSTANT FORCE SPRING 33 lbs	3
13	UPM0735EV	COLUMN BLOCK RIGHT SIDE	1
14	LM 25UU	LINEAR BEARING 25 mm	2
15	UPM3731EV	3RD SPRING ANCHOR RIGHT SIDE	1
16	UF1206	BHCS M6-1 X 8mm	6
17	UF0867	LW M8	2
18	UF1318	BHCS M8-1.25 x 20 mm	2
19	UF3647	HHCS M10-1.25 x 25 mm	4

USM7075

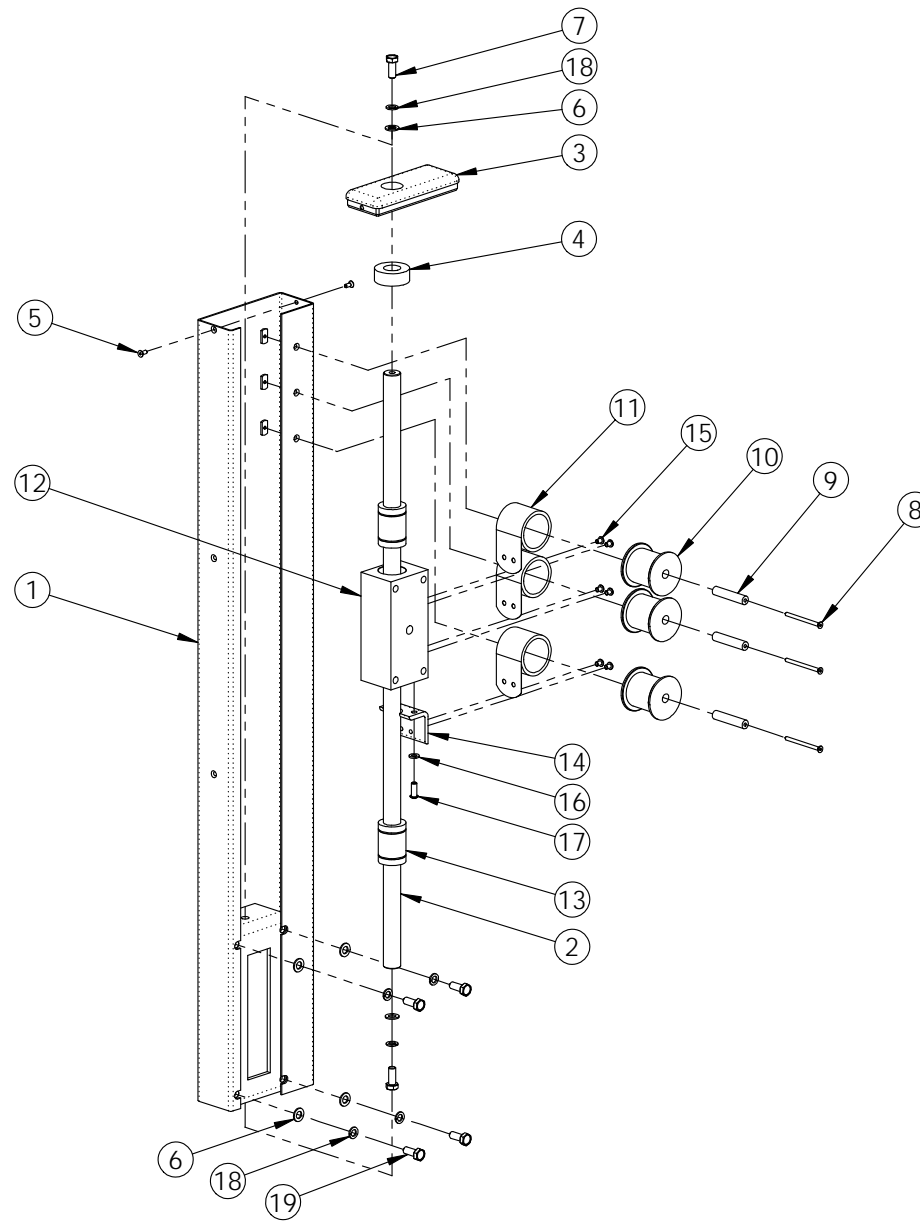

USM7075

ITEM	PART #	DESCRIPTION	QTY.
1	UPM7686	COLUMN TBD 24 LEFT SIDE	1
2	UPM7688	COLUMN SHAFT	1
3	UPM0741EV	COLUMN CAP LEFT SIDE	1
4	UPM2251	SAFETY BUMPER	1
5	UF5400	FHCS M5-0.8 x 12 mm	2
6	UF3680	FW M10	6
7	UF6382	HHCS M10-1.5 x 25 mm	2
8	UF1157	FHCS M5-0.8 x 70	3
9	UPM0743	SPRING MANDREL SHAFT	3
10	UPM0742	SPRING SPOOL	3
11	UPM0740	CONSTANT FORCE SPRING 33 lbs	3
12	UPM0737EV	COLUMN BLOCK LEFT SIDE	1
13	LM 25UU	LINEAR BEARING 25 mm	2
14	UPM3730EV	3RD SPRING ANCHOR LEFT SIDE	1
15	UF1206	BHCS M6-1 X 8mm	6
16	UF0867	LW M8	2
17	UF1318	BHCS M8-1.25 x 20 mm	2
18	UF6371	LW M10	6
19	UF3647	HHCS M10-1.25 x 25 mm	4

USM0820

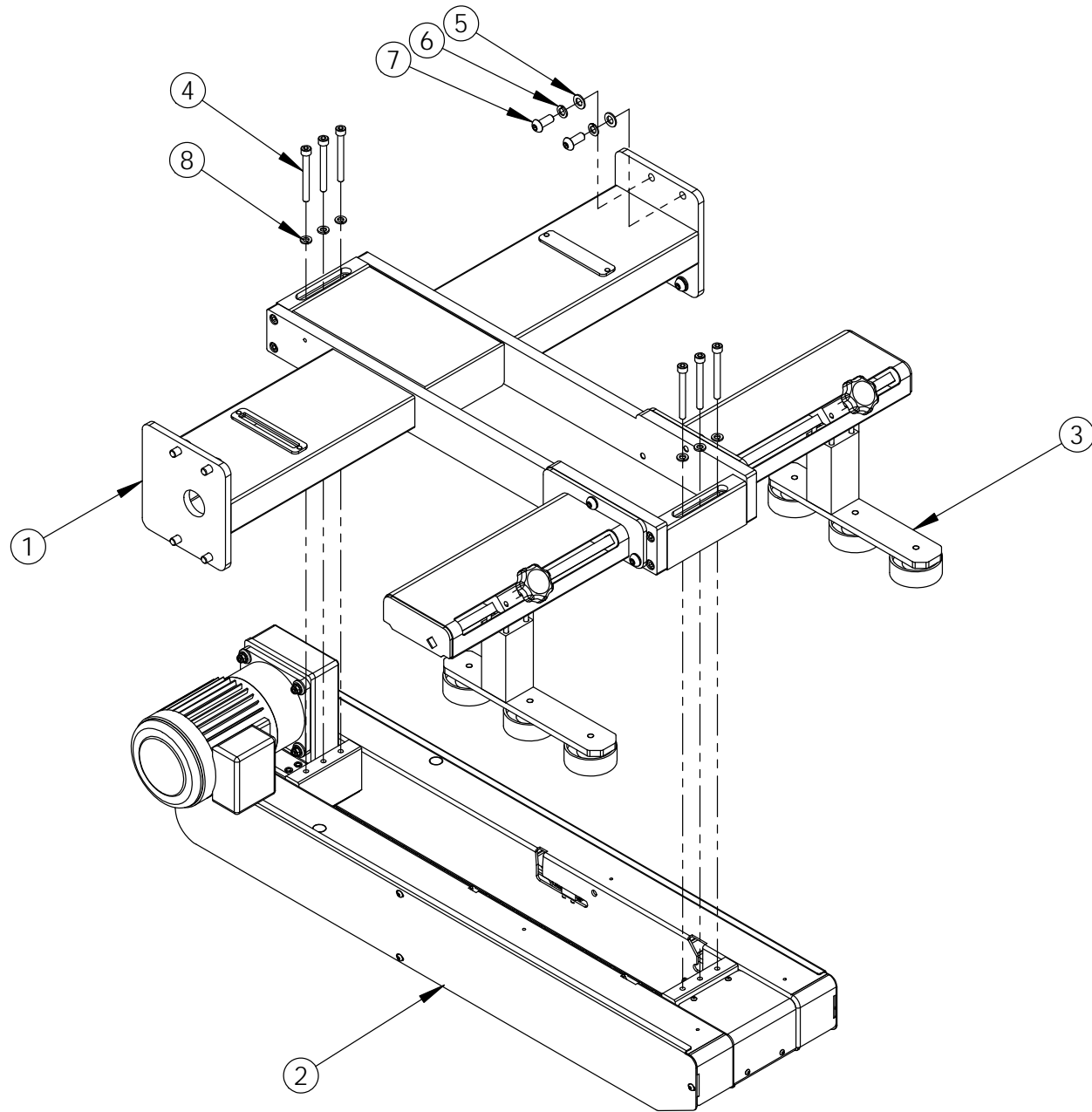

USM0820

ITEM NO.	PART NUMBER	DESCRIPTION	QTY.
1	UAM0283	BRIDGE USA2324 TB	1
2	USM0821	TBD SUB ASSEMBLY USA2324 3"	1
3	UAM0282	COMPRESSION GUIDE USA2324 TBD	2
4	UF6406	SHCS M8-1 X 75mm	6
5	UF3680	FW M10	8
6	UF6371	LW M10	8
7	UF6404	BHCS M10 - 1.5 x 25mm	8
8	UF0867	LW M8	6

UAM0283

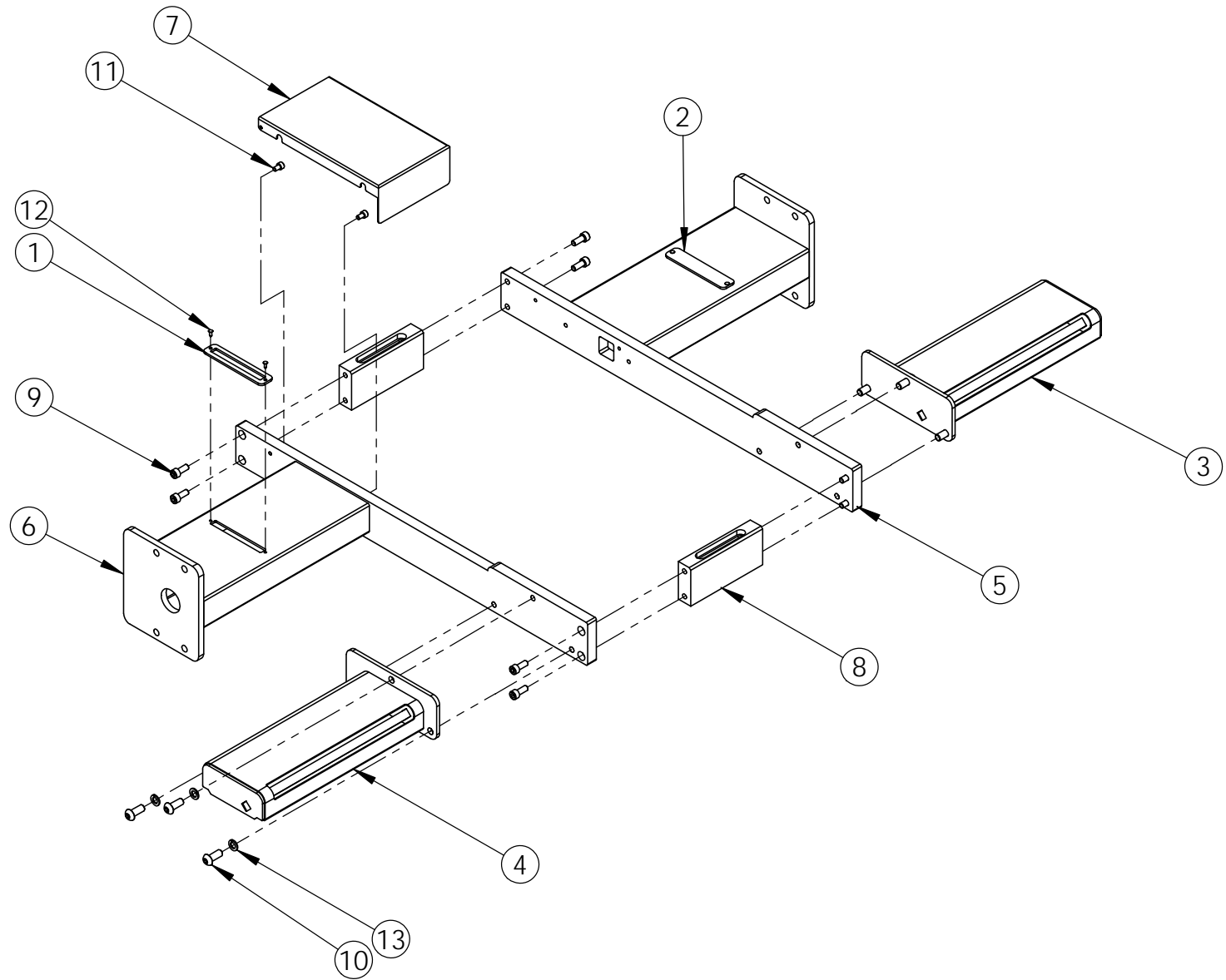

UAM0283

ITEM	PART #	DESCRIPTION	QTY.
1	UPM1011	BRIDGE PLATE COVER SLOTTED	1
2	UPM1008	BRIDGE PLATE COVER	1
3	UPM7490	TOP COMPR. GUIDE SUPPORT RIGHT SIDE	1
4	UPM7489	TOP COMPR. GUIDE SUPPORT LEFT SIDE	1
5	UPM7668	WING RIGHT SIDE	1
6	UPM7669	WING LEFT SIDE	1
7	UPM7676	BRIDGE COVER PLATE	1
8	UPM0961EV	CROSS BEAM SUPPORT TBD	2
9	UF5204	SHCS M8-1.25 x 20	8
10	UF6404	BHCS M10 - 1.5 x 25mm	6
11	UF6405	SHCS M6-1 x 10 mm	4
12	UPM2192	BLACK PLUG	4
13	UF6371	LW M10	6

USM0821

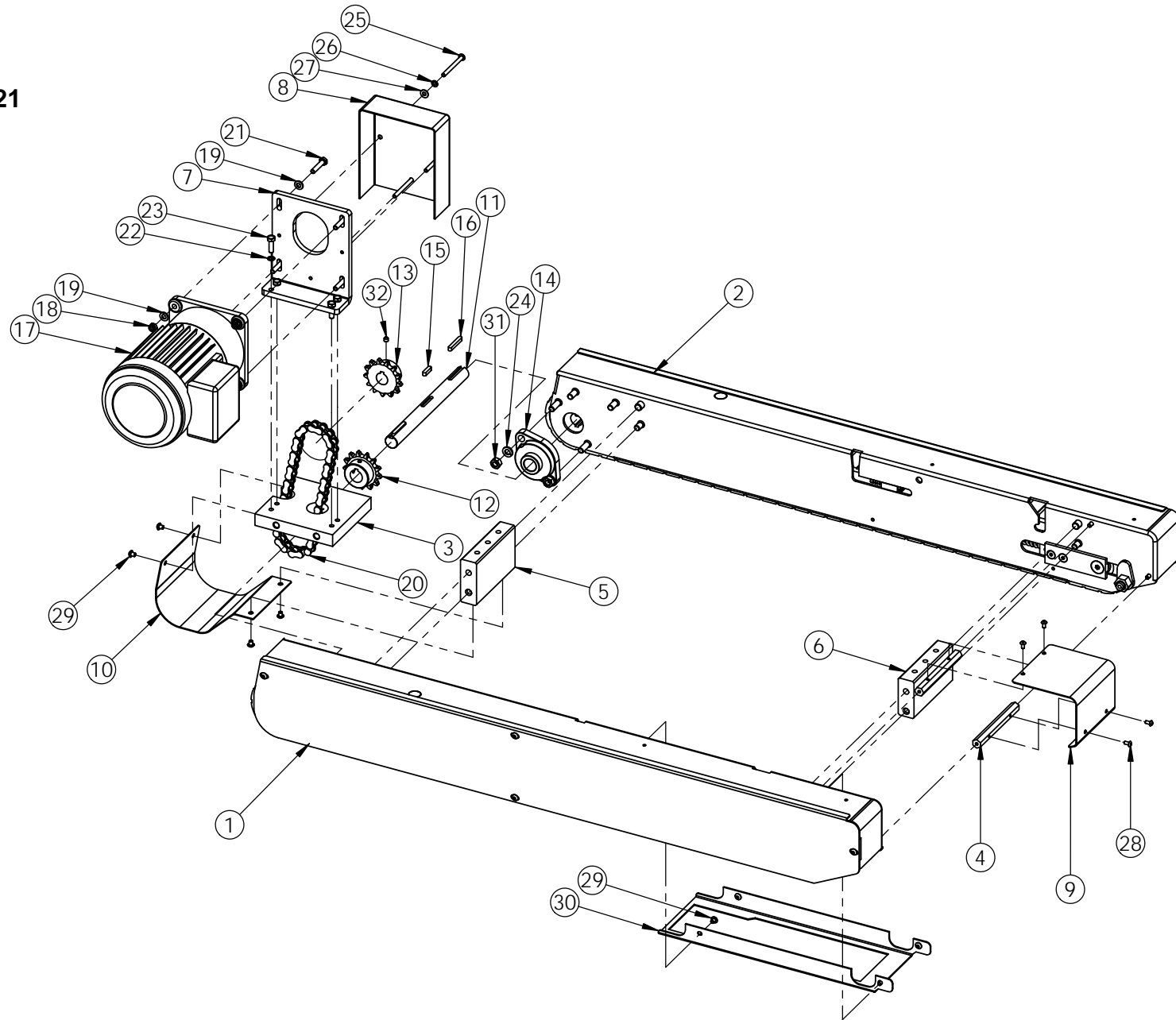

USM0821

ITEM NO.	PART NUMBER	DESCRIPTION	QTY.
1	UAM0413	TBD LH USA2324 3"	1
2	UAM0412	TBD RH USA2324 3"	1
3	UPM7675	Motor Support TBD 3"	1
4	UPM7670	HEX. BRACING 3"	2
5	UPM7672	Rear TBD Section Support 3"	1
6	UPM7673	Front TBD Section Support 3"	1
7	UPM7677	MOTOR BRACKET TBD METRIC	1
8	UPM1214EV	TOP CHAIN GUARD TBD	1
9	UPM4501	Inlet Cover TBD 3"	1
10	UPM7679	Chain hood, TBD 3" metric	1
11	UPM2120EV	Drive Pulley Shaft TW 3"	1
12	UPM0067EV	Sprocket RS141319 c/w 5mm Key way	1
13	UPM4118	Sprocket RS141318 c/w 5mm Key way	1
14	UPM0339	FLANGE BEARING 3/4" ID	2
15	UF2210EV	SQUARE KEY ROUND ENDS 5 X 5 X 20	1
16	UF6386EV	SQUARE KEY ROUND ENDS 5 X 5 X 35	2
17	UPM4504	Motor, Everroll 1/4 HP 20:1 Ratio	1
18	UF5900	NYLON LOCK NUT M6-1.0	4
19	UF1828	FW M6	8
20	UPM4421	CHAIN 40 - 37 PITCH + C.L. + O.L	1
21	UF3689	M6-1.0 X 30mm HHCS	4
22	UF6363	LW M6	4
23	UF3688	M6-1.0 X 20mm HHCS	4
24	UF0867	LW M8	4
25	UF3690	BHCS M5-0.8 x 55	3
26	UF7023	LW M5	3
27	UF1827	FW M5	3
28	UF3685	BHCS M4-0.7 x 8	4
29	UF5601	BHCS M5 X 0.8 X 6mm	8
30	UPM7499	GAP FILLER, TOP TH BOX	1
31	UF0866	HNR M8 - 1.25	4
32	UF1411	SSS M6 X 6mm	4

UAM0413

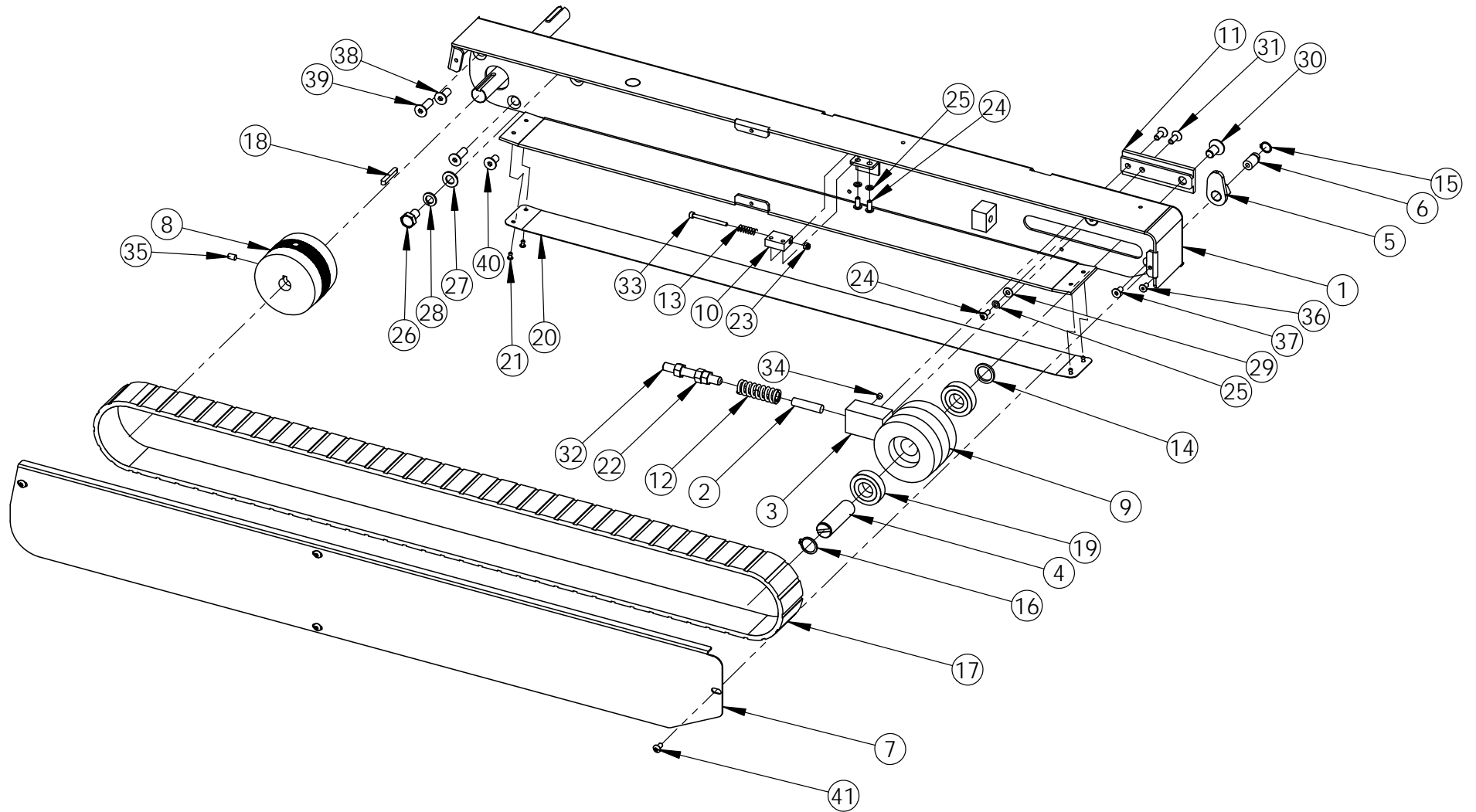

UAM0413

ITEM NO.	PART NUMBER	DESCRIPTION	QTY.
1	UPM6077	TB DRIVE SECTION LEFT SIDE	1
2	UPM0112	SPRING LOCATOR PIN	1
3	UPM0101EV	TENSIONNER SPRING HOLDER	1
4	UPM1233EV	IDLER PULLEY SHAFT 50mm	1
5	UPM4077	SPRING COMP TOOL L.H.	1
6	UPM4078	SHAFT	1
7	UPM4503	Side Cover TBD Left Side	1
8	UPM4450	DRIVE PULLEY	1
9	UPM0259	IDLER PULLEY	1
10	UPM7685	SPRING HOLDER BLOCK	1
11	UPM1879EV	TENSIONNER SLIDE	1
12	UPM0038	DIE SPRING - LHL-750B-5	1
13	UPM1068	COMP.SPRING SWIVEL T.H. ASSY	1
14	UPM0109	IDLER PULLEY SPACER	1
15	UF6300	RETAINING RING FOR 12mm SHAFT	1
16	UF2220EV	EXT RET'G RING 19mm	1
17	UPM7657	BELT DRIVE. SAG 12E, 50mm X 1915 LG	1
18	UF6386EV	SQUARE KEY ROUND ENDS 5 X 5 X 35	1
19	UPM0324EV	BEARING PULLEY USA2324	2
20	UPM0029	STRIP, UHMW, 2" W X .03" THK	1
21	UF2080	POP RIVET S-44	4
22	UF1540	HNR 3/8-16	3
23	UF6376	NYLON LOCKNUT M4	1
24	UF3687	BHCS M5-0.8 X 12mm	3
25	UF7023	LW M5	3

UAM0413

ITEM NO.	PART NUMBER	DESCRIPTION	QTY.
26	UF6308	HHCS M10-1.5 x 16mm	2
27	UF3680	FW M10	2
28	UF6371	LW M10	2
29	UF1827	FW M5	1
30	UF6397	FHCS M10-1.5 x 20	1
31	UF1192	FHCS M6-1 x 16 mm	2
32	UF1400	SSS HK 3/8-16 X 3	1
33	UF3644	SHCS M4-0.7 x 45	1
34	UF1411	SSS M6 X 6mm	1
35	UF3683	SSS M6 X 10mm	2
36	UF6305	FHCS M5-0.8 x 10 mm	1
37	UF1042	FHCS M6-1 x 12 mm	1
38	UF1190	M8 - 1.25 x 20 FHCS	2
39	UF6370	M8 - 1.25 x 25 FHCS	2
40	UF3684	M8 - 1.25 x 16 FHCS	2
41	UF3686	BHCS M5-0.8 X 10mm	4

THIS PAGE INTENTIONALLY BLANK

UAM0412

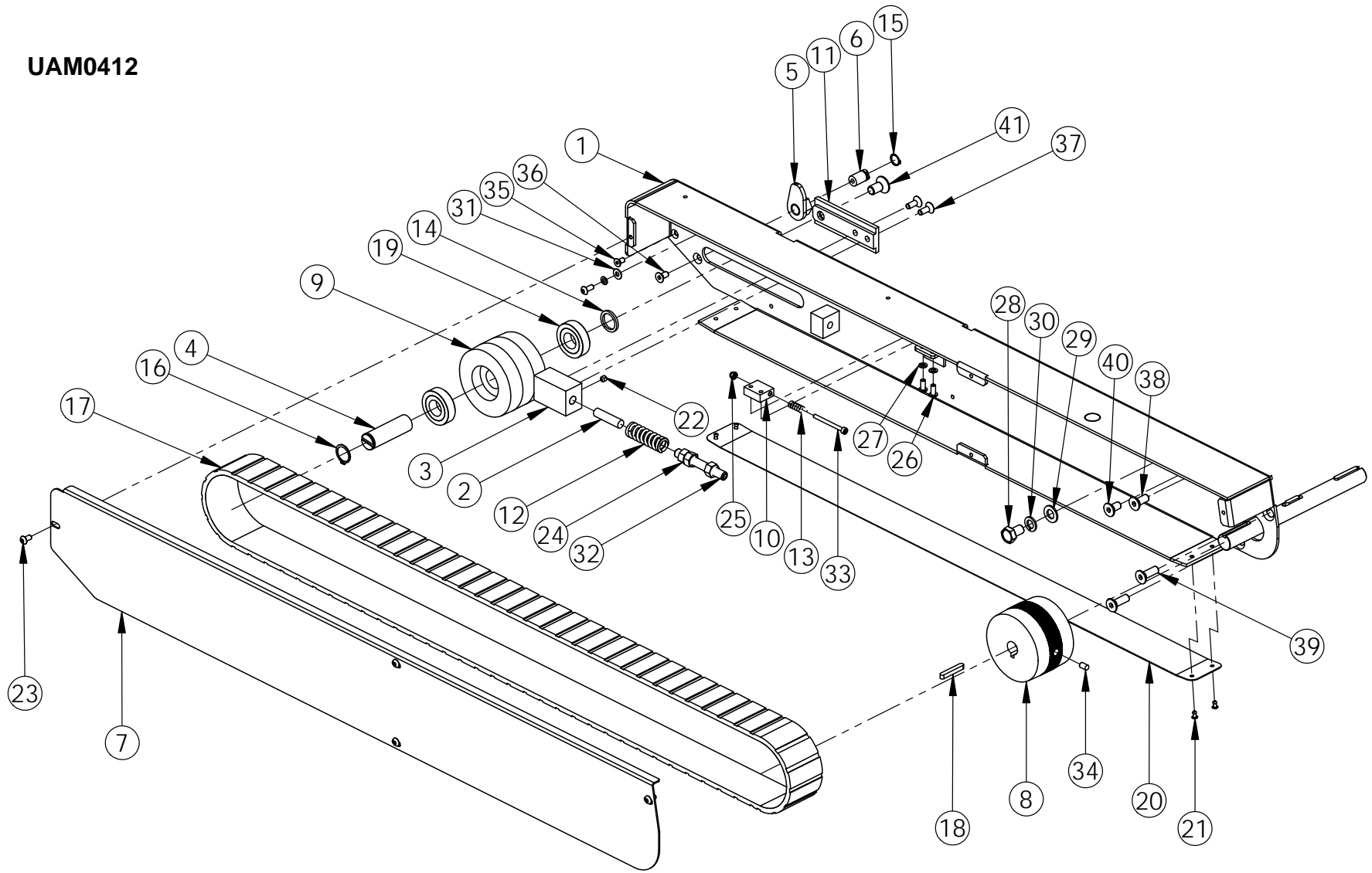

UAM0412

ITEM NO.	PART NUMBER	DESCRIPTION	QTY.
1	UPM6078	TB DRIVE SECTION RIGHT SIDE	1
2	UPM0112	SPRING LOCATOR PIN	1
3	UPM0101EV	TENSIONNER SPRING HOLDER	1
4	UPM1233EV	IDLER PULLEY SHAFT 50mm	1
5	UPM4076	SPRING COMP TOOL R.H.	1
6	UPM4078	SHAFT	1
7	UPM4502	Side Cover TBD Right Side	1
8	UPM4450	DRIVE PULLEY	1
9	SEE TABLE	IDLER PULLEY	1
10	UPM7685	SPRING HOLDER BLOCK	1
11	UPM1879EV	TENSIONNER SLIDE	1
12	UPM0038	DIE SPRING - LHL-750B-5	1
13	UPM1068	COMP.SPRING SWIVEL T.H. ASSY	1
14	UPM0109	IDLER PULLEY SPACER	1
15	UF6300	RETAINING RING FOR 12mm SHAFT	1
16	UF2220EV	EXT RET'G RING 19mm	1
17	UPM7657	BELT DRIVE. SAG 12E, 50mm X 1915 LG	1
18	UF6386EV	SQUARE KEY ROUND ENDS 5 X 5 X 35	1
19	UPM0324EV	BEARING PULLEY USA2324	2
20	UPM0029	STRIP, UHMW, 2" W X .03" THK	1
21	UF2080	POP RIVET S-44	4
22	UF1411	SSS M6 X 6mm	1
23	UF3686	BHCS M5-0.8 X 10mm	4
24	UF1540	HNR 3/8-16	3
25	UF6376	NYLON LOCKNUT M4	1

UAM0412

ITEM NO.	PART NUMBER	DESCRIPTION	QTY.
26	UF3687	BHCS M5-0.8 X 12mm	3
27	UF7023	LW M5	3
28	UF6308	HHCS M10-1.5 x 16mm	2
29	UF3680	FW M10	2
30	UF6371	LW M10	2
31	UF1827	FW M5	1
32	UF1400	SSS HK 3/8-16 X 3	1
33	UF3644	SHCS M4-0.7 x 45	1
34	UF3683	SSS M6 X 10mm	2
35	UF6305	FHCS M5-0.8 x 10 mm	1
36	UF1042	FHCS M6-1 x 12 mm	1
37	UF1192	FHCS M6-1 x 16 mm	2
38	UF1190	M8 - 1.25 x 20 FHCS	2
39	UF6370	M8 - 1.25 x 25 FHCS	2
40	UF3684	M8 - 1.25 x 16 FHCS	2
41	UF6397	FHCS M10-1.5 x 20	1

THIS PAGE INTENTIONALLY BLANK

UAM0282

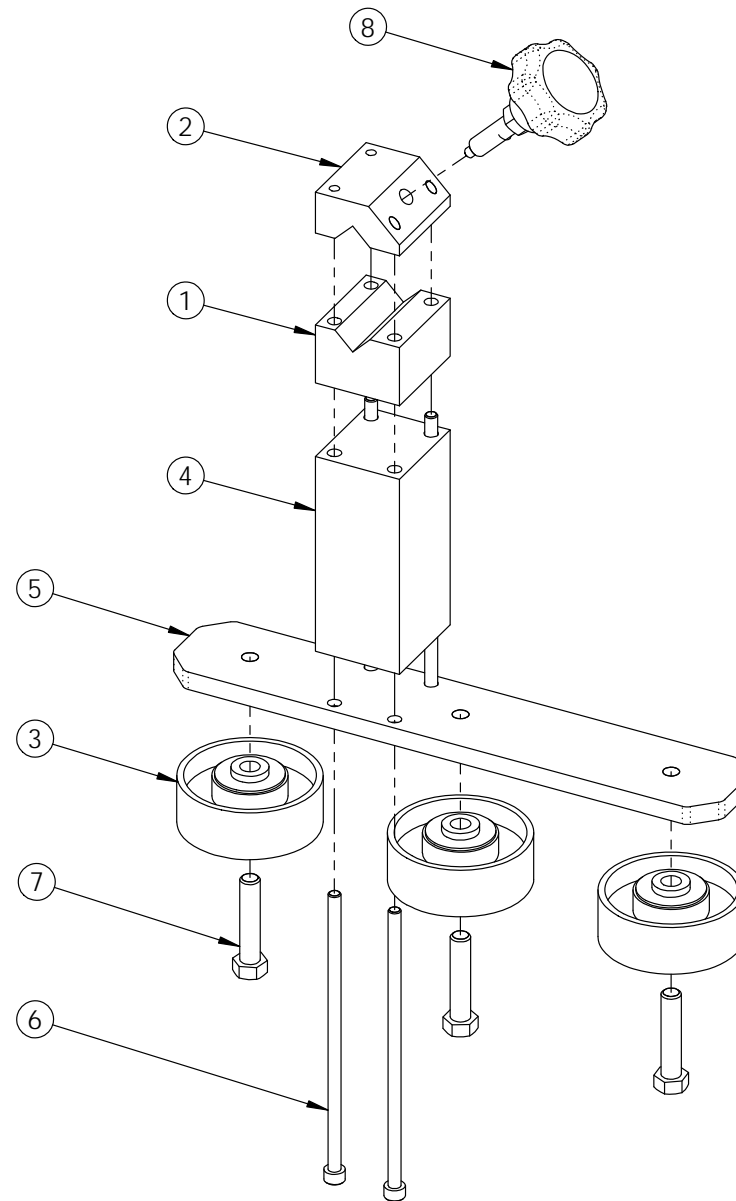

UAM0282

ITEM	PART #	DESCRIPTION	QTY.
1	UPM3285EV	GUIDE BLOCK	1
2	UPM7538	GUIDE BLOCK TOP	1
3	UPM1659	WHEEL 2-7/8"DIA.COMPR.GUIDE	3
4	UPM7680	WHEEL GUIDE SPACER	1
5	UPM7682	WHEEL SUPPORT PLATE TBD	1
6	UF9167	SHCS M6-1 X 150MM	4
7	UF0240	HHCS 3/8-16 x 1.75	3
8	UAM0288	KNOB CW 5mm PIN USA2324	1

USM0391

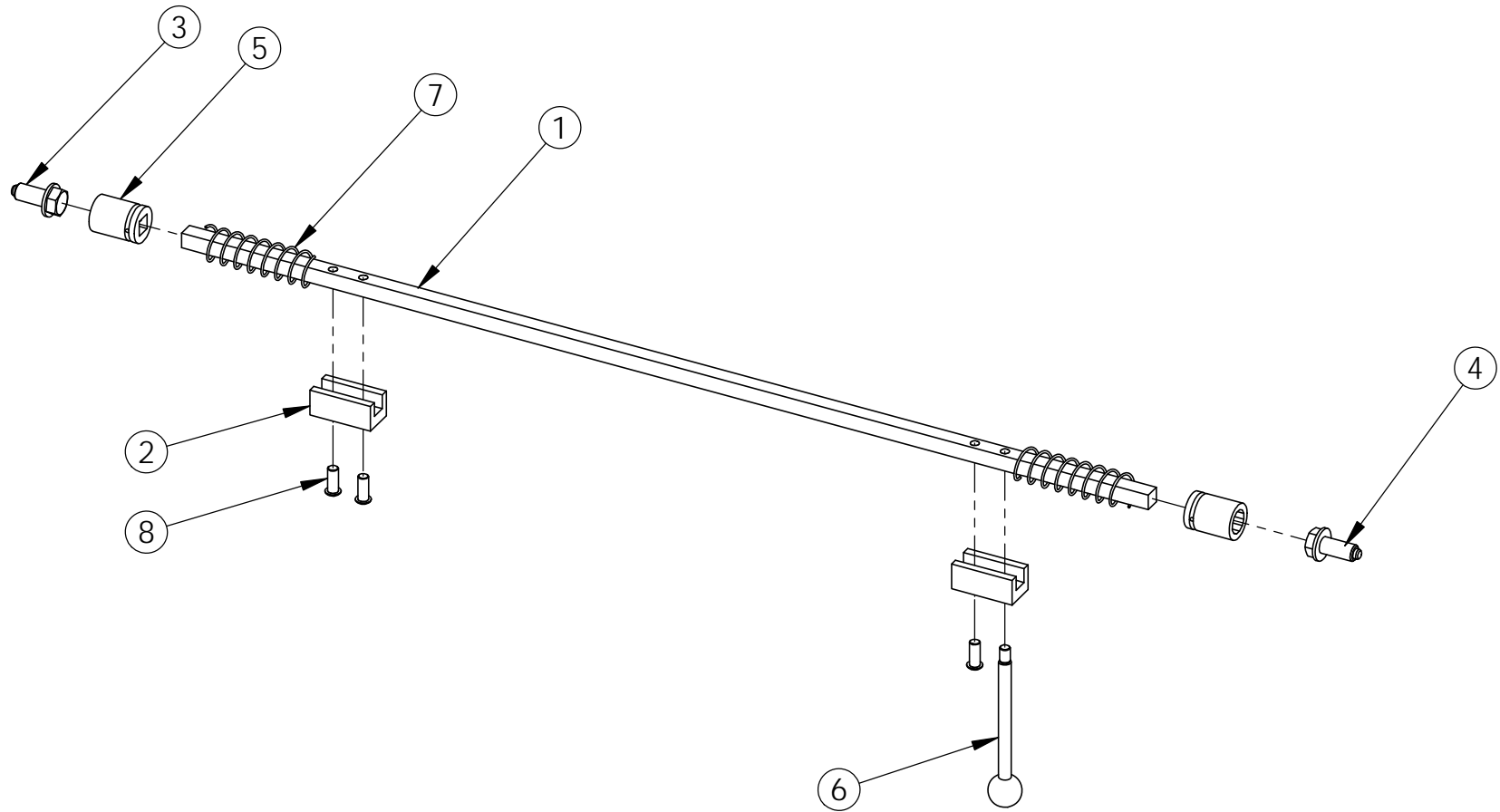

USM0391

ITEM	PART #	DESCRIPTION	QTY.
1	UPM2187	SQUARE BAR 0.50"	1
2	UPM0700	SINGLE LOCKING BLOCK	2
3	UPM0698	FLANGED SCREW 1/2-13 L.H.	1
4	UPM0699	FLANGED SCREW 1/2-13 R.H.	1
5	UPM0703	SHORT BOX 3/4", 1/2" DR, 12 PT	2
6	UPM0688EV	SINGLE LOCKING HANDLE	1
7	UPM2184	SPRING, C1100-065-4000-M	2
8	UF1318	BHCS M8-1.25 x 20mm	3

USM7561

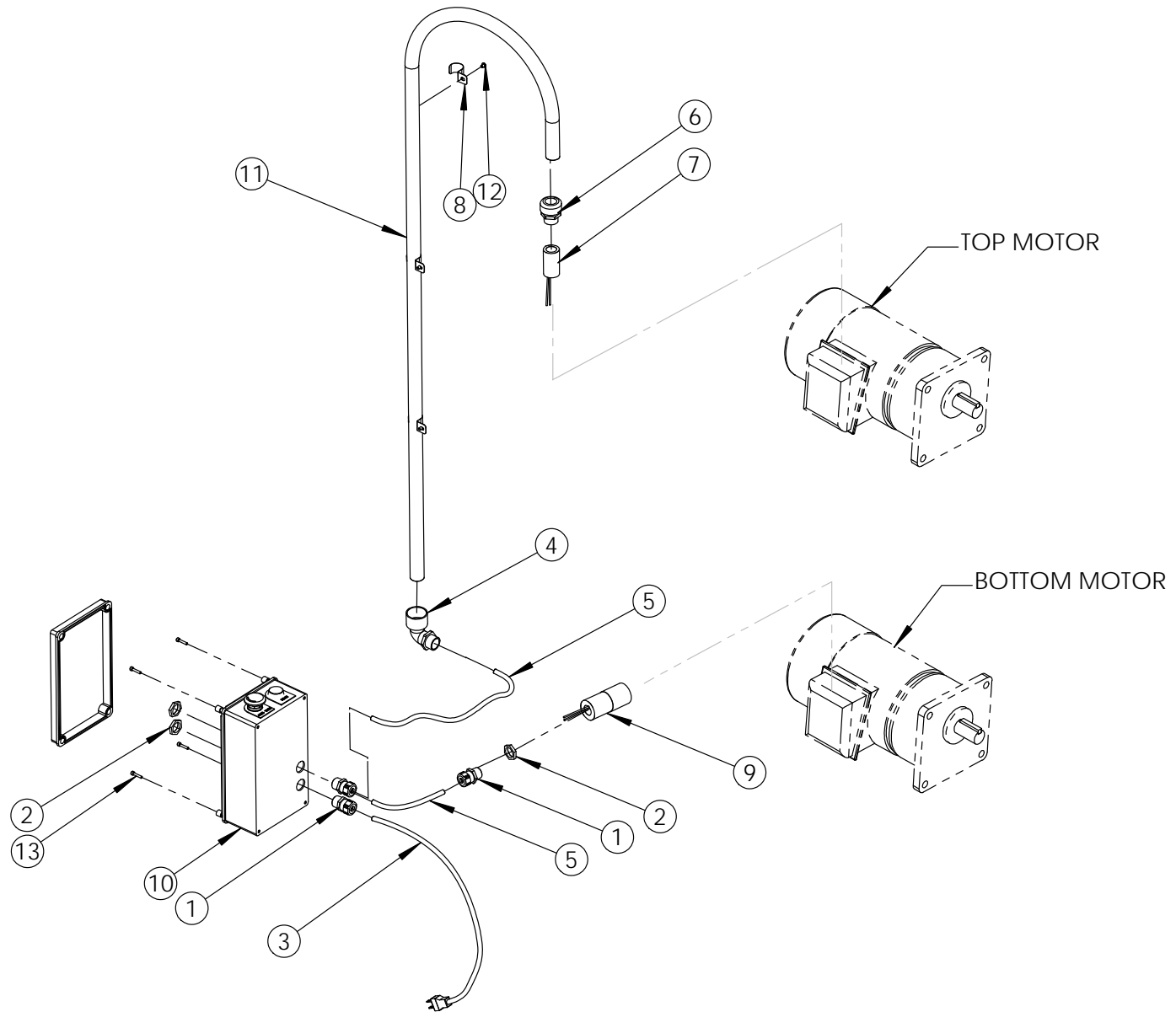

USM7561

ITEM NO.	PART NUMBER	DESCRIPTION	QTY.
1	UPM0197EV	STR.RELF METL.LIQDTGHT M20X1.5 (8-10mm)	3
2	UPM0341EV	LOCKNUT M20 X 1.5(FOR STRAIN RELF)	3
3	UPM0209	POWER CORD, 14/3	1
4	UPM1404EV	PLASTIC HUB CONNECTOR 25mm/90	1
5	UPM0225	CABLE 18/3 TYPE SJ	2
6	UPM4507	PLASTIC HUB CONN 25mm STRAIGHT	1
7	UPM9719	CAPACITOR 16uF	1
8	UPM1410EV	STRAP RING 25 mm	3
9	UPM4508	CAPACITOR 40 mF	1
10	UAM0289	ELECTRIC CONTROL BOX ASSEMBLY	1
11	UPM1982EV	FLEXIBLE TUBING 25mm	1
12	UF5601	BHCS M5 X 0.8 X 6mm	3
13	UF3646	SHCS M4-0.7 x 20	4

UAM0289

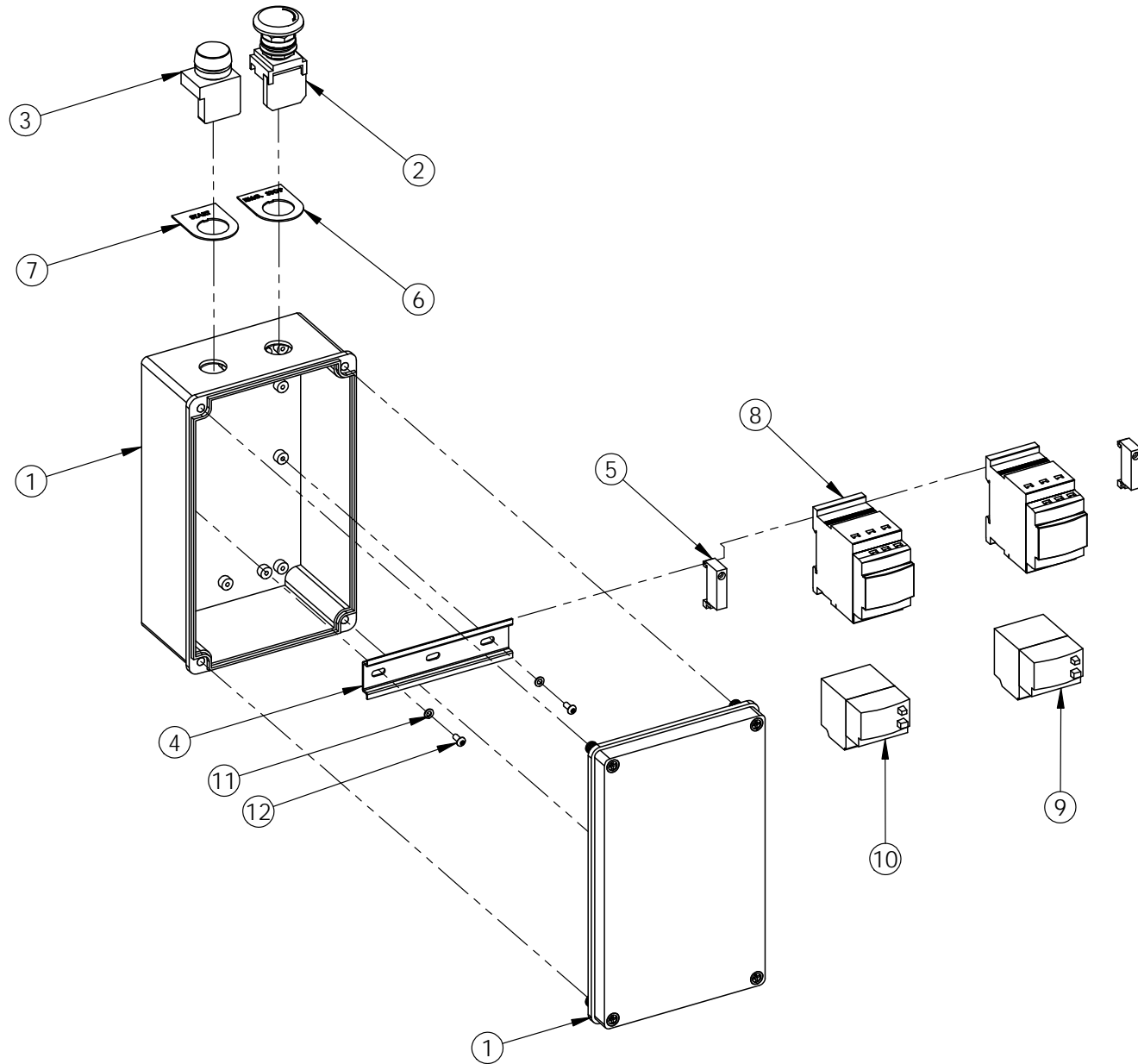

UAM0289

ITEM NO.	PART NUMBER	Description	QTY.
1	UPM7527	ENCLOSURE DEMEX HIBOX 132 X 232	1
2	UPM2211	BUTTON MUSHROOM 22mm 1 N.C.	1
3	UPM2212	BUTTON GREEN 22mm 1 N.O.	1
4	UPM0407EV	DIN RAIL USA 2324	1
5	UPM7440EV	TB END ANCHOR FOR DN SER	2
6	UPM2209EV	LEGEND PLATE "E-STOP"	1
7	UPM2210EV	LEGEND PLATE "START"	1
8	UPM7524	MOTOR STARTER TELEMEC 110VAC	2
9	UPM4505	MOTOR O/L TELEMEC 7-10A	1
10	UPM2213EV	MOTOR O/L TELEMEC 2.5-4.0A	1
11	UF3710	FW M4	2
12	UF6365	BHCS M4 x 0.7 x 10mm	2

UM9003

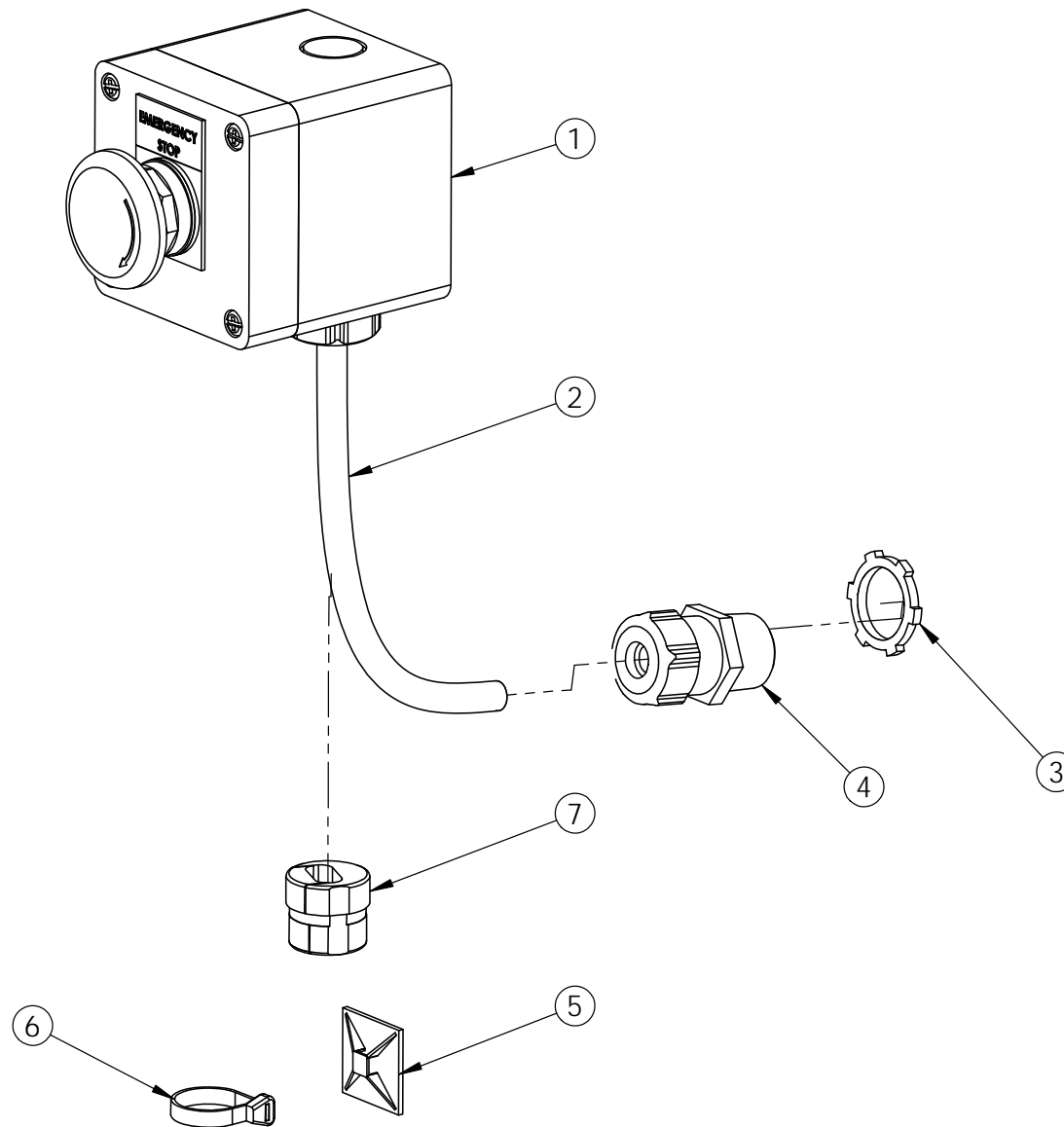

UM9003

ITEM	PART #	DESCRIPTION	QTY.
1	USM8075	SECOND E-STOP BOX FOR USA	1
2	UPM0225	CABLE 18/3 TYPE SJ	1
3	UPM0341	LOCKNUT 1/2"(FOR STRAIN RELF)	1
4	UPM0197	STR.RELF METL.LIQDTGHT 1/4-3/8	1
5	UPM0200	MTG. CLAMP,ADH.1.2"X1.2"	1
6	UPM0222	TY-RAP,5.5"X.14"	1
7	UPM0285	STRAIN RELIEF, NON-METAL	1

USM8075

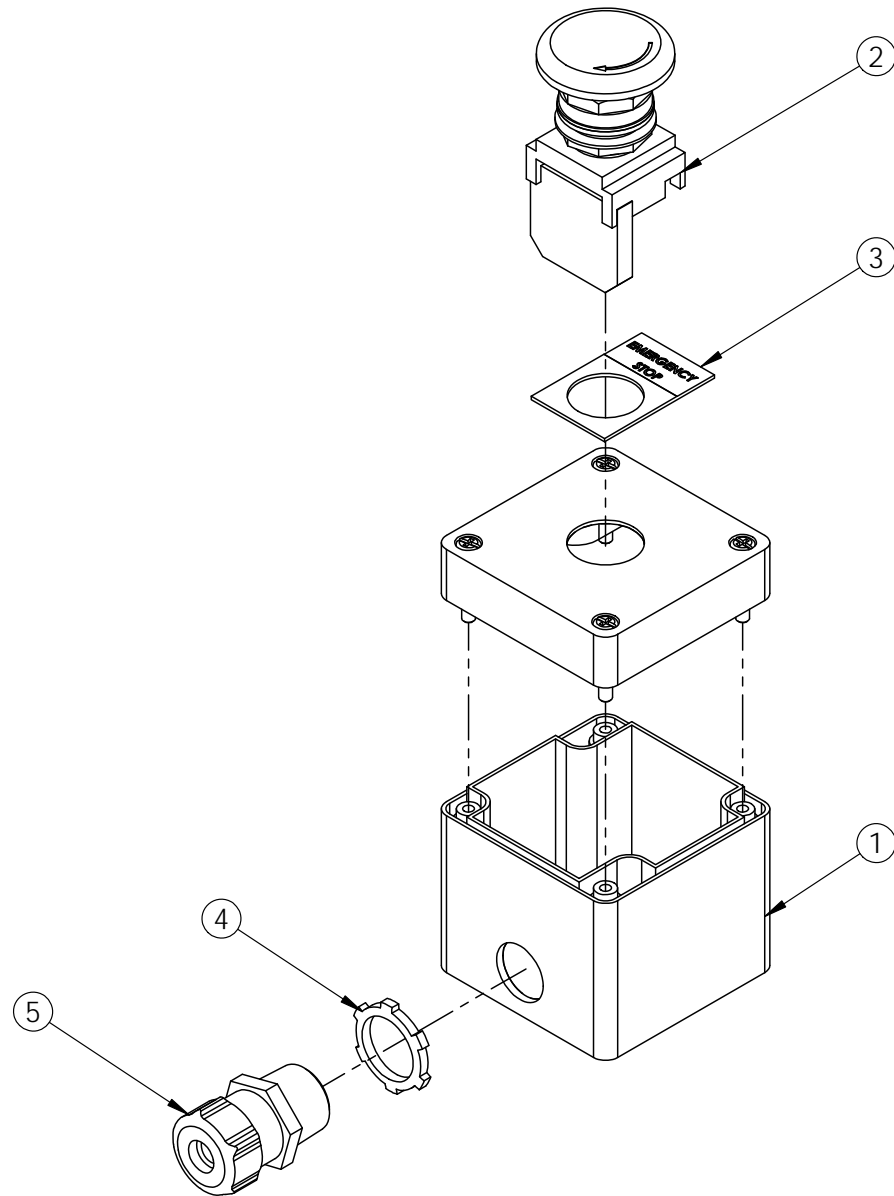

USM8075

ITEM	PART #	DESCRIPTION	QTY.
1	UPM7293	ENCLOS PB 1 HOLE NON METAL	1
2	UPM2211	BUTTON MUSHROOM 22mm 1 N.C.	1
3	UPM2209	LEGEND PLATE "E-STOP"	1
4	UPM0341	LOCKNUT 1/2"(FOR STRAIN RELF)	1
5	UPM0197	STR.RELF METL.LIQDTGHT 1/4-3/8	1

Electrical Drawing

