



USER MANUAL

USA 3036-SB



For Serial Numbers:
TM509 XX X XXX



TABLE OF CONTENTS

TABLE OF CONTENTS	2
SERVICE INSTRUCTIONS	4
WARRANTY	5
DESCRIPTION OF USA 3036-SB.....	6
SAFETY ISSUES	7
SAFETY ISSUES	8
SPECIFICATIONS	10
SPECIFICATIONS	11
SPECIFICATIONS	12
SET-UP PROCEDURES	13
SET-UP PROCEDURES	14
SET-UP PROCEDURES	15
SET-UP PROCEDURES	16
SET-UP PROCEDURES	17
OPERATING INSTRUCTIONS.....	18
MAINTENANCE	19
TROUBLESHOOTING	20
RECOMMENDED SPARE PARTS LIST	21
APPENDIX A – ILLUSTRATIONS AND PARTS LISTS	22

REVISION CONTROL

REV02 UPDATED
REV03 UPDATED SPARE PARTS
REV04 UPDATED

SERVICE INSTRUCTIONS

Service

This is the Interpack Model USA 3036-SB Uniform Side Belt Case Sealer you ordered. It has been set up and tested in our factory with Intertape manufactured pressure sensitive tapes. If any problems occur when setting up or operating this equipment, please contact the authorized distributor from where you purchased this item.

Should you need to contact **Interpack Technical Support**, please have the Case Sealer **model number and serial number** available. This information can be found on the nameplate of the side panel of the machine. Interpack Technical Support is available during normal business hours (Eastern Time).

PHONE 813-621-8410 x101

If you have a technical question that does not require an immediate response, you may contact Interpack by fax.

FAX 813-621-8449

Replacement Parts

Order parts by item number, part name and quantity required. Replacement parts are available from your Authorized Interpack Distributor exclusively.

Should you require assistance selecting the correct part, you may call:

Intertape Polymer Group
Interpack Machinery
9940 Currie Davis Drive, Suite 23B
Tampa, FL, 33619

Tel: 1-800-474-8273 Option 3
Fax: 1-800-462-1293

MODEL: _____

SERIAL NUMBER: _____

DISTRIBUTOR PURCHASED FROM: _____

DATE OF PURCHASE: _____

WARRANTY

EQUIPMENT WARRANTY AND LIMITED REMEDY: The following warranty is made in lieu of all other warranties, express or implied, including, but not limited to, the implied warranty of merchantability, the implied warranty of fitness for a particular purpose, and any implied warranty arising out of a course of dealing, a custom or usage of trade:

Intertape sells its Interpack Tape Heads, Case Tapers and Case Erectors with the following warranties:

1. The HSD® 2000 Tape Heads' knife blades, springs and wipe down rollers will be free from all defects for a period of ninety (90) days.
2. All other HSD® 2000 Tape Head parts will be free from all defects for one (1) year after delivery.
3. Water Activated Tapers' blades and brushes will be free from defects for ninety (90) days after delivery
4. Drive Belts will be free from defects for ninety (90) days after delivery
5. The Gear Motors will be free from defects for one (1) year after delivery.
6. All other components for Case Tapers and Case Erectors will be free from defects for one (1) year after delivery.

If any part is proven defective within its warranty period, then the exclusive remedy and Intertape's and the seller's sole obligation shall be, at Intertape's option, to repair or replace the part, provided the defective part is returned immediately to Intertape's factory or an authorized service station designated by Intertape.

A part will be presumed to have become defective after its warranty period unless the part is received or Intertape is notified of the problem no later than five (5) calendar days after the warranty period.

If Intertape is unable to repair or replace the part within a reasonable time, then Intertape, at its option, will replace the equipment or refund the purchase price. Intertape shall have no obligation to install the repaired or replacement part.

Intertape shall have no obligation to provide or pay for the labor required to install the repaired or replacement part. Intertape shall have no obligation to repair or replace (1) those parts failing due to: operator misuse, carelessness, or due to any accidental cause other than equipment failure, or (2) parts

1. Failure or damage is due to misapplication, lack of proper maintenance, abuse, improper installation or abnormal conditions such as temperature, moisture, dirt or corrosive matter, etc.
2. Failure due to inadequate cleaning, improper operating environment, improper utilities or operator error.
3. Failure due to operations above the rated capacities, or in any other improper manner, either intentional or otherwise.
4. Failure is due to equipment, which has been altered by anyone other than an authorized representative of Intertape Polymer Group.
5. Failure is due to an attempt by the purchaser to correct alleged defective equipment. In this event the purchaser is responsible for all expenses incurred.

LIMITATION OF LIABILITY: Intertape and seller shall not be liable for direct, indirect, special, incidental or consequential damages based upon breach of warranty, breach of contract, negligence, strict liability or any other legal theory.

The foregoing Equipment Warranty and Limited Remedy and Limitation of Liability may be changed only by written agreement signed by authorized officers of Intertape and seller.

DESCRIPTION OF USA 3036 - SB

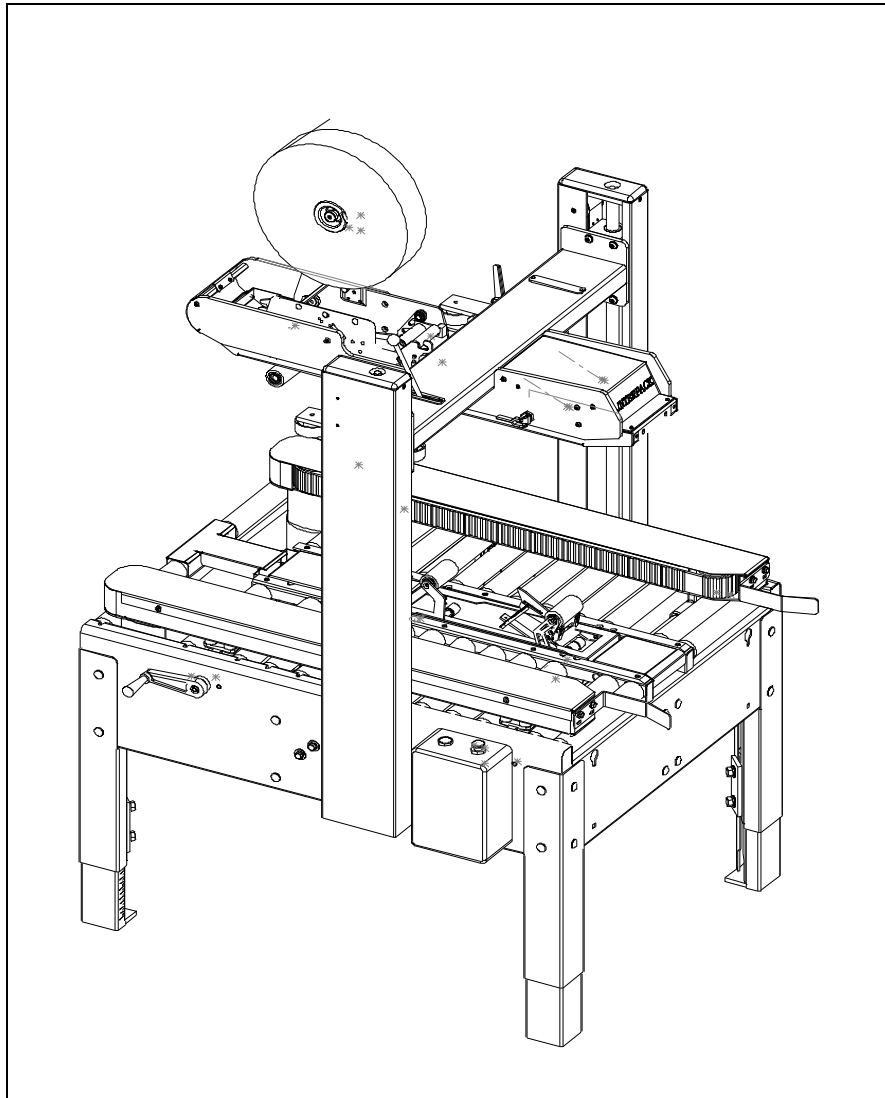

Figure 1

The Interpack USA 3036-SB Carton Sealing Machine with HSD[®] 2000 ETII Tape Heads is designed to apply Intertape brand pressure sensitive carton sealing tape to the top and bottom center seam of regular slotted corrugated cartons. The USA 3036-SB is manually adjustable to a wide range of carton sizes (see Carton Size Capacity, page 12) and permits processing of underfilled and overfilled applications by means of compression guides and a one-inch floating top tape head assembly. The self-centering Side Belt Drive system makes carton width adjustment effortless. The USA 3036-SB Carton Sealer features mirror image controls to facilitate its adaption into an existing conveyor line.

SAFETY ISSUES

There are a number of safety labels used on Interpack Carton Sealers. These labels are placed at different locations (refer to figure 2) on the machine to warn operators and service personnel of possible dangers. Please read the labels on the machine and the following safety precautions before using the machine.

- ✓ **Read this manual for other important safety operating and service information.**
- ✓ **Only trained personnel are to operate and service machine.**
- ✓ **Wear safety glasses.**
- ✓ **Shut off power to machine before adjusting.**
- ✓ **Unplug electrical power before servicing.**
- ✓ **All covers and guards must be in place before operating.**
- ✓ **Stay clear of moving parts which can shear and cut.**
- ✓ **Never operate the Tape Heads with the Knife Guard removed.**
- ✓ **Turn electrical supply off before servicing the Tape Heads, including tape loading and threading.**

SAFETY ISSUES

PLACEMENT OF WARNING LABELS

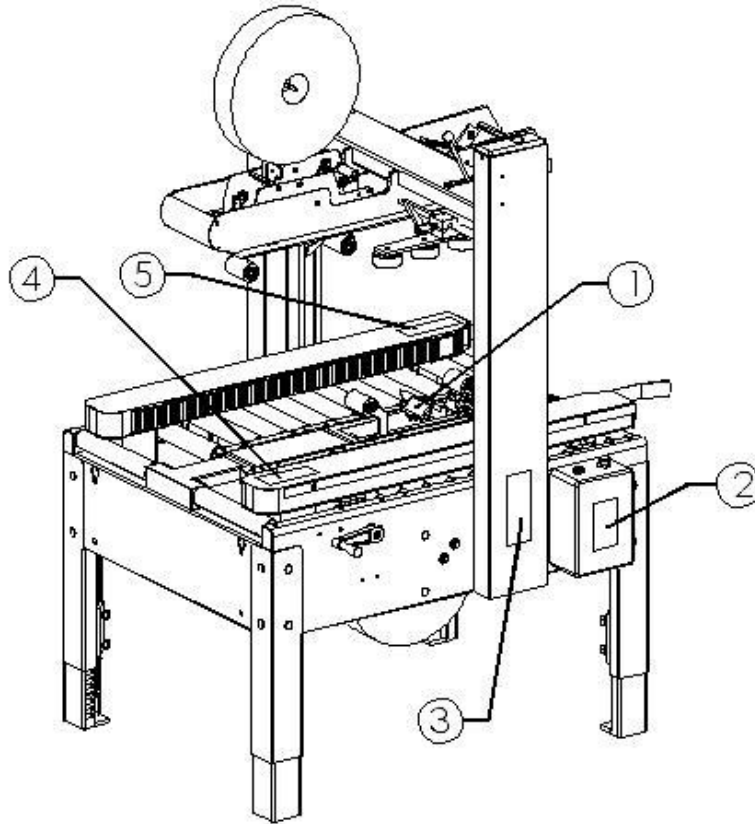

Figure 2

1)

⚠ WARNING

Sharp
Cutting
Blade

(The same label can be found on the top
tape head as well)

2)



3)

WARNING

OPERATION / SERVICE

- Only trained people are to operate and service machine.
- Shut off power to machine before adjusting.
- Unplug electrical power before servicing.

MACHINE MANUAL

For other important safety, operating and service information read this machine's manual.

EYE HAZARD

Wear Safety Glasses which conform to ANSI Std. Z87.1 or EN 166



COVERS AND GUARDS

All covers and guards must be in place before operating machine.

ELECTRICAL SHOCK

Hazardous voltages may cause personal injury. Only authorized and qualified personnel are to service electrical enclosures.



FAILURE TO FOLLOW THE ABOVE COULD RESULT IN SEVERE INJURY.

4)

WARNING



Moving machine parts can crush, cut and shear.

Disconnect and lockout all power before servicing machine.

Failure to follow the above can result in severe personal injury.

5)

WARNING



Moving parts can shear and cut. Disconnect and lockout all power before servicing machine. Failure to follow the above can result in severe personal injury.

Note: Should any of the safety labels shown in Figure 2 be damaged or destroyed, replacements are available.

SPECIFICATIONS

Machine Dimensions

Overall outside dimensions:

- Height: 90 inches maximum
- Length: 51 inches
- Width: 52 ½ inches

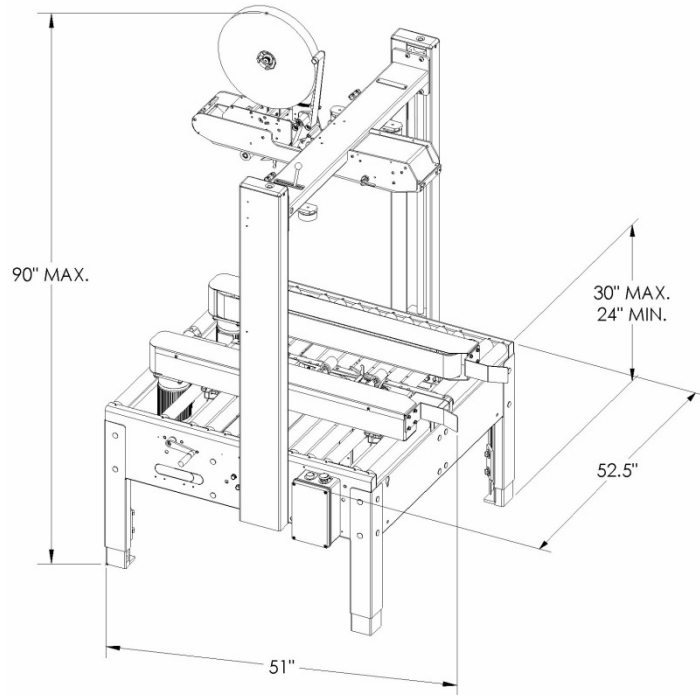

Figure 3

Machine Weight

The machine weighs 645 lbs.

Power Requirements

Electrical - 115 VAC, 60 HZ, 9.6 A.

Standard electrical equipment:

- Two (2) 1/3 H.P. gear motors,
- A neoprene power cord, and
- A grounded plug.

Contact your Intertape representative for power requirements not listed above.

Operating Speed

Belt speed is 82 feet per minute. Actual production rate is dependent on operator's dexterity and the case size mix.

SPECIFICATIONS

Operating Conditions

Use in a dry, relatively clean environment at 40° to 105° F (5° to 40° C) with clean dry cartons.

Tape

1) General

Use Intertape brand Pressure Sensitive Carton Sealing Tape.

2) Tape Width

2.5 to 3 inch wide tape (65 to 75 mm) maximum.

3) Tape Roll Diameter

Maximum of 16 inches (405 mm) on a 3-inch (76.2 mm) diameter core. (Accommodates all Intertape brand film tape machine roll lengths).

4) Tape Application Leg Length – Standard

2.5 inches (+0.25", -0") (63.5 mm, +6.3 mm, -0 mm).

5) Tape Application Leg Length – Optional

2 inches (+0.25", -0") (50.8 mm, +6.3 mm, -0 mm). Refer to HSD® 2000 ET II Tape Head manual for adjustment of tape application leg length.

Box Board

Style: regular slotted containers (RSC)
125 to 275 psi bursting test, single or double wall B or C flute.

Carton Weight Capacity

Up to 125 lbs.

SPECIFICATIONS

Carton Size Capacity

	Height (inches)	Width (inches)	Length (inches)
Standard <i>minimum</i>	5	4.5	6
<i>maximum</i>	36	30	Infinite

SET-UP PROCEDURES

Receiving and Handling

The machine is shipped to the customer in a box and fixed to a pallet.

- Remove the strapping and the staples at the bottom of the box.
- Lift off the box cover and sleeve.
- Remove the mounting bolts and nuts, which secure the USA 3036-SB to the shipping pallet.
- Lift the machine off the pallet and install it on your packaging line.
- Remove all tie wraps and other shipping materials.

Note: *After unpacking the machine, look for any damage that may have occurred during shipping. Should the machine be damaged, file a claim with the transport company and notify your Intertape representative.*

Setting-up

1) General

The Carton Sealer must be installed on a near level ground. Ensure that the machine is level and firmly on the ground (no rocking). Adjust the roller height with the four (4) telescopic adjustment legs to accommodate conveyor heights from 24 to 30 inches.

To adjust the Carton Sealer height, jack up the machine to give ample room to extend the legs. Using a 9/16" box end wrench, loosen the eight (8) 1/2" hex head bolts. Adjust the legs to the desired conveyor height and tighten the bolts. Etched scales on the legs facilitate proportionate leveling.

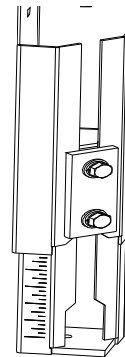

Figure 4

SET-UP PROCEDURES

Customer supplied infeed and exit conveyors (or rollers) must be level with the machine, otherwise, the performance of the machine may be affected. The customer-supplied infeed conveyor (if used) should provide straight and level entry. The customer-supplied exit conveyor (if used) should be straight and declined no more than 1/4 inch per foot away from the machine.

2) Electrical Connection

The electrical control can be located on either side of the Carton Sealer for customer convenience. It contains the green "on" push button and the red "E-Stop" mushroom push button, which is to be used both for emergency stops as well as regular halting of the machine.

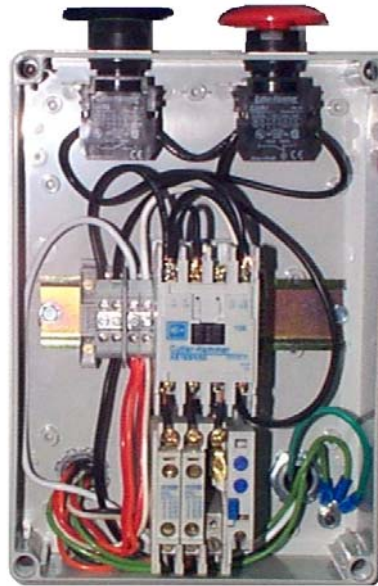

Figure 5

An eight (8) foot standard three conductor power cord with plug is provided for 115 V, 60 Hz, 15 amp electrical service. The servicing receptacle must be properly grounded. Before the machine is plugged into the receptacle, ensure that all materials are removed from the machine. The electrical control is protected with an automatic circuit breaker with resettable overload.

SET-UP PROCEDURES

3) Mirror Image Controls

Other than the electrical control box, there are three (3) other mirror image controls that can be placed on the right or the left hand side of the machine for easier operation.

1) Single Locking System

This system is located on the bridge of the Top Tape Head Box and is used to adjust the height of the Top Tape Head to the height of the carton. The lever is assembled on the left hand side. To change sides, simply remove the cap on the right, unscrew the lever and screw it back on the right side. Replace the cap on the left side.

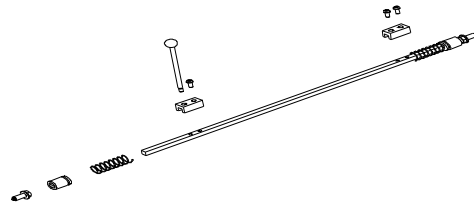

Figure 6

2) Locking Floating System

The lever for this system is located on the left side of the Top Tape Head Box. It has toggle clamp used to lock or unlock the floating system. For opposite side installation: remove red cover cap on right hand side, unscrew the toggle clamp with $\frac{3}{4}$ " wrench, replace one with the other, secure the toggle's position with the locknut.

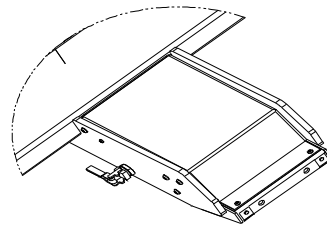

Figure 7

SET-UP PROCEDURES

3) Width Adjustment Handle

The foldable handle that is used to adjust the width of the self-centering side rails is located on the left hand side of the machine. Unscrew and change sides.

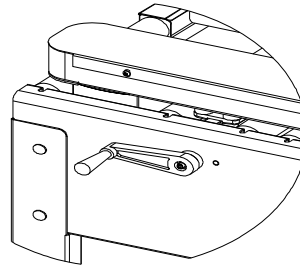

Figure 8

4) **Tape Loading and Threading**

A) Tape Loading

WARNING! *TURN OFF ELECTRICAL POWER SUPPLY AND DISCONNECT THE POWER CORD FROM THE ELECTRICAL SUPPLY BEFORE BEGINNING TO WORK ON THE TAPE HEADS OR TO LOAD TAPE. IF POWER CORDS ARE NOT DISCONNECTED, SEVERE INJURY TO PERSONNEL COULD RESULT.*

The HSD2000[®] ET II/2" tape heads accommodate 2-inch wide tape rolls, while the optional HSD2000[®] ET II/3" tape heads accommodate 3-inch wide rolls. See the label on the side of the HSD2000[®] ETII tape head for the loadable tape sizes.

Push the roll of tape onto the mandrel with the adhesive side up (refer to threading diagram on the HSD2000[®] ETII tape head) until the core is set against the mandrel flange. This ensures the tape will be aligned when feeding into the tape head.

SET-UP PROCEDURES

B) Tape Threading

WARNING! *THE KNIFE CONTAINED IN THE TAPE HEAD IS EXTREMELY SHARP. USE CAUTION WHEN REMOVING THE BLADE GUARD AND THREADING THE TAPE TO AVOID PERSONNEL INJURY.*

To thread the tape in the upper Tape Head, you do not require any special tools.

- Push the Tape Head towards the front of the machine and lift up.
- Pull approximately twelve (12) inches of tape from the roll and fold in half lengthwise. This allows you to thread the tape without it adhering to the guide and clutch rollers inside the Tape Head.
- Follow the tape-threading diagram on the side plate of the HSD® 2000 ETII Tape Head. Refer to your Tape Head manual for further information if required.
- Remove the blade guard from the knife in the Tape Head.
- Cut off the folded tape.
- Replace the upper Tape Head to its initial position.

To thread the lower Tape Head, no special tools are required.

- Lift the top Tape Head box to the uppermost position.
- Remove the lower Tape Head by grasping the tape application rollers and lifting straight up.
- Pull approximately twelve (12) inches from the roll and fold in half lengthwise. This allows you to thread the tape without it adhering to the guide and clutch rollers inside the Tape Head.
- Follow the tape-threading diagram on the side plate of the HSD® 2000 ET II Tape Head. Refer to your Tape Head manual for further information if required.
- Remove the blade guard from the knife in the Tape Head.
- Cut off the folded tape.
- Replace the lower Tape Head to its initial position.

OPERATING INSTRUCTIONS

Once the HSD® 2000 ETII Tape Heads (both bottom and top) have been loaded with tape and threaded, the machine is ready to process regular slotted cartons. The following instructions are presented in the order recommended for processing cartons successfully through the USA 3036-SB Carton Sealing machine.

1. Unlock the Single locking System and raise the Top Tape Head Box to its maximum.
2. Turn the Width Adjustment Handle to open the drive base in order to allow an empty test carton to slide on the machine
3. Place an empty test carton with the flaps held in closed position under the bridge of the Top Tape Head Box.
4. Adjust the self-centering side rails by turning the Width Adjustment Handle.
5. Block the Floating System by pushing the toggle clamp to "lock".
6. Lower the Top Tape head Box until it touches the top of the carton. Lock the Single Locking System.
7. Adjust the Compression Guides on the side of the carton.
8. Remove the test carton from the machine.
9. Ensure that the electrical power is on.
10. Switch the machine "on" with the start push button.
11. Process the first carton with the flaps in the closed position.
12. When the carton exits the Carton Sealer, process the next carton.

WARNING! **ENSURE THAT THE OPERATOR'S HANDS ARE AWAY FROM THE MOVING BELTS OF THE SIDE DRIVE BASE ASSEMBLY.**

Note: *Should any problem occur during processing that requires halting the machine, press the red "E-Stop" mushroom button.*

Note: *The machine should never be washed down or subjected to conditions causing condensation on components.*

MAINTENANCE

Depending on usage, grease acme shaft on a three months interval. Open up drive base by winding handle, apply grease to the acme shaft between the cast iron drive base supports, then close the drive base and repeat application to the outside of cast iron drive base supports. Recommended lubricants are: 1st Beacon 325 (ESSO brand), 2nd graphite base greases, and 3rd standard ball-bearing grease.

Spray column shaft once a month with silicon based dry film lubricant. This won't attract dust and lint from the surroundings.

No other lubrication is necessary to operate the machine.

TROUBLESHOOTING

Interpack Carton Sealers are fabricated with high quality components that provide trouble-free operation for a long period. However, should a problem occur, we recommend that you consult the following table. If the problem you encounter is not discussed in this table, call Intertape Customer Service Department (see page 2 of this document).

TROUBLE	POSSIBLE CAUSES	SOLUTIONS
Main power is turned "on" and nothing happens.	Overload protection by circuit breaker.	Check that all circuits are "on".
Cartons are not taped properly.	Tape Head is not adjusted correctly.	Refer to Tape Head manual.
Single Locking System is locked, still the Bridge of Top Tape Head Box is loose on one side	Brass pin is worn out and has lost contact with column shaft.	Lock Tape Head Box at its maximum height. On loose side, under the bridge, remove socket completely from screw head, unlock the Tape Head Box with the lever and re-insert socket. Refer to Figure 9

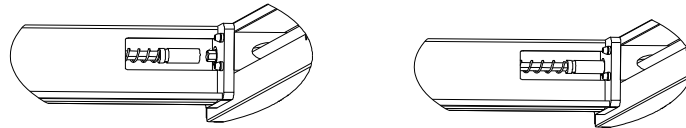

Figure 9

RECOMMENDED SPARE PARTS LIST

We recommend that you stock the following spare parts.

DESCRIPTION	ITEM NUMBER	RECOMMENDED QUANTITY
Bearing Pulley	UPM0324	2
Bumper	UPM0576	8
Belt	UPM2565	2
Linear Bearing	LM25UU	2
Constant Force Spring 33lbs.	UPM0740	2
Wheel 2-7/8" Dia. Compression Guide	UPM1659	3
Single Locking Handle	UPM0688EV	1

APPENDIX A – ILLUSTRATIONS AND PARTS LISTS

APPENDIX CONTENTS

UM509T (illustration).....	A-24
UM509T (parts list).....	A-25
BASE, STRUCTURE (illustration).....	A-26
BASE, STRUCTURE (parts list).....	A-27
LEG ASSEMBLY (illustration).....	A-28
LEG ASSEMBLY (parts list).....	A-29
ELECTRICAL ASSEMBLY (illustration).....	A-30
ELECTRICAL ASSEMBLY (parts list).....	A-31
ELECTRIC BOX (illustration).....	A-32
ELECTRIC BOX (parts list).....	A-33
COLUMN LEFT (illustration).....	A-34
COLUMN LEFT (parts list).....	A-35
COLUMN RIGHT (illustration).....	A-36
COLUMN RIGHT (parts list).....	A-37
BRIDGE WITH TAPEHEAD BOX (illustration).....	A-38
BRIDGE WITH TAPEHEAD BOX (parts list).....	A-39
BRIDGE SUB ASSEMBLY (illustration).....	A-40
BRIDGE SUB ASSEMBLY (parts list).....	A-41
TAPEHEAD BOX (illustration).....	A-42
TAPEHEAD BOX (parts list).....	A-43

PIVOT ASSEMBLY LEFT & RIGHT (illustration).....	A-44
PIVOT ASSEMBLY LEFT & RIGHT (parts list).....	A-45
SINGLE LOCKING DEVICE (illustration).....	A-46
SINGLE LOCKING DEVICE (parts list).....	A-47
COMPRESSION GUIDE (illustration).....	A-48
COMPRESSION GUIDE (parts list).....	A-49
CENTRING ASSEMBLY (illustration).....	A-50
CENTRING ASSEMBLY (parts list).....	A-51
DRIVE BASE ASSEMBLY RIGHT (illustration).....	A-52
DRIVE BASE ASSEMBLY RIGHT (parts list).....	A-53
DRIVE BASE ASSEMBLY LEFT (illustration).....	A-54
DRIVE BASE ASSEMBLY LEFT (parts list).....	A-55
SECOND E-STOP ASSEMBLY (illustration)	A-56
SECOND E-STOP ASSEMBLY (parts list).....	A-57
SECOND E-STOP BOX (illustration)	A-58
SECOND E-STOP BOX (parts list).....	A-59
ELECTRICAL DRAWING	A-60

UM509T

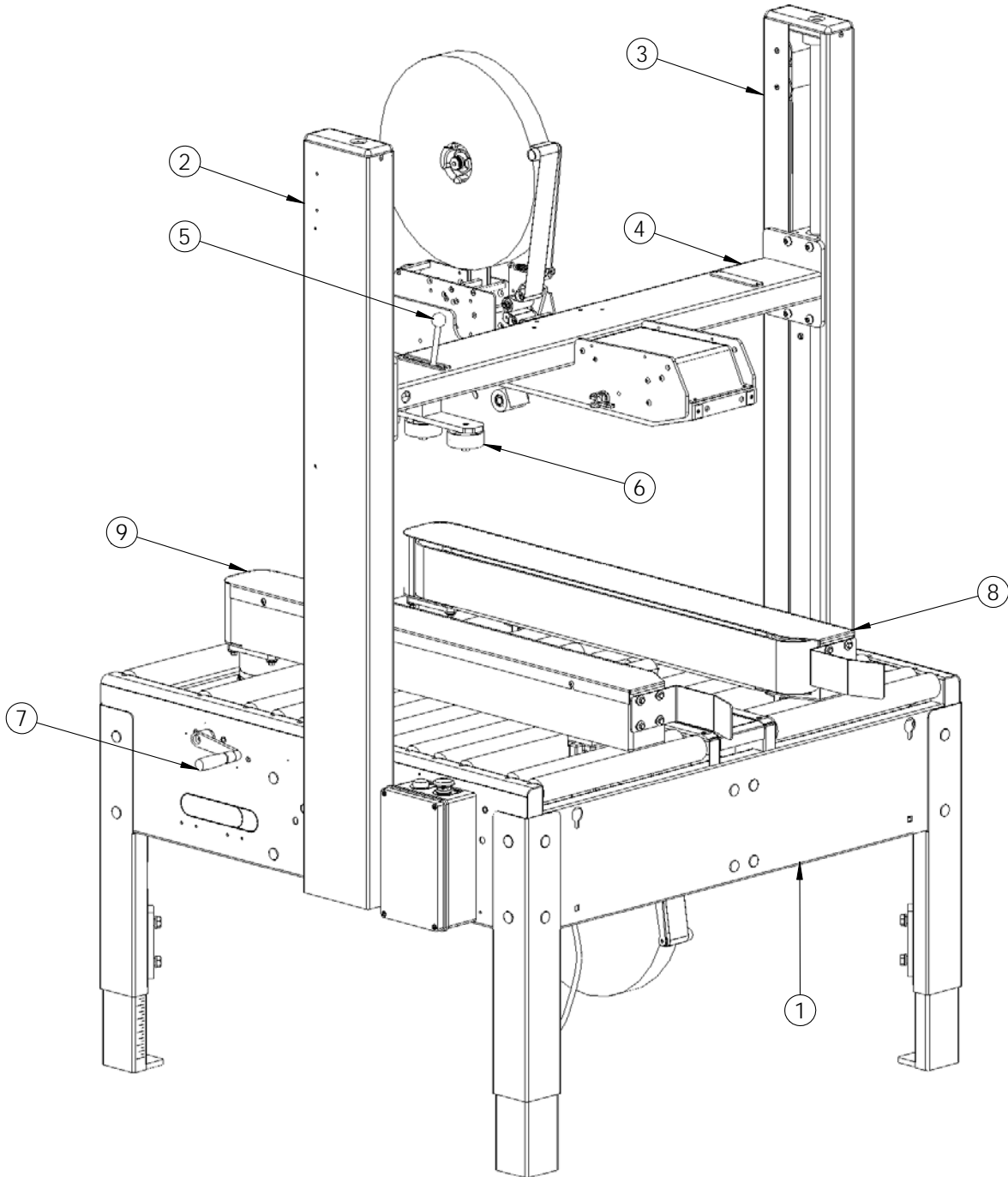

UM509T

ITEM	PART #	DESCRIPTION	QTY.
1	USM8110	BASE ASSEMBLY	1
2	USM8116	COLUMN 3036 SB LEFT	1
3	USM8117	COLUMN 3036 SB RIGHT	1
4	USM7564	BRIDGE WITH TAPEHEAD BOX	1
5	USM8114	SINGLE LOCKING DEVICE	1
6	UAM0260	COMPRESSION GUIDE USA2324 BB	2
7	USM8113	DRIVE CENTRING ASS'Y	1
8	UAM1079	DRIVE BASE 100 mm RIGHT	1
9	UAM1078	DRIVE BASE 100 mm LEFT	1

USM8110

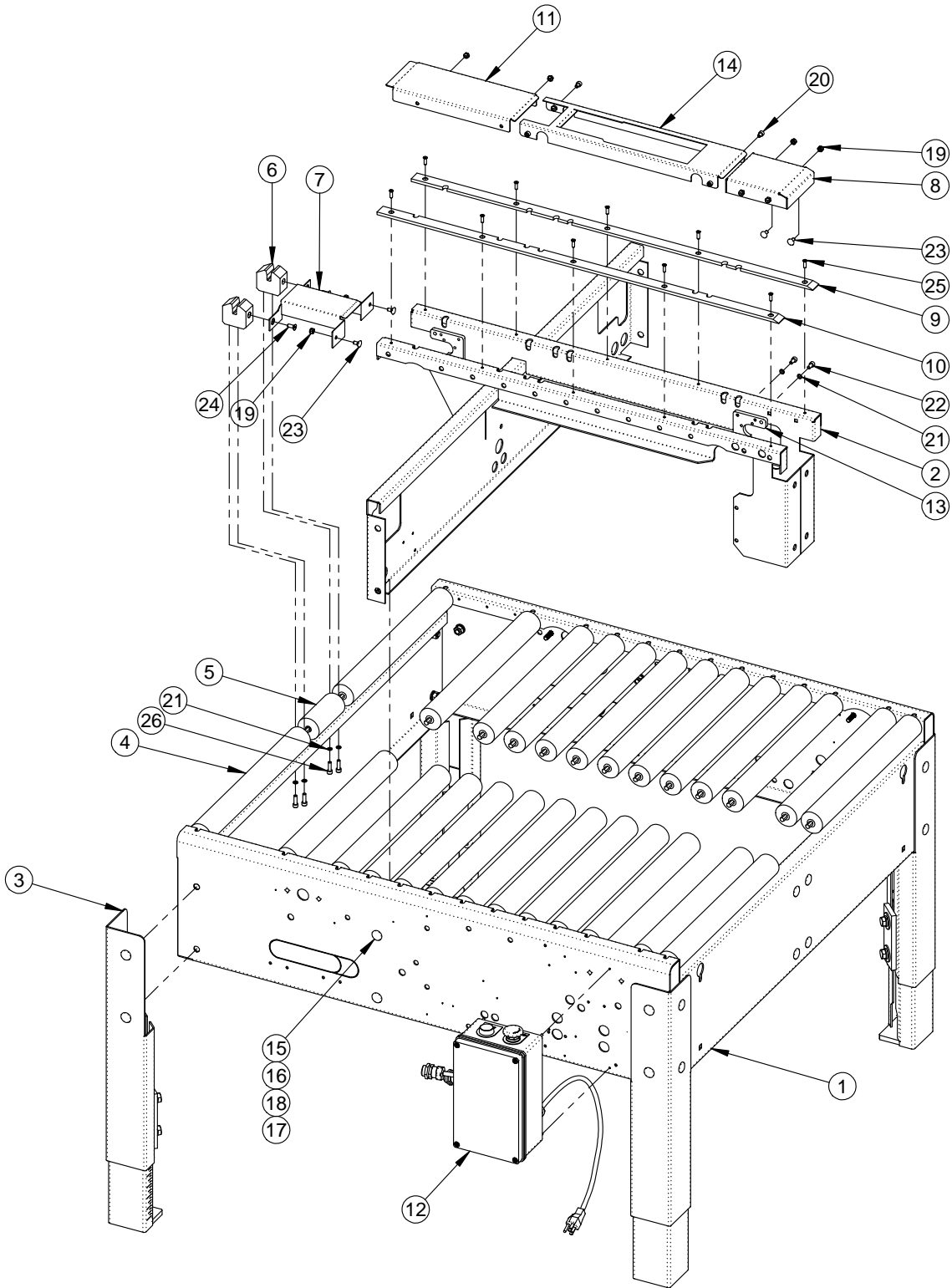

USM8110

ITEM NO.	PART NUMBER	DESCRIPTION	QTY.
1	UPM7632	BASE, MACHINE, 3036	1
2	UPM7633	TRANSVERSE BRACING 3036 SB	1
3	UAM0275	LEG ASSEMBLY METRIC	4
4	UPM7645	PVC ROLLER 3036 METRIC	26
5	UPM3227	PVC ROL CHARCOAL DIA 1.9 X 4.50	1
6	UPM3234EV	OUTLET ROLLER BLOCK	2
7	UPM3288EV	OUTLET COVER USA SB	1
8	UPM3229	INLET COVER	1
9	UPM0606EV	SLIDING PAD R.H.	1
10	UPM0609EV	SLIDING PAD L.H.	1
11	UPM4193	REAR GAP FILLER	1
12	USM0817	ELECTRICAL ASSEMBLY	1
13	UPM7625	FLANGE BEARING SPACER	2
14	UPM3815	T.H. INSERT 2"	1
15	UF4229	CARRIAGE BOLT M10-1.5 x 20	8
16	UF3680	FW M10	8
17	UF6371	LW M10	8
18	UF6314	HNR M10 x 1.5	8
19	UF5900	NYLON LOCK NUT M6-1.0	14
20	UF0810	SHCS M6-1 x 8	4
21	UF6363	LW M6	8
22	UF0820	SHCS M6-1 x 12	4
23	UF 3713	CARRIAGE BOLT M6 - 1 x 12	6
24	UF1192	FHCS M6-1 x 16 mm	2
25	UF4114	SELF TAPPING SCREW M5 X 16mm	10
26	UF0835	SHCS M6-1 X 20mm	4

UAM0275

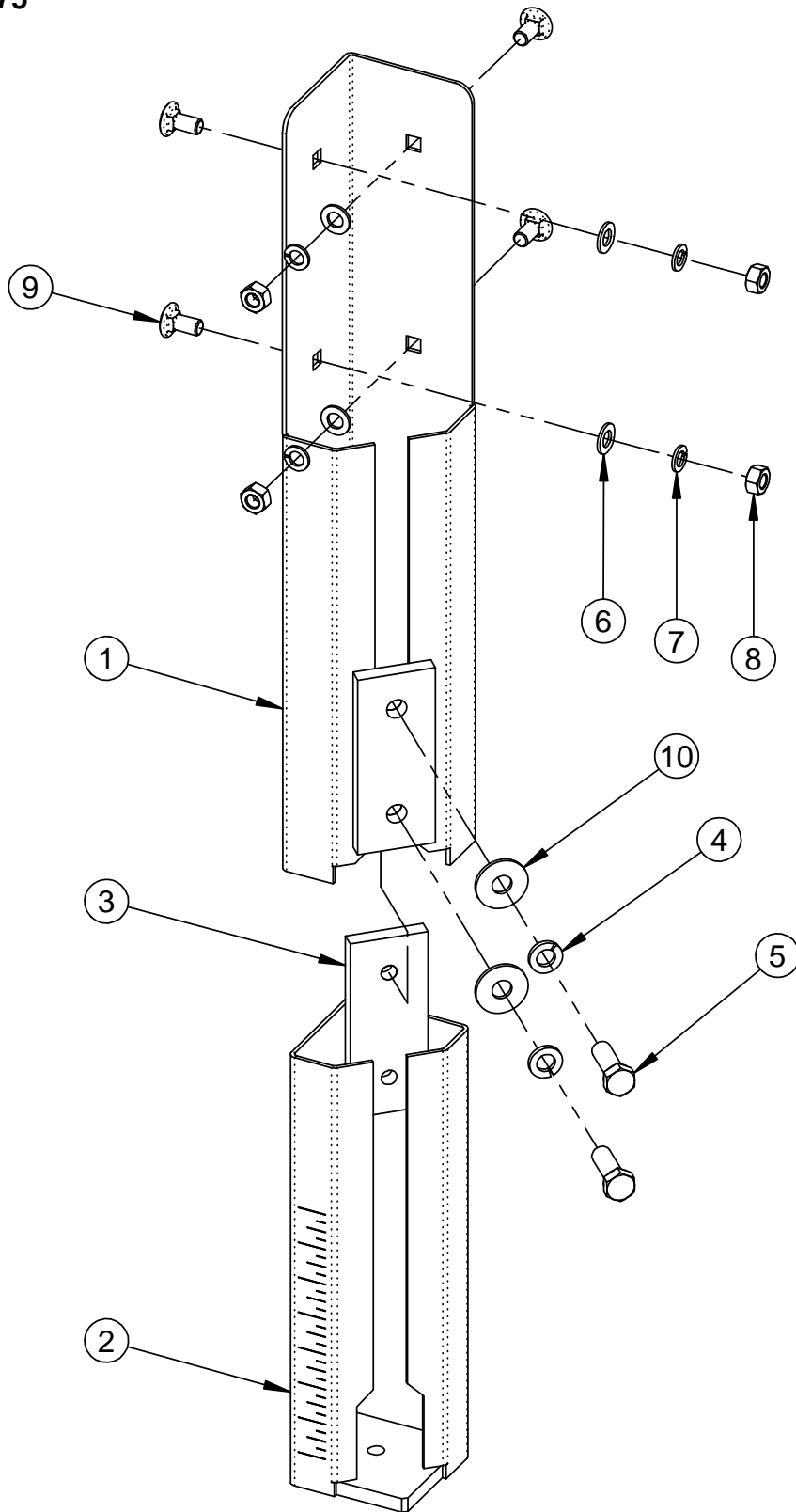

UAM0275

ITEM	PART #	DESCRIPTION	QTY.
1	UPM7640	LEG WELDMENT	1
2	UPM7641	LEG ADJUSTMENT	1
3	UPM7642	LEG FRICTION PLATE	1
4	UF4230	L.W. ZINC M12	2
5	UF6393	HHCSM12-1.75 x 35	2
6	UF3680	FW M10	4
7	UF6371	L.W. M10	4
8	UF6314	HNR M10 x 1.5	4
9	UF4229	CARRIAGE BOLT M10-1.5 x 20	4
10	UF4231	FW M12	2

USM0817

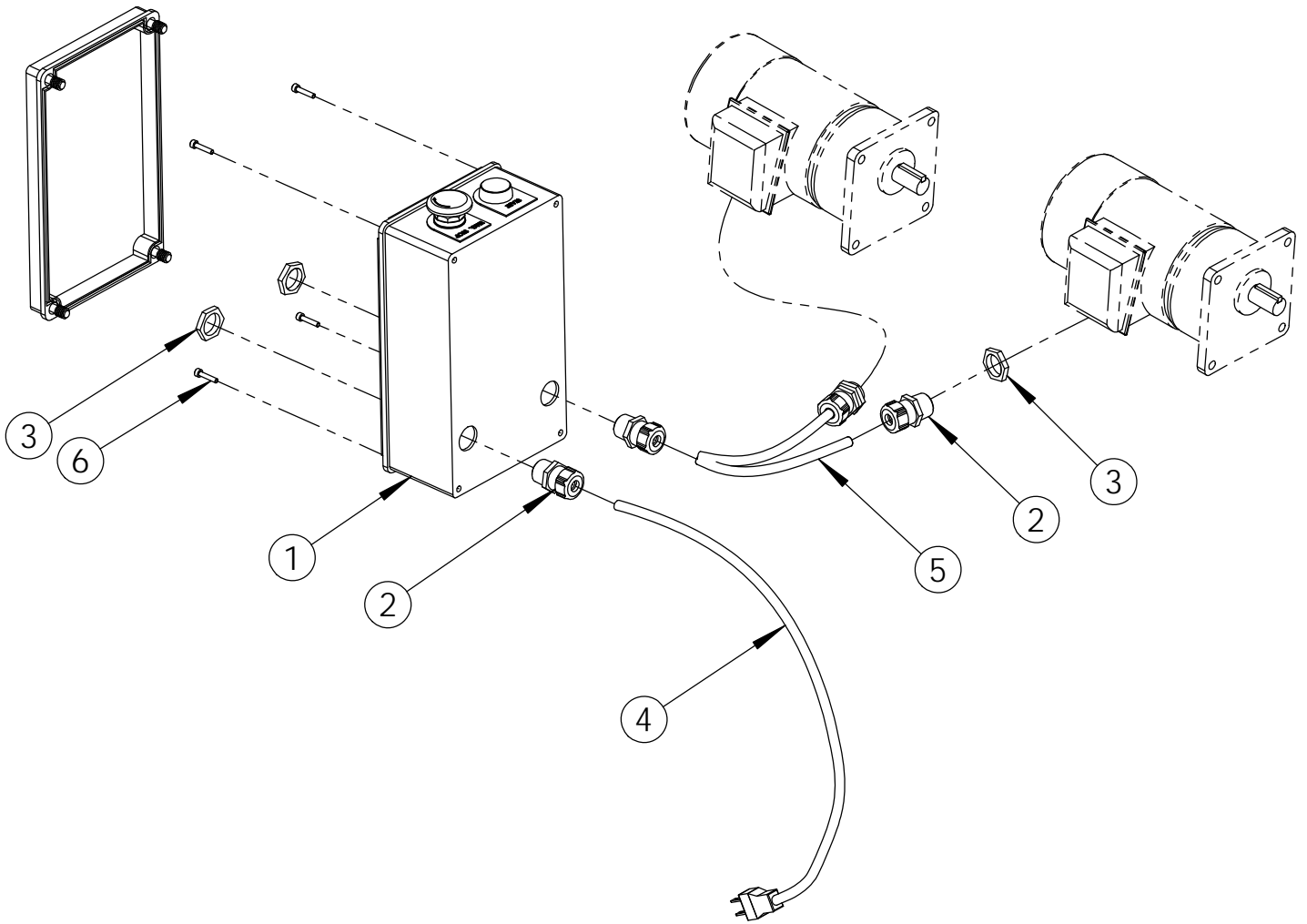

USM0817

ITEM	PART #	DESCRIPTION	QTY.
1	UAM0264	ELECTRIC BOX ASSEMBLY	1
2	UPM0197EV	STR.RELF METL.LIQDTGHT M20X1.5 (8-10mm)	4
3	UPM0341EV	LOCKNUT M20 X 1.5(FOR STRAIN RELF)	4
4	UPM0209	POWER CORD, 14/3	1
5	UPM0225	CABLE 18/3 TYPE SJ	2
6	UF3646	SHCS M4-0.7 x 20	4

UAM0264

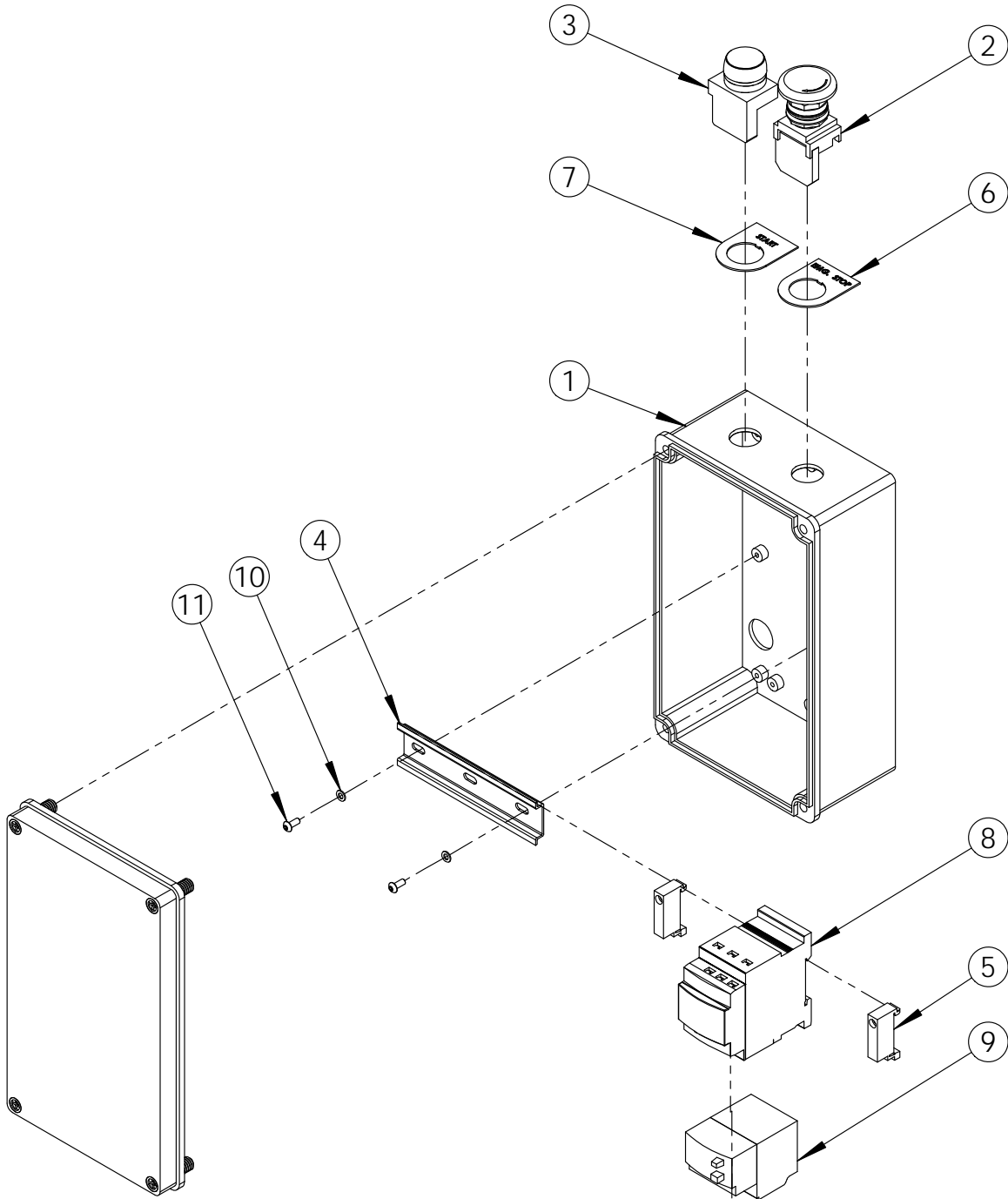

UAM0264

ITEM	PART #	DESCRIPTION	UAM0264/ QTY.
1	UPM7527	ENCLOSURE DEMEX HIBOX 132 X 232	1
2	UPM2211	BUTTON MUSHROOM 22mm 1 N.C.	1
3	UPM2212	BUTTON GREEN 22mm 1 N.O.	1
4	UPM0407EV	DIN RAIL USA 2324	1
5	UPM7440EV	TB END ANCHOR FOR DN SER	2
6	UPM2209EV	LEGEND PLATE "E-STOP"	1
7	UPM2210EV	LEGEND PLATE "START"	1
8	UPM7524	MOTOR STARTER TELEMEC 110VAC	1
9	UPM2213EV	MOTOR O/L TELEMEC 2.5-4.0A	1
10	UF3710	FW M4	2
11	UF6365	BHCS M4 x 0.7 x 10mm	2

USM8116

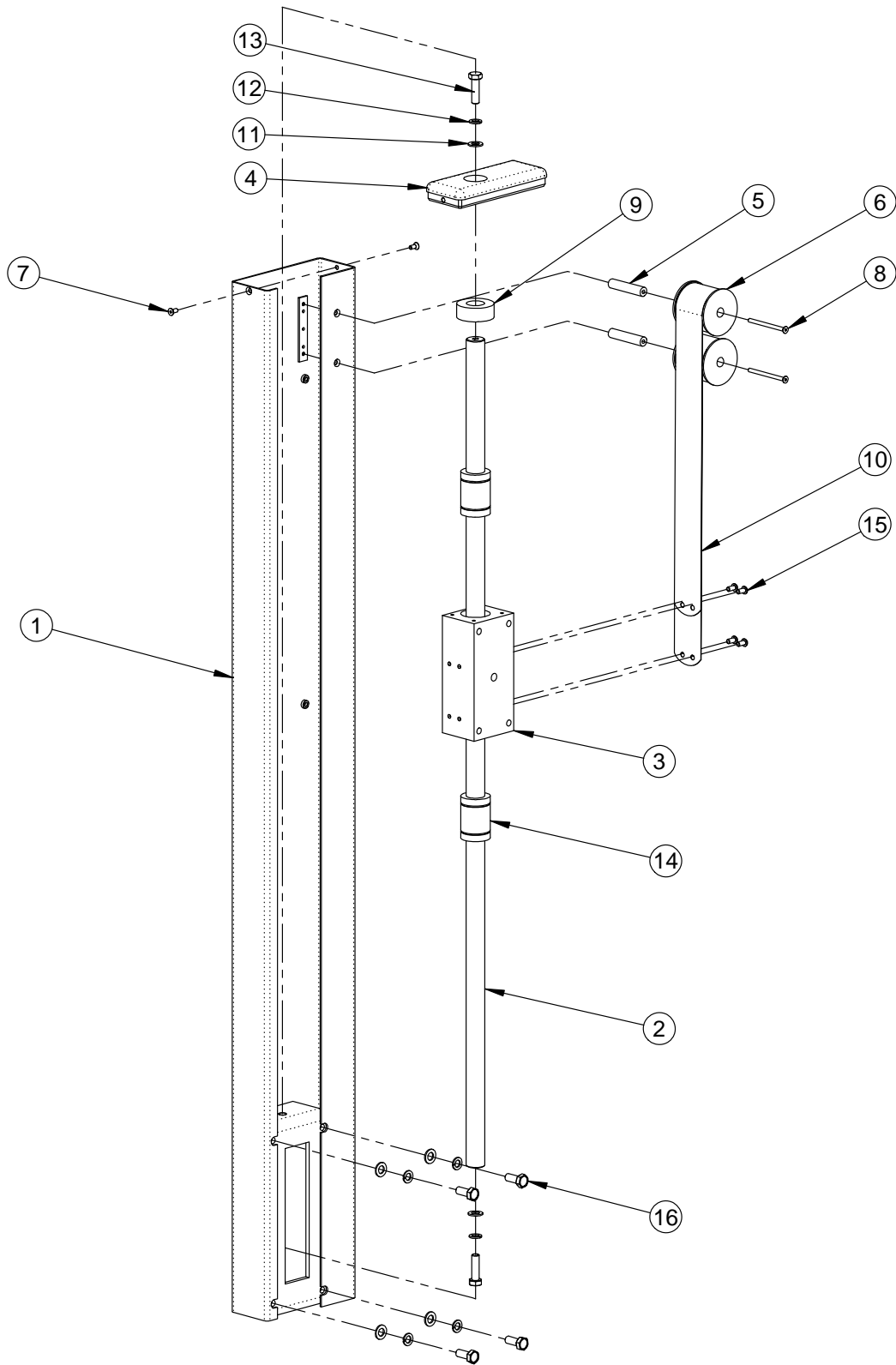

USM8116

ITEM	PART #	DESCRIPTION	QTY.
1	UPM9691	COLUMN 36 LEFT METRIC	1
2	UPM4522	COLUMN SHAFT	1
3	UPM9651	COLUMN BLOCK 40 mm BORE	1
4	UPM0741EV	COLUMN CAP LEFT SIDE	1
5	UPM0743	SPRING MANDREL SHAFT	2
6	UPM0742	SPRING SPOOL	2
7	UF5400	FHCSM5-0.8 x 12 mm	2
8	UF1157	FHCS M5-0.8 x 70	2
9	UPM2251	SAFETY BUMPER	1
10	UPM0740	CONSTANT FORCE SPRING	2
11	UF3680	FW M10	6
12	UF6371	L.W. M10	6
13	UF0301	HHCSM10-1.5 x 35	2
14	LM 25UU	LINEAR BEARING 25 mm	2
15	UF1195	BHCSM6-1 x 12 mm	4
16	UF6382	HHCSM10-1.5 x 25 mm	4

USM8117

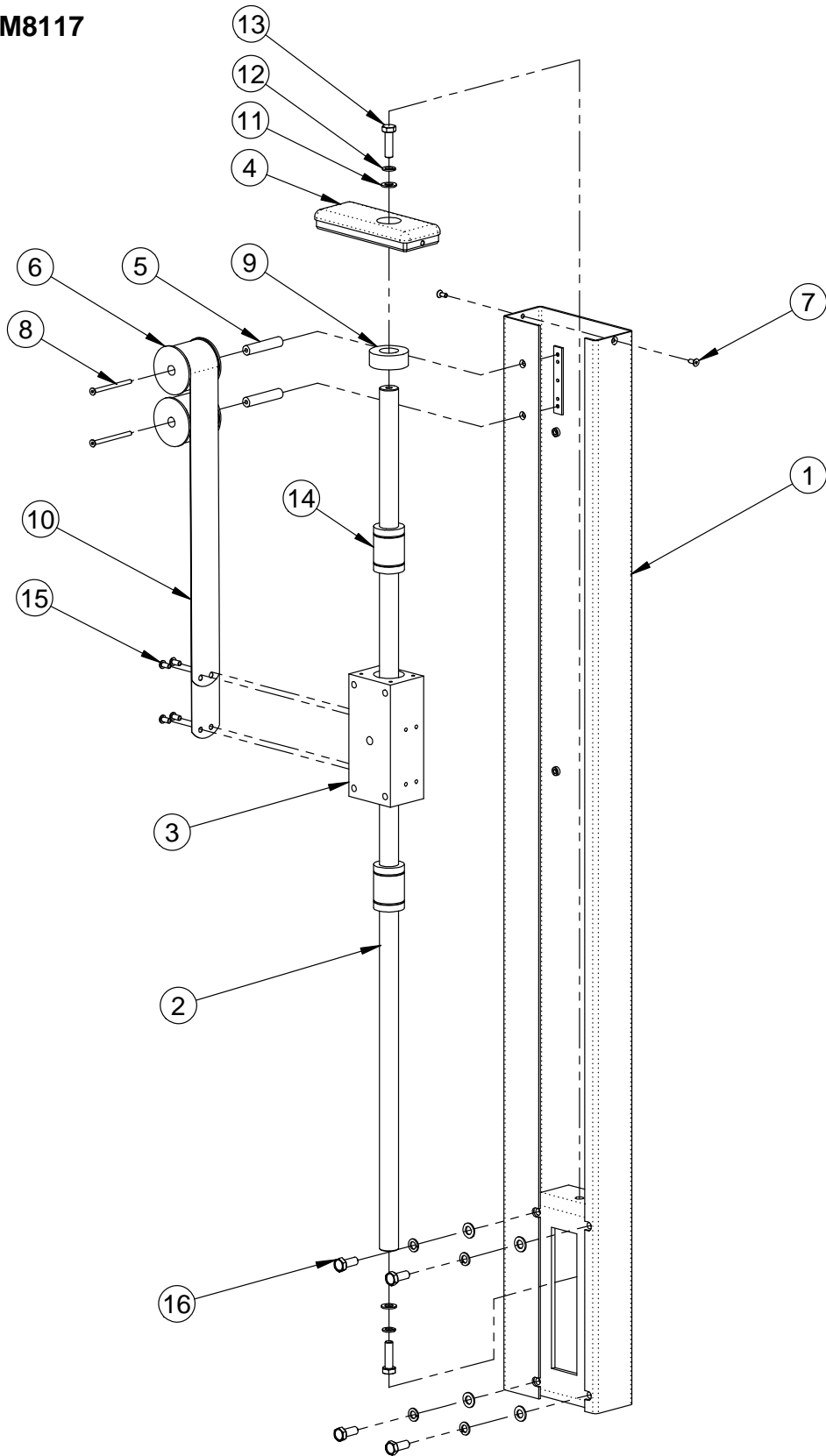

USM8117

ITEM	PART #	DESCRIPTION	QTY.
1	UPM9692	COLUMN 36 RIGHT METRIC	1
2	UPM4522	COLUMN SHAFT	1
3	UPM9651	COLUMN BLOCK 40 mm BORE	1
4	UPM2182EV	COLUMN CAP RIGHT SIDE	1
5	UPM0743	SPRING MANDREL SHAFT	2
6	UPM0742	SPRING SPOOL	2
7	UF5400	FHCSM5-0.8 x 12 mm	2
8	UF1157	FHCS M5-0.8 x 70	2
9	UPM2251	SAFETY BUMPER	1
10	UPM0740	CONSTANT FORCE SPRING	2
11	UF3680	FW M10	6
12	UF6371	L.W. M10	6
13	UF0301	HHCSM10-1.5 x 35	2
14	LM 25UU	LINEAR BEARING 25 mm	2
15	UF1195	BHCSM6-1 x 12 mm	4
16	UF6382	HHCSM10-1.5 x 25 mm	4

USM7564

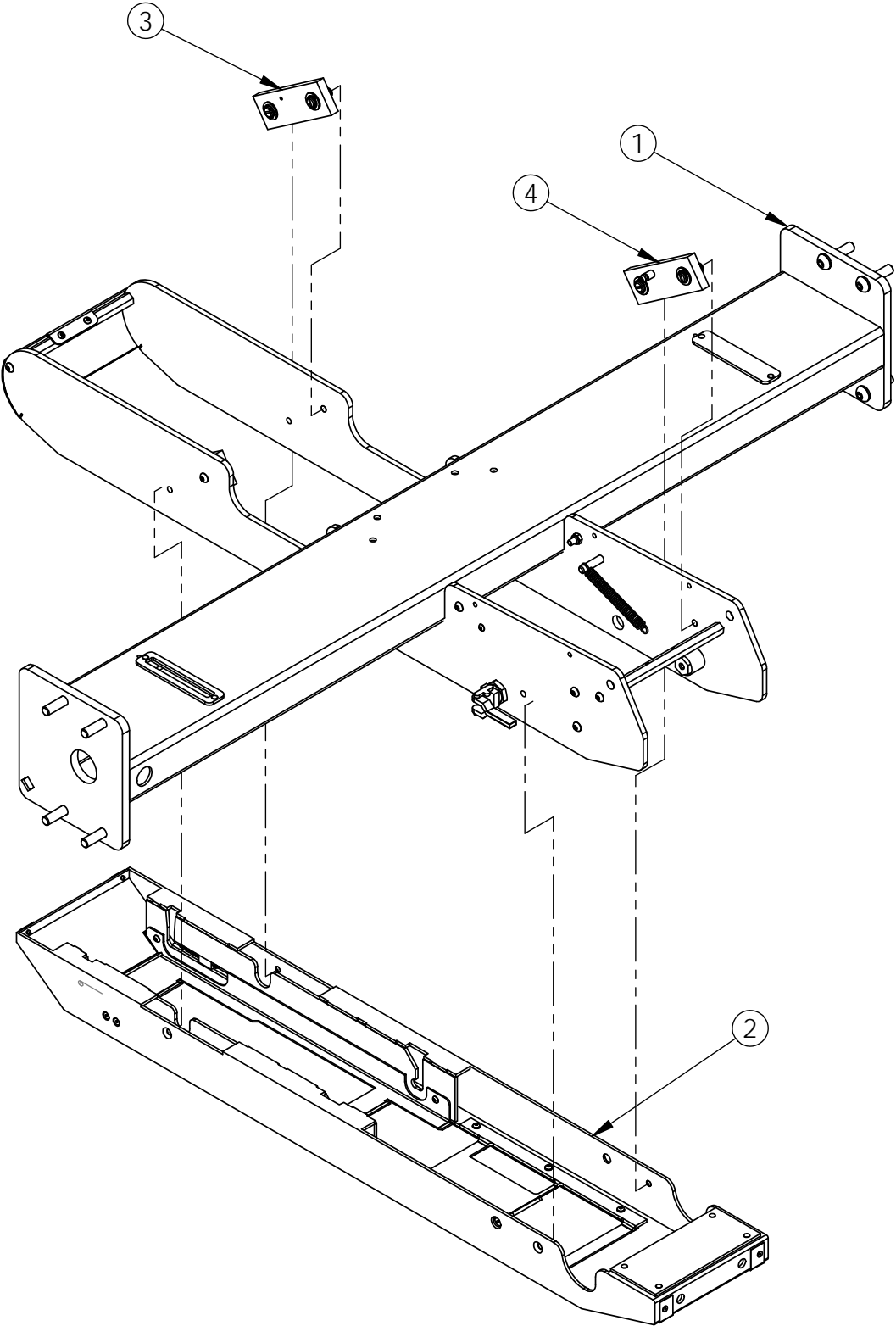

USM7564

ITEM	PART #	DESCRIPTION	QTY.
1	UAM0276	BRIDGE SUB-ASSEMBLY 3036 SB	1
2	UAM0325	TAPEHEAD BOX USA 3036 SB	1
3	UAM0296	PIVOT ASS'Y	2
4	UAM0297	PIVOT ASS'Y	2

UAM0276

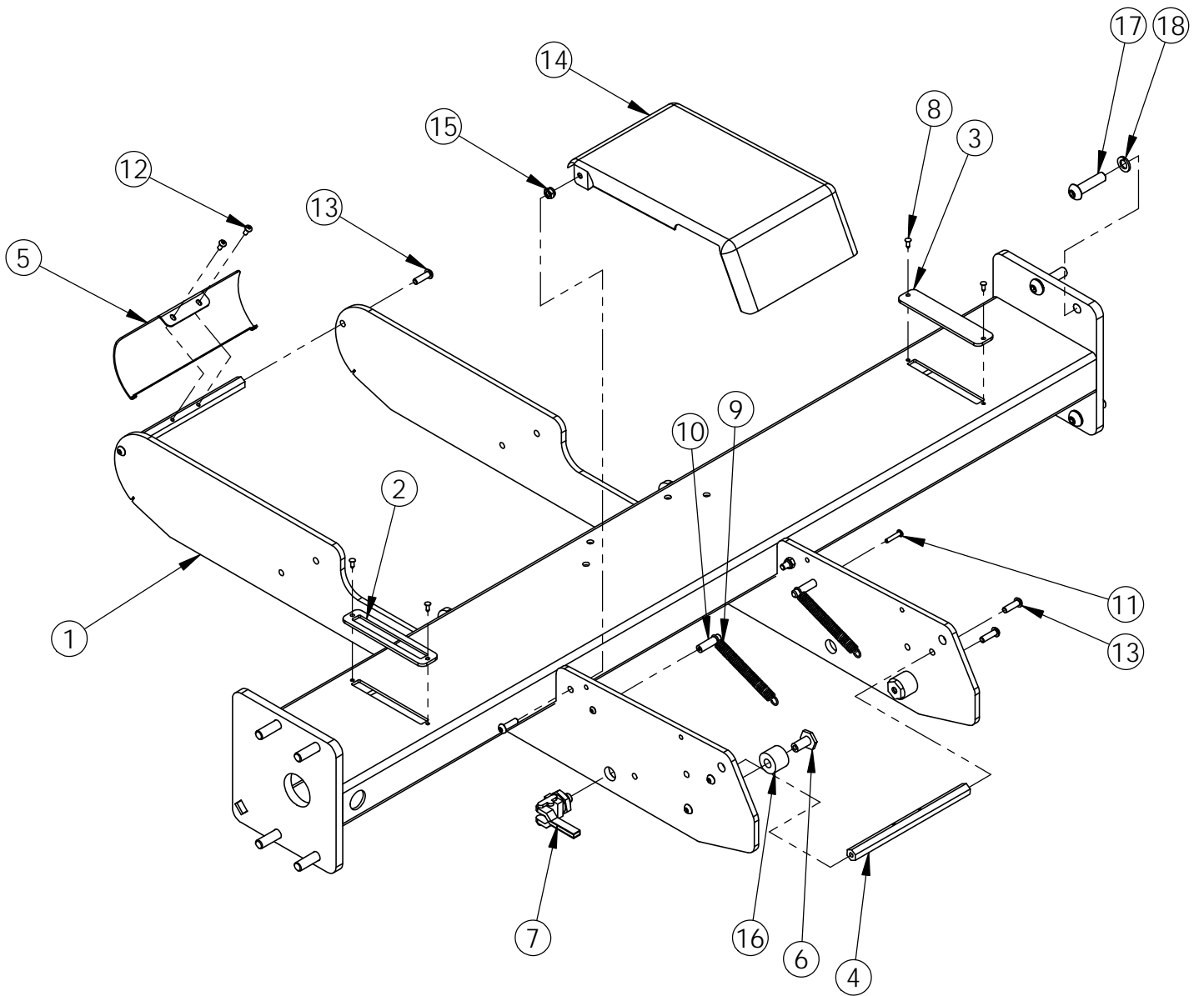

UAM0276

ITEM	PART #	DESCRIPTION	QTY.
1	UPM9654	BRIDGE 3036 SB	1
2	UPM1011	BRIDGE PLATE COVER SLOTTED	1
3	UPM1008	BRIDGE PLATE COVER	1
4	UPM3360EV	HEX SPACER BAR	2
5	UPM3292	REAR COVER GUARDING	1
6	UPM2168EV	STOP RETAINER TH BOX	2
7	UPM2196	TOGGLE CLAMP	1
8	UPM2192	BLACK PLUG	4
9	UPM1042	EXTENSION SPRING	2
10	UPM0967EV	SPRING RETAINER LONG	2
11	UF4050EV	BHCS M4 - 0.7 x 20	2
12	UF6365	BHCS M4 x 0.7 x 10mm	2
13	UF1241EV	BHCS M6-1 x 20	8
14	UPM2284EV	FRONT COVER	1
15	UF5900	NYLON LOCK NUT M6-1.0	2
16	UPM4449	FLOATING THB STOP	2
17	UF6384	BHCS M10-1.5 x 40	8
18	UF6371	L.W. M10	8

UAM0325

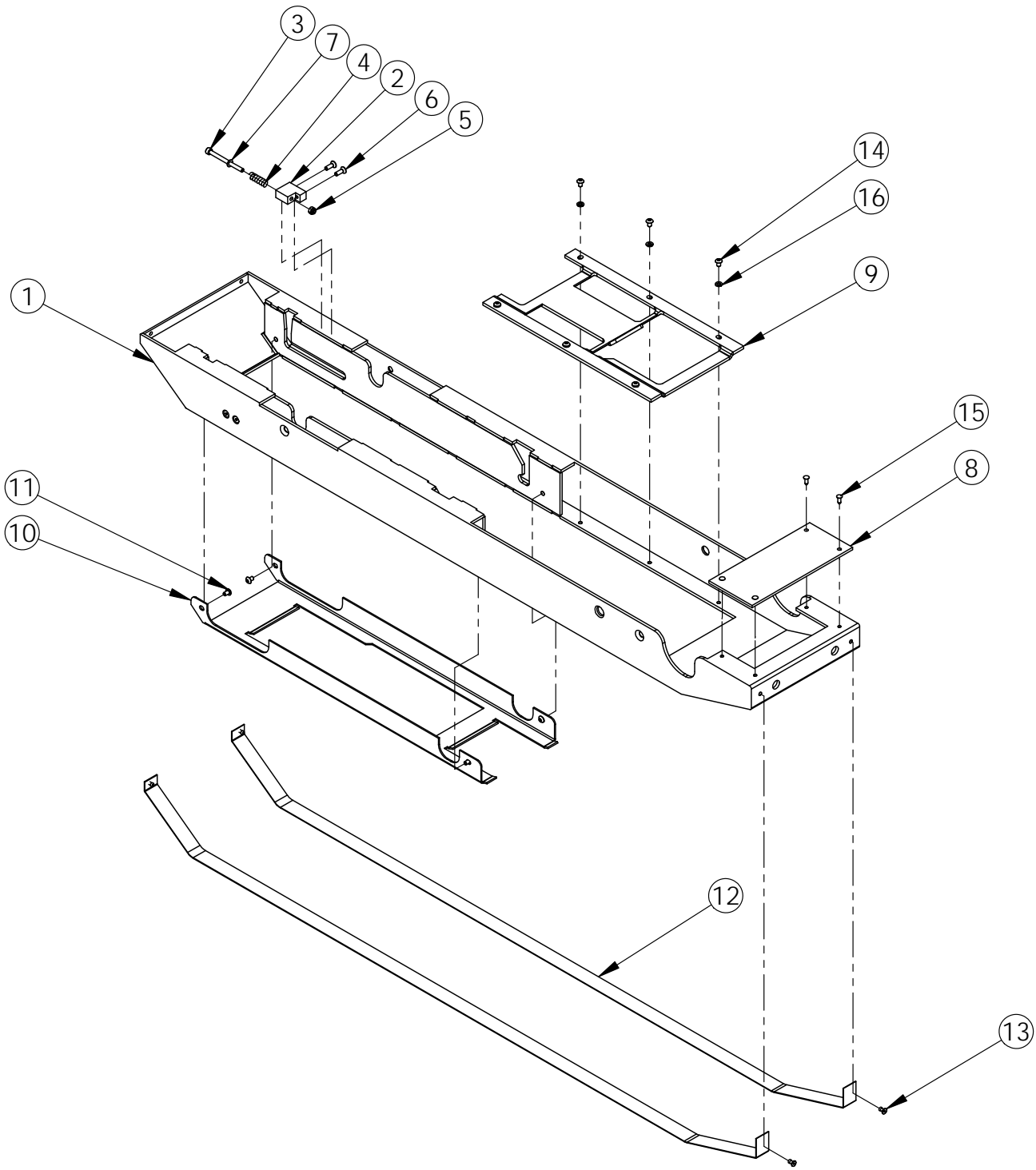

UAM0325

ITEM	PART #	DESCRIPTION	QTY.
1	UPM2520EV	TH BOX WELDMENT USA SB	1
2	UPM7541	SPRING SUPPORT M4	2
3	UF6375	SHCS M4-0.7 x 50mm	2
4	UPM1068	COMP.SPRING SWIVEL T.H. ASSY	2
5	UF6376	NYLON LOCKNUT M4	2
6	UF3714	FHCS M4-0.7 x 12mm	4
7	UF3710	FW M4	2
8	UPM3679	FRONT PLATE GUARDING	1
9	UPM9655	TOP FILLER ET Metric	1
10	UPM3246	ET T.H. TOP GAP FILLER	1
11	UF7008	SS BHCS M4-07 X 6mm	4
12	UPM0029	STRIP, UHMW, 2" W X .03" THK	2
13	UF2080	POP RIVET S-44	4
14	UF6374	BHCS M4-0.7 x 6 mm	6
15	UPM2192	BLACK PLUG	4
16	UF3681	L.W. M4	6

UAM0296
UAM0297

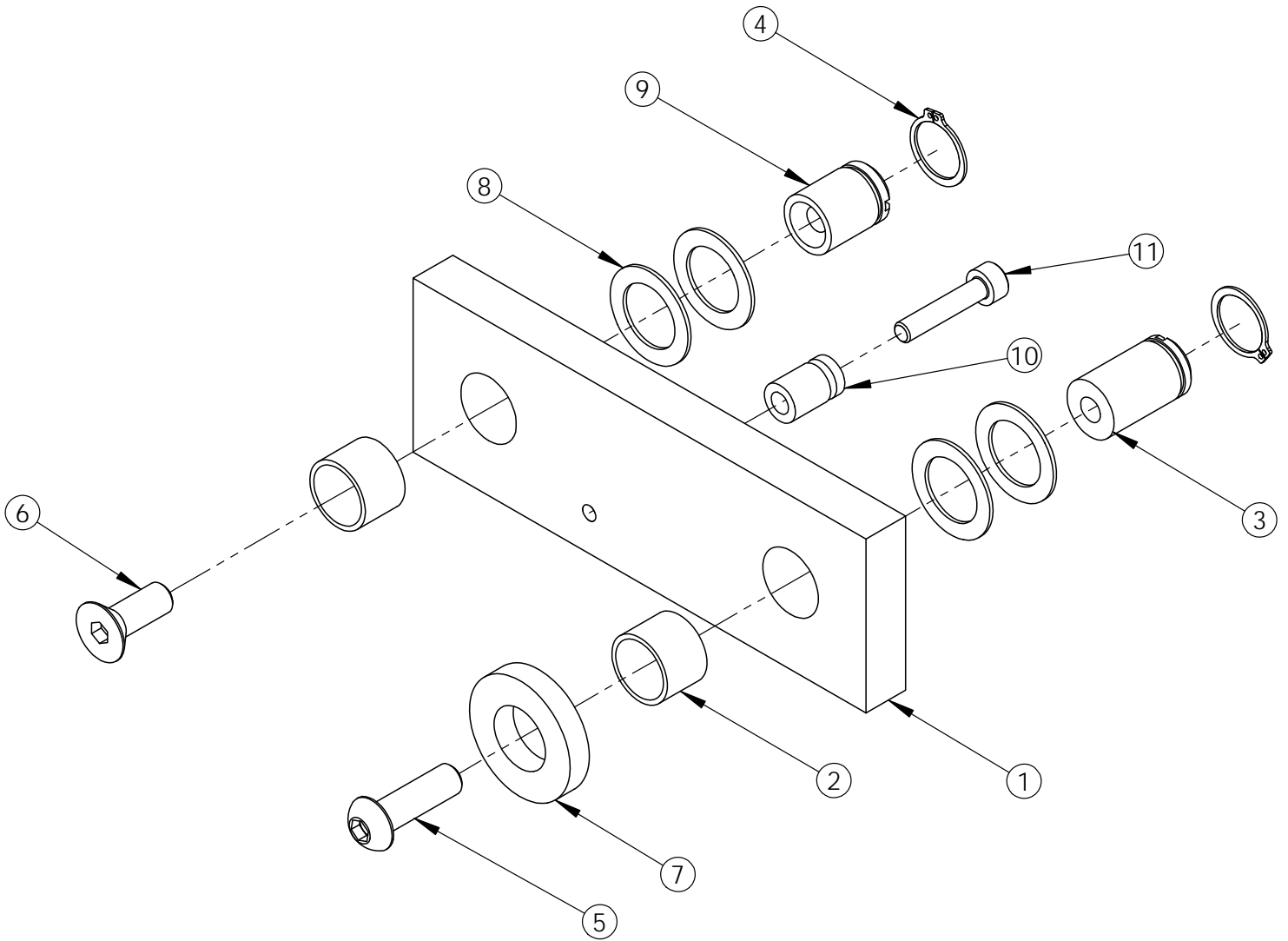

UAM0296
UAM0297

ITEM	PART #	DESCRIPTION	UAM0297/QTY.	UAM0296/QTY.
1	UPM1130EV	PIVOT PLATE REAR	1	1
2	UPM9075	BEARING PERMAGLIDE 12 X 14 X 10	2	2
3	UPM0968EV	PIVOT SHAFT LONG T.H. BOX 222	1	1
4	UF6300	RETAINING RING FOR 12mm SHAFT	2	2
5	UF1241EV	BHCS M6-1 x 20	1	1
6	UF1192	FHCS M6-1 x 16 mm	1	1
7	UPM1158	PIVOT SHAFT SPACER	1	1
8	UF1940	F.W. NYLON 1/2IDx.772ODx.032TH	4	4
9	UPM2247EV	PIVOT SHAFT SHORT T.H. BOX 222	1	1
10	UPM0962EV	SPRING RETAINER	1	-
11	UF3646	SHCS M4-0.7 x 20	1	-

USM8114

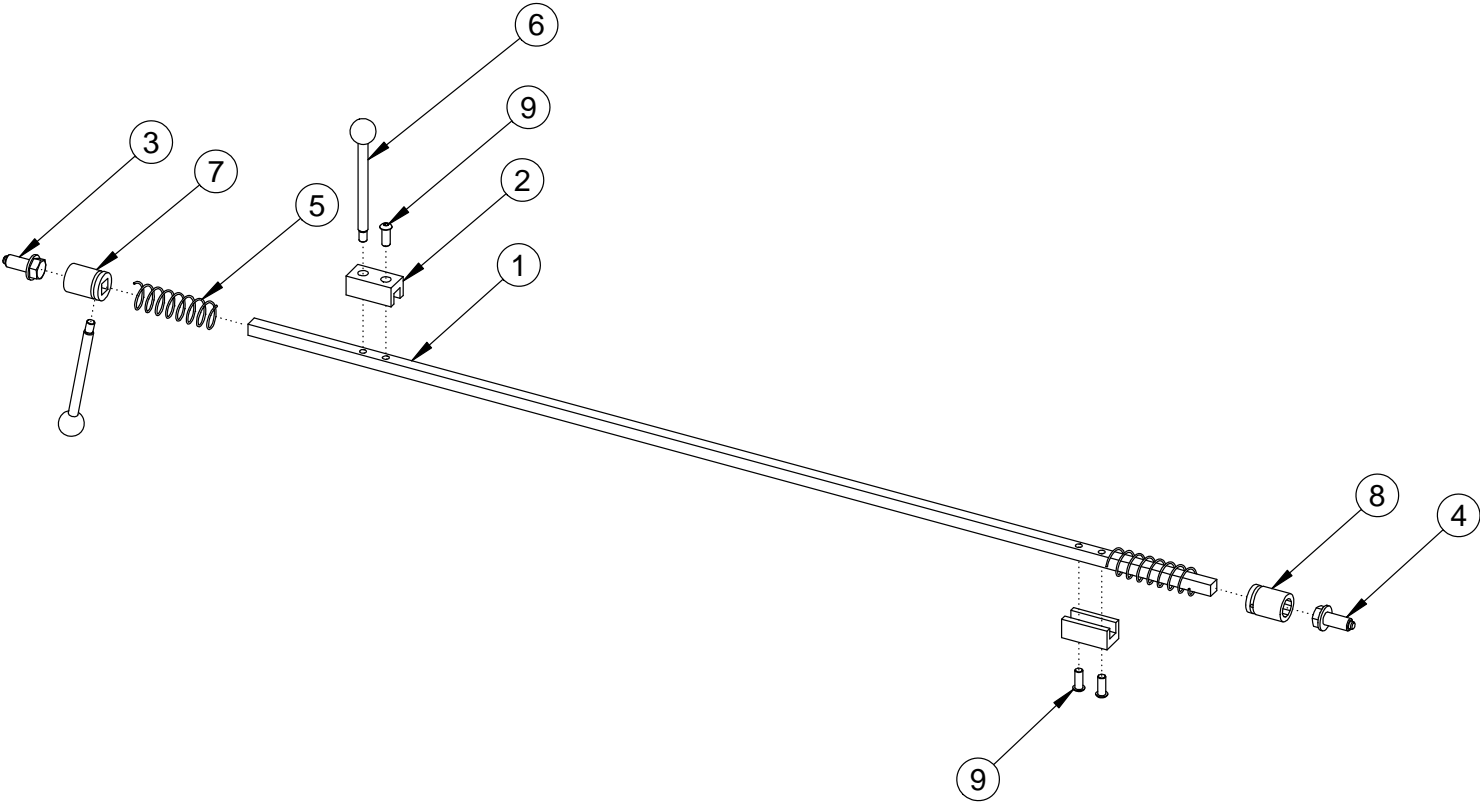

USM8114

ITEM	PART #	DESCRIPTION	QTY.
1	UPM9657	SINGLE LOCK BAR 3036	1
2	UPM9663	SINGLE LOCK BLOCK	2
3	UPM0698	FLANGED SCREW 1/2-13 L.H.	1
4	UPM0699	FLANGED SCREW 1/2-13 R.H.	1
5	UPM2184	SPRING, C1100-065-4000-M	2
6	UPM0688EV	SINGLE LOCKING HANDLE	2
7	UPE0119	MODIFIED SHORT SOCKET 3/4"	1
8	UPM0703	SHORT BOX 3/4", 1/2" DR, 12 PT	1
9	UF1318	BHCS M8-1.25 x 20mm	3

UAM0260

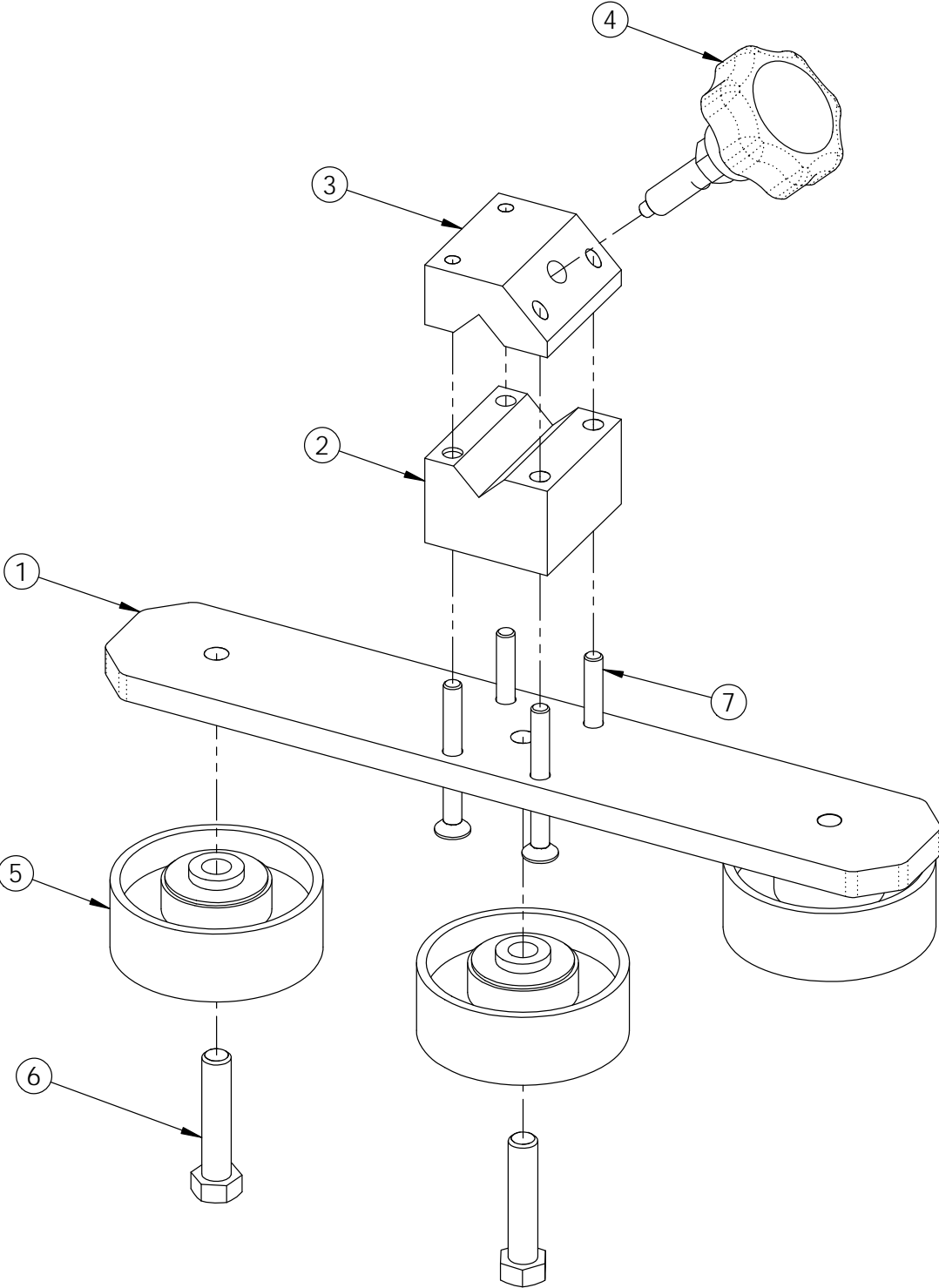

UAM0260

ITEM	PART #	DESCRIPTION	QTY.
1	UPM7491	WHEEL SUPPORT PLATE	1
2	UPM3285EV	GUIDE BLOCK	1
3	UPM7538EV	GUIDE BLOCK TOP	1
4	UAM0288	KNOB CW 5mm PIN USA2324	1
5	UPM1659	WHEEL 2-7/8"DIA.COMPR.GUIDE	3
6	UF0240	HHCS 3/8-16 x 1.75	3
7	UF6373	FHCS M6 - 1 x 55	4

USM8113

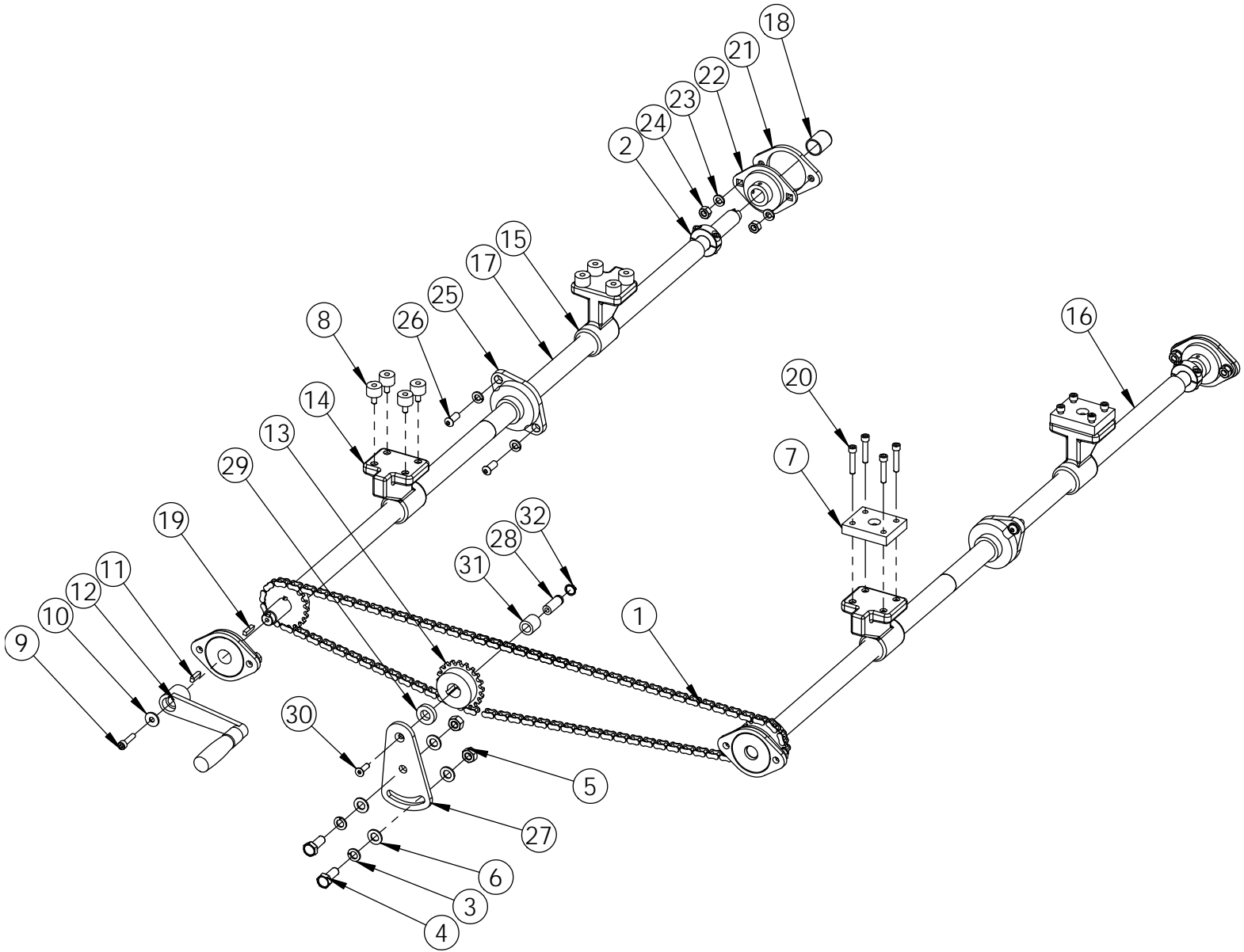

USM8113

ITEM	PART #	DESCRIPTION	QTY.
1	UPM0618	CHAIN #35-165 PITCH	1
2	UPM7583	SHAFT COLLAR	2
3	UF6371	L.W. M10	2
4	UF6382	HHCSM10-1.5 x 25 mm	2
5	UF6314	HNR M10 x 1.5	2
6	UF3680	FW M10	4
7	UPM3242	DRIVE SUPPORT SPACER	2
8	UPM0576	BUMPER	8
9	UF0840	SHCSM6-1 X 25mm	1
10	UF1828	REG F.W. M6	1
11	UF2210EV	SQUARE KEY ROUND ENDS 5 X 5 X 20	1
12	UPE0001EV	CRANK HANDLE, FOLDABLE	1
13	UPM0620	SPROCKET 35B20.75ID C/W 3/16 KW	3
14	UPM0575EV	CASTING LH	2
15	UPM0574EV	CASTING RH	2
16	UPM9666	ACME SHAFT SHORT USA3036	1
17	UPM9665	ACME CRANK SHAFT USA3036	1
18	UPM2207	CAP VINYL BLACK	1
19	UF2210	SQUARE KEY, ZINC .188 x .188 x .75	2
20	UF0640	SHCSHK 1/4-20 X 1-1/4"	8
21	UPM2198	BEARING SPACER	4
22	UPM0523EV	FLANGE BEARING	4
23	UF0867	LW M8	12
24	UF0866	HNR M8-1.25	8
25	UPM9687	FLANGE BEARING 1" DIA	2
26	UF1318	BHCSM8-1.25 x 20 mm	4
27	UPM0631EV	TENSIONNER BRACKET	1
28	UPM0640EV	TENSIONNER PIN	1
29	UPM0641	CHAIN TENSIONNER SPACER	1
30	UF5402	FHCSM6 - 1 x 20	1
31	UPM0639EV	SLEEVE BEARING 12 mmID 3/4OD 3/4LG	1
32	UF2170	1/2" RETAINING RING	1

UAM1079

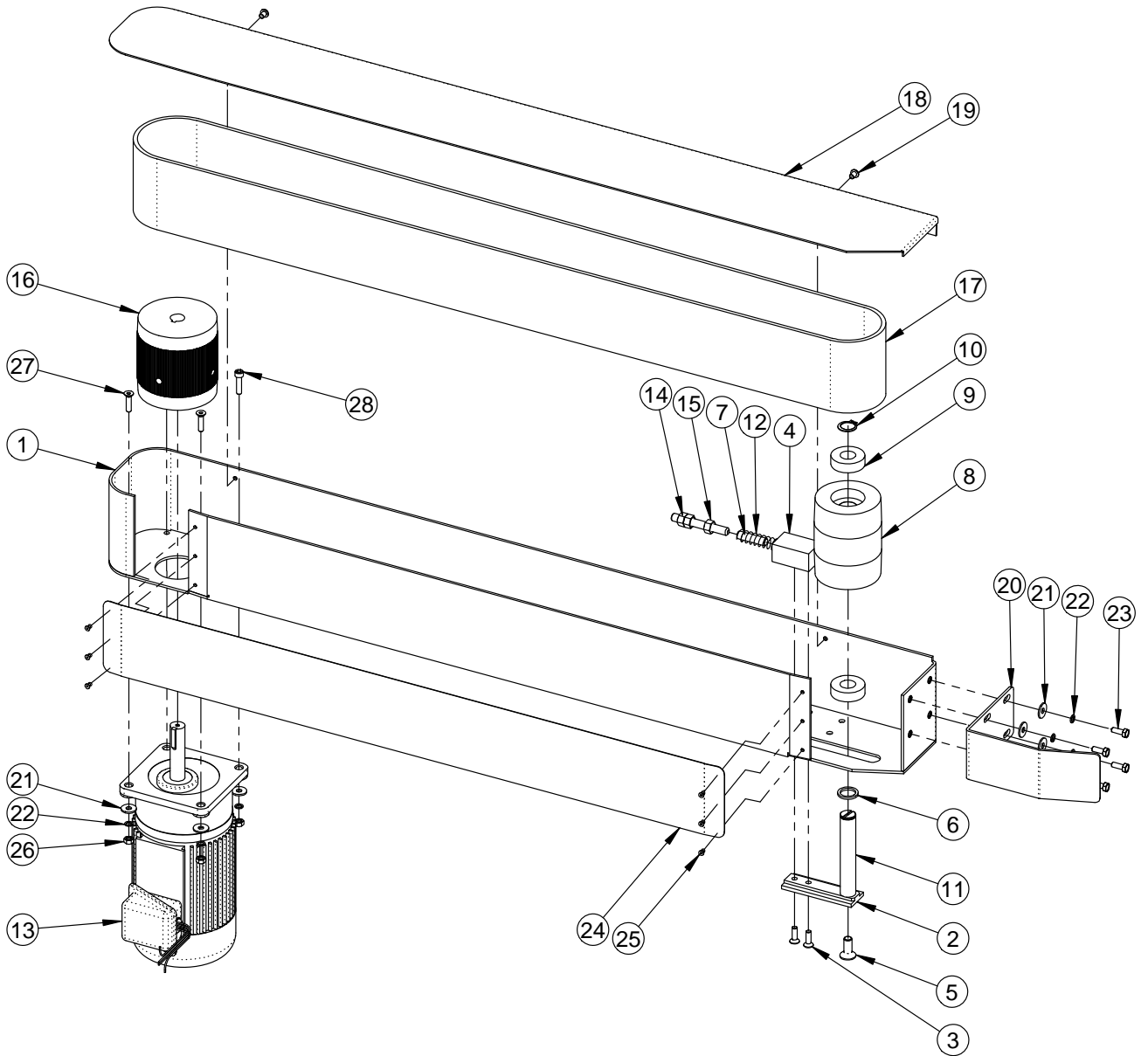

UAM1079

ITEM	PART #	DESCRIPTION	QTY.
1	UPM9673	DRIVE SECTION RIGHT 100 mm	1
2	UPM1879EV	TENSIONNER SLIDE	1
3	UF5402	FHCSM6 - 1 x 20	2
4	UPM0101EV	TENSIONNER SPRING HOLDER	1
5	UF1191	FHCSM10-1.5 x 25	1
6	UPM0109	IDLER PULLEY SPACER	1
7	UPM0112	SPRING LOCATOR PIN	1
8	UPM0392	IDLER PULLEY	1
9	UPM0324	BEARING, PULLEY	2
10	UF2220	SNAP RING (MEDAL) SH0075PA	1
11	UPM0393EV	IDLER PULLEY SHAFT 100mm	1
12	UPM0038	DIE SPRING (DRIVE BASE)	1
13	UPM7152	1/3 HP 110V MOTOR, LONG SHAFT	1
14	UF1400	SSSHK 3/8-16 X 3	1
15	UF1540	HNR 3/8-16	3
16	UPM9681	DRIVE PULLEY 100mm	1
17	UPM2565	BELT ENDLESS 100 x 2120mm	1
18	UPM9688	DRIVE COVER METRIC RIGHT	1
19	UF1206	BHCSM6-1 X 8mm	2
20	UPM9690	BOX GUIDE	1
21	UF1828	REG F.W. M6	8
22	UF6363	LW M6	8
23	UF0454	M6-1.0 X 16mm HHCS	4
24	UPM9686	STRIP UHMW 100 W, 850 L, 0.8 T	1
25	UF2080	POP RIVET S44	6
26	UF3637	HNR M6-1.0	4
27	UF1194	FHCSM6 - 1 x 25 mm	2
28	UF0840	SHCSM6-1 X 25mm	2

UAM1078

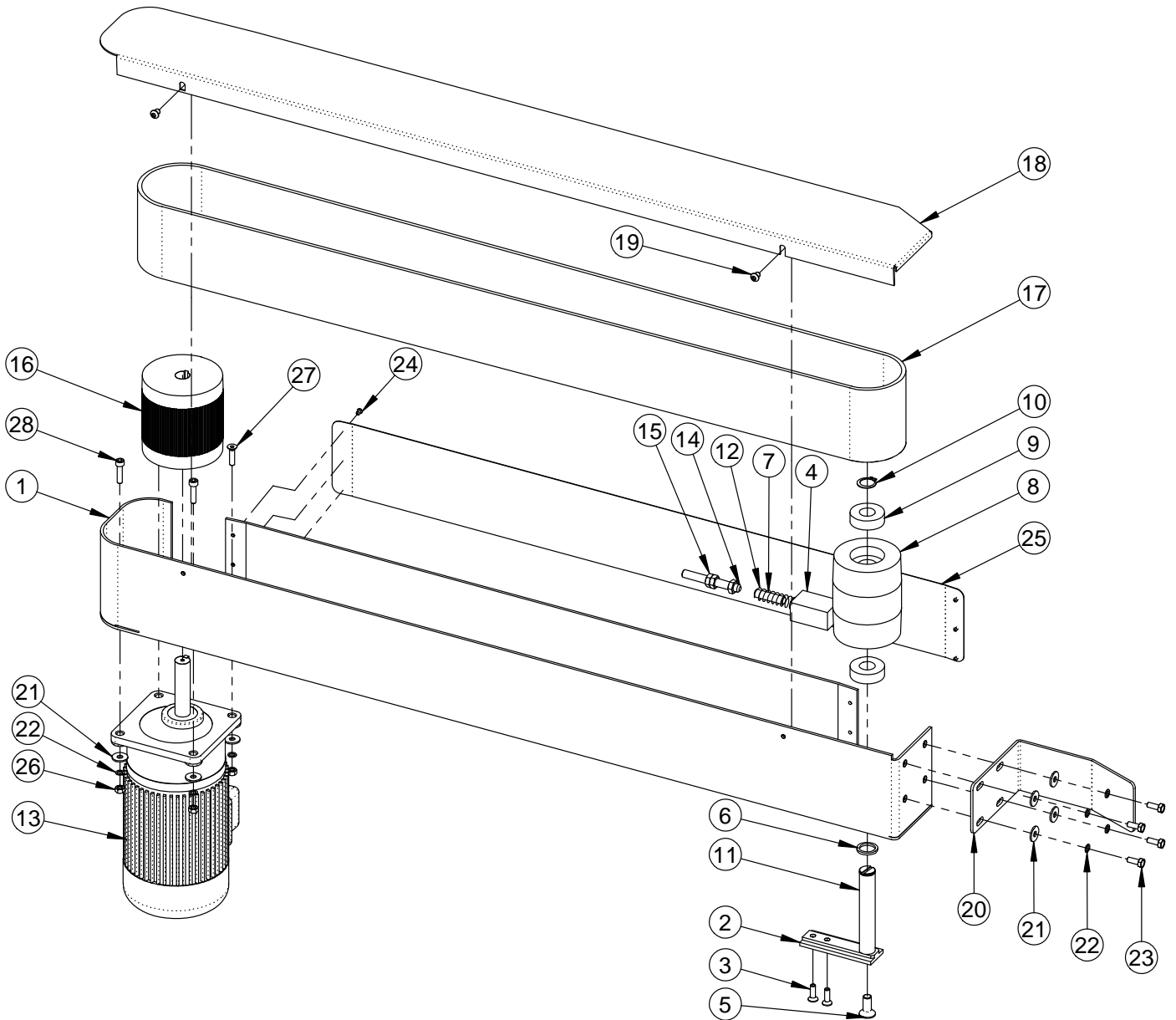

UAM1078

ITEM	PART #	DESCRIPTION	QTY.
1	UPM9674	DRIVE SECTION LEFT	1
2	UPM1879EV	TENSIONNER SLIDE	1
3	UF5402	FHCSM6 - 1 x 20	2
4	UPM0101EV	TENSIONNER SPRING HOLDER	1
5	UF1191	FHCSM10-1.5 x 25	1
6	UPM0109	IDLER PULLEY SPACER	1
7	UPM0112	SPRING LOCATOR PIN	1
8	UPM0392	IDLER PULLEY	1
9	UPM0324	BEARING, PULLEY	2
10	UF2220	SNAP RING (MEDAL) SH0075PA	1
11	UPM0393EV	IDLER PULLEY SHAFT 100mm	1
12	UPM0038	DIE SPRING (DRIVE BASE)	1
13	UPM7152	1/3 HP 110V MOTOR, LONG SHAFT	1
14	UF1400	SSSHK 3/8-16 X 3	1
15	UF1610	HNJ3/8-16	3
16	UPM9681	DRIVE PULLEY 100mm	1
17	UPM2565	BELT ENDLESS 100 x 2120mm	1
18	UPM9689	DRIVE COVER METRIC LEFT	1
19	UF1206	BHCSM6-1 X 8mm	2
20	UPM9690	BOX GUIDE	1
21	UF1828	REG F.W. M6	8
22	UF6363	LW M6	8
23	UF0454	M6-1.0 X 16mm HHCS	4
24	UF2080	POP RIVET S-44	6
25	UPM9686	STRIP UHMW 100 W, 850 L, 0.8 T	1
26	UF3637	HNR M6-1.0	4
27	UF1194	FHCSM6 - 1 x 25 mm	2
28	UF3180	SSSHCS M6-1 X 25mm	2

UM9003

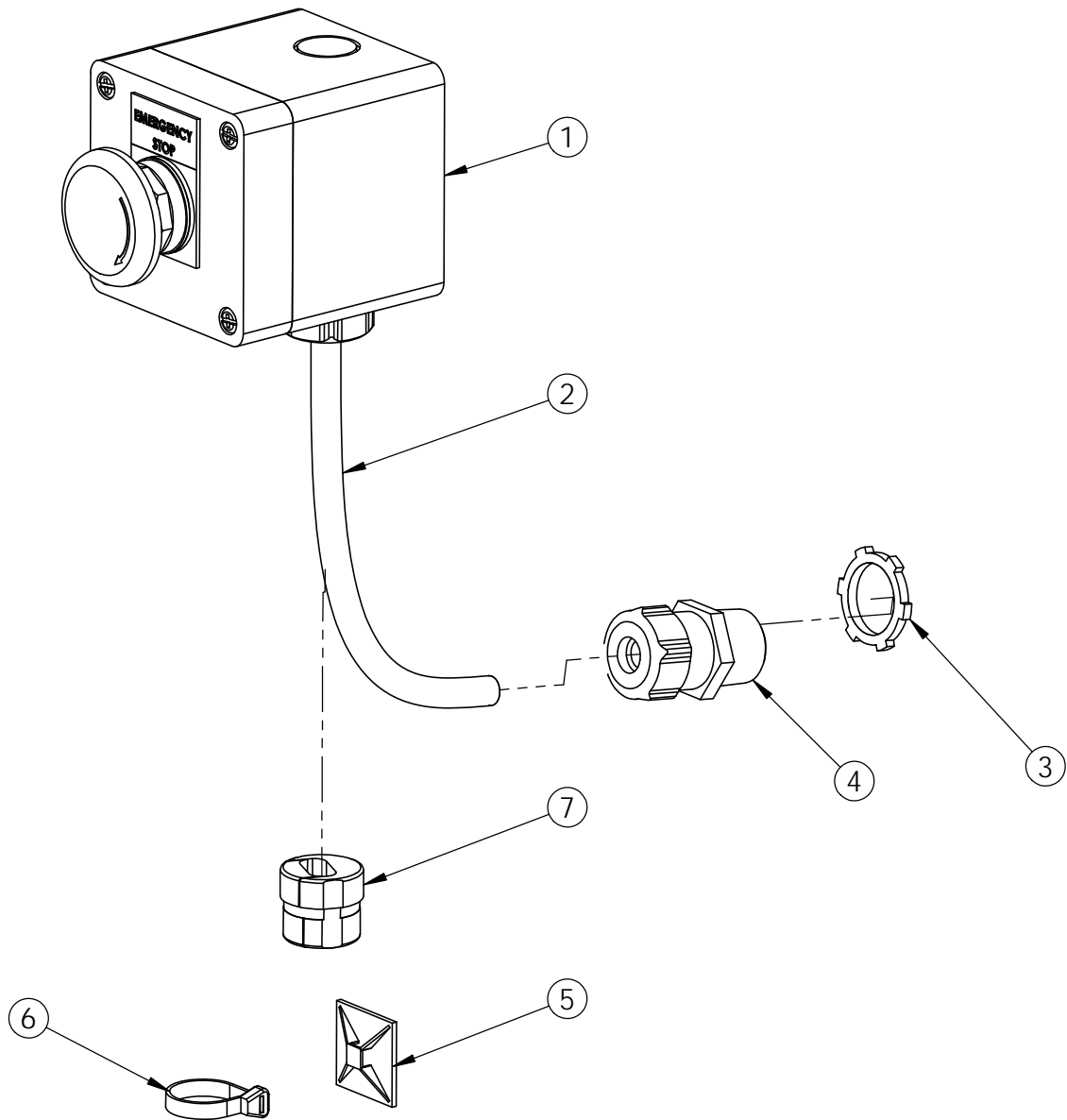

UM9003

ITEM	PART #	DESCRIPTION	QTY.
1	USM8075	SECOND E-STOP BOX FOR USA	1
2	UPM0225	CABLE 18/3 TYPE SJ	1
3	UPM0341	LOCKNUT 1/2"(FOR STRAIN RELF)	1
4	UPM0197	STR.RELF METL.LIQDTGHT 1/4-3/8	1
5	UPM0200	MTG. CLAMP,ADH.1.2"X1.2"	1
6	UPM0222	TY-RAP,5.5"X.14"	1
7	UPM0285	STRAIN RELIEF, NON-METAL	1

USM8075

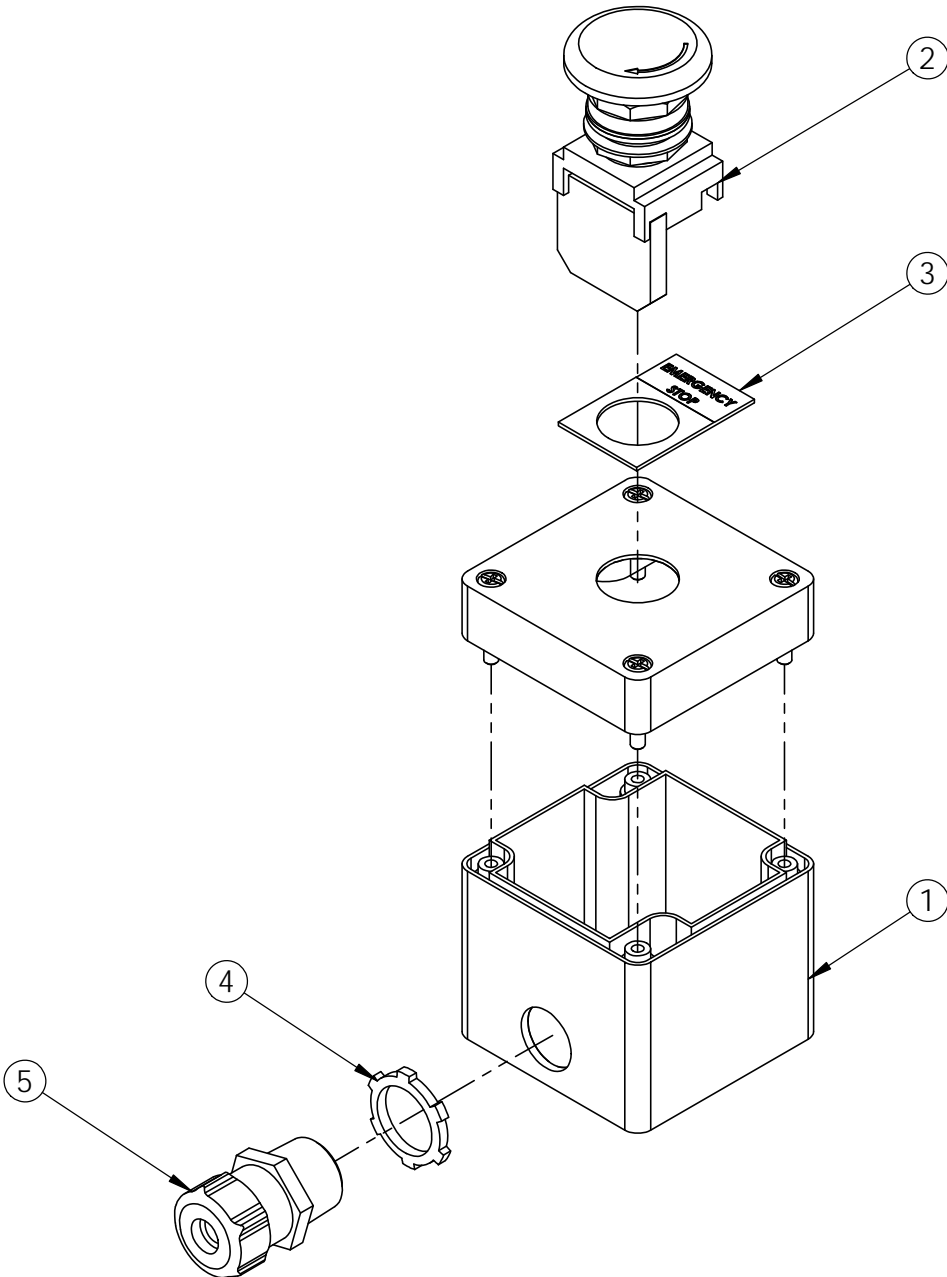

USM8075

ITEM	PART #	DESCRIPTION	QTY.
1	UPM7293	ENCLOS PB 1 HOLE NON METAL	1
2	UPM2211	BUTTON MUSHROOM 22mm 1 N.C.	1
3	UPM2209	LEGEND PLATE "E-STOP"	1
4	UPM0341	LOCKNUT 1/2"(FOR STRAIN RELF)	1
5	UPM0197	STR.RELF METL.LIQDTGHT 1/4-3/8	1

Electrical Drawing

